

TOPJOB® S

Through/Ground Conductor/Ex and Double-Potential Terminal Blocks

1 (1.5) mm², 2000 Series

0.14 ... 1 (1.5) mm ² ① AWG 24 ... 16 800 V/8 kV/3 ② I _N 13.5 A (18 A) Terminal block width 3.5 mm / 0.138 in. 9 ... 11 mm / 0.39 in. ③	0.14 ... 1 (1.5) mm ² ① AWG 24 ... 16 800 V/8 kV/3 ② I _N 13.5 A (18 A) Terminal block width 3.5 mm / 0.138 in. 9 ... 11 mm / 0.39 in. ③	0.14 ... 1 (1.5) mm ² ① AWG 24 ... 16 800 V/8 kV/3 ② I _N 13.5 A (18 A) Terminal block width 3.5 mm / 0.138 in. 9 ... 11 mm / 0.39 in. ③
--	--	--

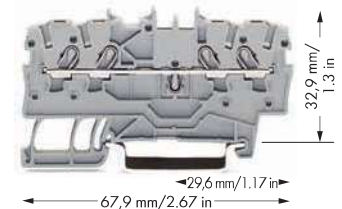
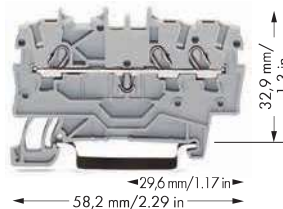
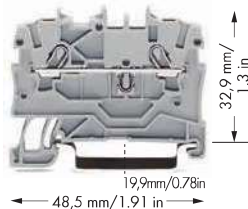

Item No.	Pack. Unit	Item No.	Pack. Unit	Item No.	Pack. Unit
2-conductor through terminal block		3-conductor through terminal block		4-conductor through terminal block	
gray ⑤	2000-1201 ⑤ 100	gray ⑤	2000-1301 ⑤ 100	gray ⑤	2000-1401 ⑤ 100
blue ⑤	2000-1204 ④ ⑤ 100	blue ⑤	2000-1304 ④ ⑤ 100	blue ⑤	2000-1404 ④ ⑤ 100
orange ⑤	2000-1202 ⑤ 100	orange ⑤	2000-1302 ⑤ 100	orange ⑤	2000-1402 ⑤ 100
red ⑤	2000-1203 ⑤ 100	red ⑤	2000-1303 ⑤ 100	red ⑤	2000-1403 ⑤ 100
black ⑤	2000-1205 ⑤ 100	black ⑤	2000-1305 ⑤ 100	black ⑤	2000-1405 ⑤ 100
yellow ⑤	2000-1206 ⑤ 100	yellow ⑤	2000-1306 ⑤ 100	yellow ⑤	2000-1406 ⑤ 100
2-conductor ground terminal block		3-conductor ground terminal block		4-conductor ground terminal block	
green-yellow ⑤	2000-1207 ⑤ 100	green-yellow ⑤	2000-1307 ⑤ 100	green-yellow ⑤	2000-1407 ⑤ 100
Item-Specific Accessories		Item-Specific Accessories		Item-Specific Accessories	
End and intermediate plate, 0.7 mm thick		End and intermediate plate, 0.7 mm thick		End and intermediate plate, 0.7 mm thick	
orange	2000-1292 100 (4x25)	orange	2000-1392 100 (4x25)	orange	2000-1492 100 (4x25)
gray	2000-1291 100 (4x25)	gray	2000-1391 100 (4x25)	gray	2000-1491 100 (4x25)
Ex e/Ex i separator, orange, 3 mm thick		Ex e/Ex i separator, orange, 3 mm thick		Ex e/Ex i separator, orange, 3 mm thick	
90 mm	209-190 50 (2x25)	120 mm	209-191 50 (2x25)	120 mm	209-191 50 (2x25)

2000 Series Accessories

Appropriate marking systems: WMB/Marking strips

Push-in type jumper bar, insulated, I _N 14 A, light gray 2-way 2000-402 200 (8x25) 3-way 2000-403 200 (8x25) 4-way 2000-404 200 (8x25) 5-way 2000-405 100 (4x25) 6-way 2000-406 100 (4x25) 7-way 2000-407 100 (4x25) 8-way 2000-408 100 (4x25) 9-way 2000-409 100 (4x25) 10-way 2000-410 100 (4x25)	Protective warning marker, with high-voltage symbol, black, for 5 terminal blocks yellow 2000-115 100 (4x25) Delta jumper, insulated, I _N = I _N terminal block, light gray 1-2 3-4 5-6 2000-406/020-000 100 (4x25) Star point jumper, insulated, I _N = I _N terminal block, light gray 1-3-5 2000-405/011-000 100 (4x25)	Banana plug, for socket 4 mm Ø, color mixed 215-111 50 Testing tap, for max. 2.5 mm ² gray 2009-182 100 (4x25) Test plug, with 500 mm cable, 2 mm Ø red 210-136 50 Test plug, with 500 mm cable, 2.3 mm Ø yellow 210-137 50
Push-in type jumper bar, insulated, I _N 14 A, light gray from 1 to 3 2000-433 200 (8x25) from 1 to 4 2000-434 200 (8x25) from 1 to 5 2000-435 100 (4x25) from 1 to 6 2000-436 100 (4x25) from 1 to 7 2000-437 100 (4x25) from 1 to 8 2000-438 100 (4x25) from 1 to 9 2000-439 100 (4x25) from 1 to 10 2000-440 100 (4x25)	Push-in type wire jumper, insulated, I _N 16 A, wire size 1.5 mm ² L = 60 mm 2009-402 100 (10x10) L = 110 mm 2009-404 100 (10x10) L = 250 mm 2009-406 100 (10x10) Test plug adapter, for 4 mm Ø test plug gray 2009-174 100 (4x25)	Marking strip, plain, 11 mm wide, 50 m roll white 2009-110 1 WMB Multi marking system, 10 strips with 10 markers per card, for 3.5 mm terminal block width plain 793-3501 5

0.14 ... 1 (1.5) mm² ① | AWG 24 ... 16
 800 V/8 kV/3 ②
 I_N 13.5 A (18 A)
 Terminal block width 3.5 mm / 0.138 in.
 ③ 9 ... 11 mm / 0.39 in. ③

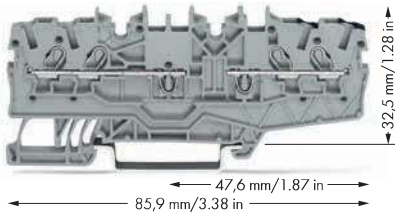

- ① Conductor sizes: 0.14 mm² ... 1.5 mm² "s + f-st"; Push-in conductor sizes: 0.5 mm² ... 1.5 mm² "s" and 0.5 mm² ... 0.75 mm² "insulated ferrule, 10 mm"
- ② 800 V = rated voltage
8 kV = rated surge voltage
3 = pollution degree
(see Full Line Catalog, Volume 1, Section 14)
- ③ Strip length, see packaging or instructions.
- ④ Suitable for Ex i applications
- ⑤ Suitable for Ex e II applications
550 V, 13 A
Jumper 12 A
(see Full Line Catalog, Volume 1, Section 14)
- ⑥ See application notes for:
Ex e/Ex i separator plate, page 27
Colored push-in type jumper bars, page 163
Star point jumper, page 165
Delta jumper, page 165
Push-in type wire jumper, page 164

Item No.	Pack. Unit
Double-potential terminal block, both potentials can be commoned	
○ gray 2000-2141	50

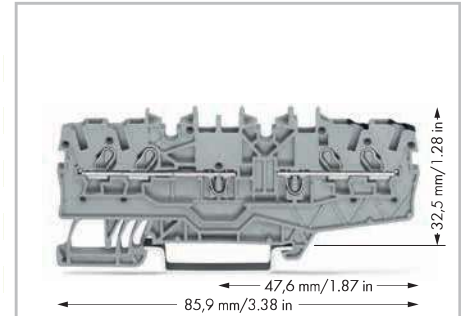
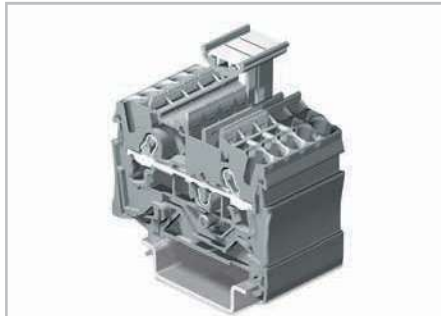

TOPJOB® S group marker carrier
 equipped with WMB Multi marking system.
 Suitable for all 2000 ... 2016 Series TOPJOB® S
 rail-mounted terminal blocks
 Do not use on an end plate!

Double-potential terminal blocks are space savers. Two independent feedthrough circuits are placed in one insulated housing on one level in just 3.5 mm. This achieves a width of just 1.75 mm/0.069 in. versus standard through terminal blocks. Input and output contacts of one circuit are placed on the same side of the terminal block. Both circuits can be individually marked according to input and output.

Item-Specific Accessories

End and intermediate plate, 0.7 mm thick		
orange	2000-2196	100 (4x25)
gray	2000-2195	100 (4x25)



Standard and quick marking options:
 Three marker slots are available for both individual markers and marking strips.

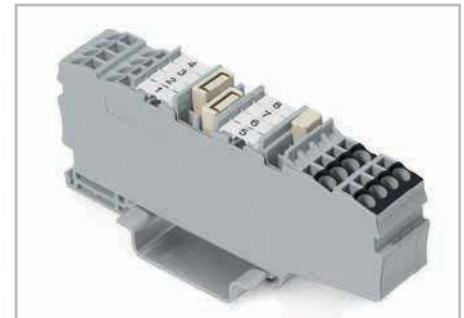



Standard and fast marking options:
 Four marker slots (double-potential terminal blocks) are available for both individual markers and marking strips.

TOPJOB® S

Through/Ground Conductor/Shield and Ex Terminal Blocks 1.5 (2.5) mm²

2001 Series

0.25 ... 1.5 (2.5) mm ² ① 800 V/8 kV/3 ② I _N 18 A (24 A)	AWG 22 ... 14 600 V, 15 A ③ 600 V, 15 A ④	0.25 ... 1.5 (2.5) mm ² ① 800 V/8 kV/3 ② I _N 18 A (24 A)	AWG 22 ... 14 600 V, 15 A ③ 600 V, 15 A ④	0.25 ... 1.5 (2.5) mm ² ① 800 V/8 kV/3 ② I _N 18 A (24 A)	AWG 22 ... 14 600 V, 15 A ③ 600 V, 15 A ④
Terminal block width 4.2 mm / 0.165 in.  9 ... 11 mm / 0.39 in. ⑤		Terminal block width 4.2 mm / 0.165 in.  9 ... 11 mm / 0.39 in. ⑤		Terminal block width 4.2 mm / 0.165 in.  9 ... 11 mm / 0.39 in. ⑤	

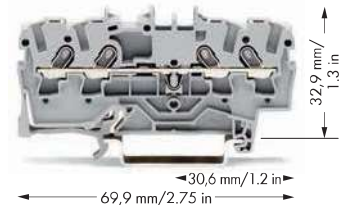
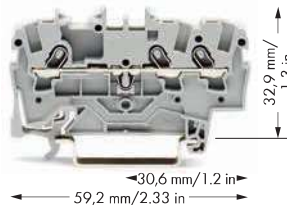
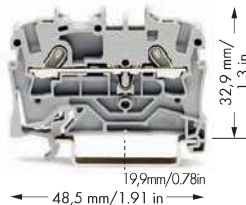

Item No.	Pack. Unit	Item No.	Pack. Unit	Item No.	Pack. Unit
2-conductor through terminal block		3-conductor through terminal block		4-conductor through terminal block	
gray ⑤	2001-1201 ⑤ 100	gray ⑤	2001-1301 ⑤ 100	gray ⑤	2001-1401 ⑤ 100
blue ⑤	2001-1204 ④ ⑤ 100	blue ⑤	2001-1304 ④ ⑤ 100	blue ⑤	2001-1404 ④ ⑤ 100
orange ⑤	2001-1202 ⑤ 100	orange ⑤	2001-1302 ⑤ 100	orange ⑤	2001-1402 ⑤ 100
red ⑤	2001-1203 ⑤ 100	red ⑤	2001-1303 ⑤ 100	red ⑤	2001-1403 ⑤ 100
black ⑤	2001-1205 ⑤ 100	black ⑤	2001-1305 ⑤ 100	black ⑤	2001-1405 ⑤ 100
yellow ⑤	2001-1206 ⑤ 100	yellow ⑤	2001-1306 ⑤ 100	yellow ⑤	2001-1406 ⑤ 100
2-conductor ground terminal block		3-conductor ground terminal block		4-conductor ground terminal block	
green-yellow ⑤	2001-1207 ⑤ 100	green-yellow ⑤	2001-1307 ⑤ 100	green-yellow ⑤	2001-1407 ⑤ 100
Other terminal blocks with the same profile:		Other terminal blocks with the same profile:		Other terminal blocks with the same profile:	
Diode	2001-1211/1000-411 Page 92	Diode	2001-1311/1000-411 Page 92	Diode	2001-1411/1000-411 Page 92
		LED	2001-1321/1000-434 Page 92	LED	2001-1421/1000-434 Page 92
				Double-potential	2001-1441 Page 21
Item-Specific Accessories		Item-Specific Accessories		Item-Specific Accessories	
End and intermediate plate, 0.8 mm thick		End and intermediate plate, 0.8 mm thick		End and intermediate plate, 0.8 mm thick	
orange	2002-1292 100 (4x25)	orange	2002-1392 100 (4x25)	orange	2002-1492 100 (4x25)
gray	2002-1291 100 (4x25)	gray	2002-1391 100 (4x25)	gray	2002-1491 100 (4x25)
Separator, oversized, 2 mm thick		Separator, oversized, 2 mm thick		Separator, oversized, 2 mm thick	
orange	2002-1294 100 (4x25)	orange	2002-1394 100 (4x25)	orange	2002-1494 100 (4x25)
gray	2002-1293 100 (4x25)	gray	2002-1393 100 (4x25)	gray	2002-1493 100 (4x25)
Ex e/Ex i separator, orange, 3 mm thick		Ex e/Ex i separator, orange, 3 mm thick		Ex e/Ex i separator, orange, 3 mm thick	
90 mm	209-190 50 (2x25)	120 mm	209-191 50 (2x25)	120 mm	209-191 50 (2x25)

2001 Series Accessories

Appropriate marking systems: WMB/WMB Inline/Marking strips

Insulation stop,	Push-in type jumper bar, insulated,	Push-in type jumper bar, insulated,
5 pcs/strip, 0.25 ... 0.5 mm ² light gray	I _N 18 A, light gray	I _N 18 A, light gray
2001-171 200 (8x25)	2-way 2001-402 200 (8x25)	from 1 to 3 2001-433 200 (8x25)
Step-down jumper, insulated,	3-way 2001-403 200 (8x25)	from 1 to 4 2001-434 200 (8x25)
I _N 32 A	4-way 2001-404 200 (8x25)	from 1 to 5 2001-435 100 (4x25)
light gray	5-way 2001-405 100 (4x25)	from 1 to 6 2001-436 100 (4x25)
2006-499 50 (2x25)	6-way 2001-406 100 (4x25)	from 1 to 7 2001-437 100 (4x25)
Protective warning marker,	7-way 2001-407 100 (4x25)	from 1 to 8 2001-438 100 (4x25)
with high-voltage symbol, black,	8-way 2001-408 100 (4x25)	from 1 to 9 2001-439 100 (4x25)
for 5 terminal blocks	9-way 2001-409 100 (4x25)	from 1 to 10 2001-440 100 (4x25)
yellow	10-way 2001-410 100 (4x25)	
2001-115 100 (4x25)		

Approvals see www.wago.com

Double-Potential Terminal Blocks 1.5 (2.5) mm² 2001 Series

PUSH-IN CAGE CLAMP®

- 1 Conductor sizes: 0.25 mm² ... 2.5 mm² "s + fst";
Push-in conductor sizes: 0.5 mm² ... 2.5 mm² "s"
and 0.75 mm² ... 1.5 mm²
"insulated ferrule, 12 mm"
- 2 800 V = rated voltage
8 kV = rated surge voltage
3 = pollution degree
(see Full Line Catalog, Volume 1, Section 14)
- 3 Strip length, see packaging or instructions.
- 4 Suitable for Ex i applications
- 5 Suitable for Ex e II applications
550 V, 17 A
Jumper 16 A
(see Full Line Catalog, Volume 1, Section 14)
- 6 See application notes for:
Ex e/Ex i separator plate, page 27
Step-down jumper, page 28
Star point jumper, page 165
Delta jumper, page 165
Push-in type wire jumper, page 164
TOPJOB® S connector, page 158

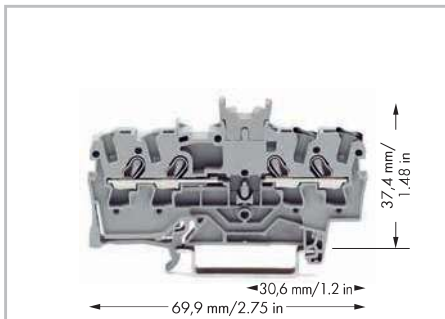

Double-potential terminal block with double marker slot centered on terminal block
gray 2001-1441
Packing unit: 100 pcs

















Notice: This double-potential terminal block cannot be commoned with push-in type jumper bars!

Double-potential terminal blocks are space savers. Two independent feedthrough circuits are placed in one insulated housing on one level in just 4.2 mm. This achieves a width of just 2.1 mm/0.083 in. versus standard through terminal blocks. Input and output contacts of one circuit are placed on the same side of the terminal block. Both circuits can be individually marked according to input and output.

For technical data and accessories, see www.wagocatalog.com

2001 Series Accessories



Appropriate marking systems: WMB/WMB Inline/Marking strips

Delta jumper, insulated,  I _N = I _N terminal block, light gray 1-2 3-4 5-6 2001-406/020-000 100 (4x25)	WMB Inline, plain,  stretchable 4 ... 4.2 mm, 2,000 WMB markers, 4 mm, on roll white 2009-114 1
Star point jumper, insulated,  I _N = I _N terminal block, light gray 1-3-5 2001-405/011-000 100 (4x25)	WMB Multi marking system,  10 strips with 10 markers per card, stretchable 4 ... 4.2 mm plain 793-4501 5
Push-in type wire jumper,  insulated, I _N 16 A, wire size 1.5 mm ² L = 60 mm 2009-412 100 (10x10) L = 110 mm 2009-414 100 (10x10) L = 250 mm 2009-416 100 (10x10)	WMB Multi marking system, plain,  10 strips with 10 markers per card, stretchable 4 ... 4.2 mm yellow 793-4501/000-002 red 793-4501/000-005 blue 793-4501/000-006 gray 793-4501/000-007 orange 793-4501/000-012 light green 793-4501/000-017 green 793-4501/000-023 violet 793-4501/000-024 5
Modular TOPJOB® S connector,  can be snapped together, for jumper contact slot gray 2001-511 100 (4x25)	Marking strip, plain,  11 mm wide, 50 m roll white 2009-110 1
Spacer module, can be snapped together,  e.g., for bridging commoned terminal blocks gray 2001-549 100 (4x25)	Screwless end stop,  for DIN 35 rail, 6 mm wide gray 249-116 100 (4x25)
End plate,  for modular TOPJOB® S connectors, 1.5 mm thick gray 2002-541 100 (4x25)	Screwless end stop,  for DIN 35 rail, 10 mm wide gray 249-117 50 (2x25)
Test plug adapter,  for 4 mm Ø test plug gray 2009-174 100 (4x25)	
Banana plug,  for socket 4 mm Ø, color mixed 215-111 50	
Testing tap,  for max. 2.5 mm ² gray 2009-182 100 (4x25)	
Test plug,  with 500 mm cable, 2 mm Ø red 210-136 50	
Test plug,  with 500 mm cable, 2.3 mm Ø yellow 210-137 50	

TOPJOB® S

Through/Ground Conductor/Shield and Ex Terminal Blocks 2.5 (4) mm²

2002 Series

0.25 ... 2.5 (4) mm ² ① 800 V/8 kV/3 ② I _N 24 A (32 A)	AWG 22 ... 12 600 V, 20 A ③ 600 V, 20 A ④	0.25 ... 2.5 (4) mm ² ① 800 V/8 kV/3 ② I _N 24 A (32 A)	AWG 22 ... 12 600 V, 20 A ③ 600 V, 20 A ④	0.25 ... 2.5 (4) mm ² ① 800 V/8 kV/3 ② I _N 24 A (32 A)	AWG 22 ... 12 600 V, 20 A ③ 600 V, 20 A ④
Terminal block width 5.2 mm / 0.205 in.  10 ... 12 mm / 0.43 in. ③		Terminal block width 5.2 mm / 0.205 in.  10 ... 12 mm / 0.43 in. ③		Terminal block width 5.2 mm / 0.205 in.  10 ... 12 mm / 0.43 in. ③	

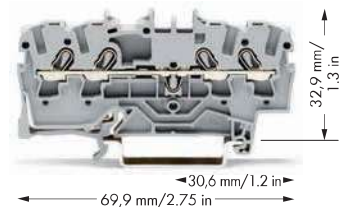
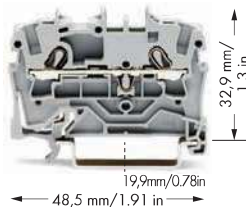

Item No.	Pack. Unit	Item No.	Pack. Unit	Item No.	Pack. Unit
2-conductor through terminal block		3-conductor through terminal block		4-conductor through terminal block	
gray ⑤ 2002-1201 ⑤ 100		gray ⑤ 2002-1301 ⑤ 100		gray ⑤ 2002-1401 ⑤ 100	
blue ⑤ 2002-1204 ④ ⑤ 100		blue ⑤ 2002-1304 ④ ⑤ 100		blue ⑤ 2002-1404 ④ ⑤ 100	
orange ⑤ 2002-1202 ⑤ 100		orange ⑤ 2002-1302 ⑤ 100		orange ⑤ 2002-1402 ⑤ 100	
red ⑤ 2002-1203 ⑤ 100		red ⑤ 2002-1303 ⑤ 100		red ⑤ 2002-1403 ⑤ 100	
black ⑤ 2002-1205 ⑤ 100		black ⑤ 2002-1305 ⑤ 100		black ⑤ 2002-1405 ⑤ 100	
yellow ⑤ 2002-1206 ⑤ 100		yellow ⑤ 2002-1306 ⑤ 100		yellow ⑤ 2002-1406 ⑤ 100	
2-conductor ground terminal block		3-conductor ground terminal block		4-conductor ground terminal block	
green-yellow ⑤ 2002-1207 ⑤ 100		green-yellow ⑤ 2002-1307 ⑤ 100		green-yellow ⑤ 2002-1407 ⑤ 100	
2-conductor shield terminal block		3-conductor shield terminal block		4-conductor shield terminal block	
white 2002-1208 100		white 2002-1308 100		white 2002-1408 100	
Other terminal blocks with the same profile:		Other terminal blocks with the same profile:		Other terminal blocks with the same profile:	
Diode 2002-1211/1000-411 Page 94		Diode 2002-1311/1000-411 Page 94		Diode 2002-1411/1000-411 Page 94	
		LED 2002-1321/1000-434 Page 94		LED 2002-1421/1000-434 Page 94	
				Double-potential 2002-1441 Page 23	
Item-Specific Accessories		Item-Specific Accessories		Item-Specific Accessories	
End and intermediate plate, 0.8 mm thick		End and intermediate plate, 0.8 mm thick		End and intermediate plate, 0.8 mm thick	
orange 2002-1292 100 (4x25)		orange 2002-1392 100 (4x25)		orange 2002-1492 100 (4x25)	
gray 2002-1291 100 (4x25)		gray 2002-1391 100 (4x25)		gray 2002-1491 100 (4x25)	
Separator, oversized, 2 mm thick		Separator, oversized, 2 mm thick		Separator, oversized, 2 mm thick	
orange 2002-1294 100 (4x25)		orange 2002-1394 100 (4x25)		orange 2002-1494 100 (4x25)	
gray 2002-1293 100 (4x25)		gray 2002-1393 100 (4x25)		gray 2002-1493 100 (4x25)	
Ex e/Ex i separator, orange, 3 mm thick		Ex e/Ex i separator, orange, 3 mm thick		Ex e/Ex i separator, orange, 3 mm thick	
90 mm 209-190 50 (2x25)		120 mm 209-191 50 (2x25)		120 mm 209-191 50 (2x25)	

2002 Series Accessories

Appropriate marking systems: WMB/WMB Inline/Marking strips

Insulation stop,	Push-in type jumper bar, insulated,	Push-in type jumper bar, insulated,
5 pcs/strip, 0.25 ... 0.5 mm ² light gray 2002-171 200 (8x25)	⑥ I _N 25 A, light gray 2-way 2002-402 200 (8x25) 3-way 2002-403 200 (8x25) 4-way 2002-404 200 (8x25) 5-way 2002-405 100 (4x25) 6-way 2002-406 100 (4x25) 7-way 2002-407 100 (4x25) 8-way 2002-408 100 (4x25) 9-way 2002-409 100 (4x25) 10-way 2002-410 100 (4x25)	I _N 25 A, light gray from 1 to 3 2002-433 200 (8x25) from 1 to 4 2002-434 200 (8x25) from 1 to 5 2002-435 100 (4x25) from 1 to 6 2002-436 100 (4x25) from 1 to 7 2002-437 100 (4x25) from 1 to 8 2002-438 100 (4x25) from 1 to 9 2002-439 100 (4x25) from 1 to 10 2002-440 100 (4x25)
Insulation stop, 5 pcs/strip, 0.75 ... 1 mm ² dark gray 2002-172 200 (8x25)		
Protective warning marker, with high-voltage symbol, black, for 5 terminal blocks yellow 2002-115 100 (4x25)		

Approvals see www.wago.com

Double-Potential Terminal Blocks 2.5 (4) mm² 2002 Series Accessories for Rail-Mounted Terminal Blocks

PUSH-IN CAGE CLAMP®

- ① Conductor sizes: 0.25 mm² ... 4 mm² "s + fst";
Push-in conductor sizes: 0.75 mm² ... 4 mm² "s"
and 0.75 mm² ... 2.5 mm²
"insulated ferrule, 1.2 mm"
- ② 800 V = rated voltage
8 kV = rated surge voltage
3 = pollution degree
(see Full Line Catalog, Volume 1, Section 14)
- ③ Strip length, see packaging or instructions.
- ④ Suitable for Ex i applications
- ⑤ Suitable for Ex e II applications
550 V, 22 A
Jumper 20 A
(see Full Line Catalog, Volume 1, Section 14)
- ⑥ See application notes for:
Ex e/Ex i separator plate, page 27
Colored push-in type jumper bars, page 163
Staggered jumper, page 166
Delta jumper, page 165
Star point jumper, page 165
Step-down jumper, page 28
Adjacent jumper for continuous commoning,
page 163
Push-in type wire jumper, page 164
TOPJOB® S connector, page 158
TOPJOB® S L-type test plug module, page 162
Marker carrier, page 179



Double-potential terminal block with double marker slot centered on terminal block
gray 2002-1441
Packing unit: 100 pcs

















Notice: This double-potential terminal block cannot be commoned with push-in type jumper bars!

Double-potential terminal blocks are space savers. Two independent feedthrough circuits are placed in one insulated housing on one level in just 5.2 mm. This achieves a width of just 2.6 mm/0.103 in. versus standard through terminal blocks. Input and output contacts of one circuit are placed on the same side of the terminal block. Both circuits can be individually marked according to input and output.

For technical data and accessories, see www.wagocatalog.com

2002 Series Accessories

Appropriate marking systems: WMB/WMB Inline/Marking strips

Staggered jumper,  insulated, I_N 25 A, light gray 2-way 2002-472 100 (4x25) 3-way 2002-473 100 (4x25) 4-way 2002-474 100 (4x25) 5-way 2002-475 50 (2x25) 6-way 2002-476 50 (2x25) 7-way 2002-477 50 (2x25) 8-way 2002-478 50 (2x25) 9-way 2002-479 50 (2x25) 10-way 2002-480 50 (2x25) 11-way 2002-481 50 (2x25) 12-way 2002-482 50 (2x25)	Push-in type wire jumper,  insulated, I_N 18 A, wire size 1.5 mm ² L = 60 mm 2009-412 100 (10x10) L = 110 mm 2009-414 100 (10x10) L = 250 mm 2009-416 100 (10x10)
Customized staggered jumper,  insulated, I_N 25 A, light gray 1-3 2002-473/011-000 100 (4x25) 1-3-5 2002-475/011-000 1-3-5-7 2002-477/011-000 1-3-5-7-9 2002-479/011-000 1-3-5-7-9-11 2002-481/011-000 50 (2x25)	Modular TOPJOB® S connector,  can be snapped together, for jumper contact slot gray 2002-511 100 (4x25) Spacer module, can be snapped together, e.g., for bridging commoned terminal blocks gray 2002-549 100 (4x25)
Delta jumper, insulated,  $I_N = I_N$ terminal block, light gray 1-2 3-4 5-6 2002-406/020-000 100 (4x25)	End plate,  for modular TOPJOB® S connectors, 1.5 mm thick gray 2002-541 100 (4x25)
Star point jumper, insulated,  $I_N = I_N$ terminal block, light gray 1-3-5 2002-405/011-000 100 (4x25)	Test plug adapter,  for 4 mm Ø test plug gray 2009-174 100 (4x25)
Step-down jumper, insulated,  I_N 32 A light gray 2006-499 50 (2x25)	Testing tap,  for max. 2.5 mm ² gray 2009-182 100 (4x25)
Adjacent jumper for continuous commoning, insulated,  I_N 25 A, light gray 2-way 2002-400 100 (4x25)	TOPJOB® S L-test plug module,  can be snapped together gray 2002-611 100 (4x25)
WMB Inline, plain,  stretchable 5 ... 5.2 mm, 1,500 WMB markers, 5 mm, on roll white 2009-115 1	TOPJOB® S L-type spacer module, can be snapped together, e.g., for bridging commoned terminal blocks  gray 2002-649 100 (4x25)
	End plate, for modular TOPJOB® S test plugs,  1.5 mm thick gray 2002-641 100 (4x25)
	Marker carrier,  for jumper slots 2002 Series, 5 mm wide gray 2002-161 100 (4x25)
	WMB Multi marking system,  10 strips with 10 markers per card, stretchable 5 ... 5.2 mm plain 793-5501 5

TOPJOB® S

Through/Ground Conductor/Shield and Ex Terminal Blocks





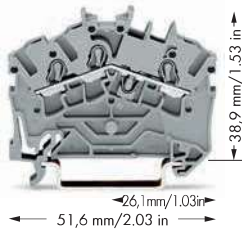

























2.5 (4) mm², 2002 Series

0.25 ... 2.5 (4) mm ² ①	AWG 22 ... 12
800 V/8 kV/3 ②	600 V, 20 A ④
I _N 24 A (32 A)	600 V, 20 A ⑤
Terminal block width 5.2 mm / 0.205 in.	
 10 ... 12 mm / 0.43 in. ③	



PUSH-IN CAGE CLAMP®

- ① Conductor sizes: 0.25 mm² ... 4 mm² "s + f-st";
Push-in conductor sizes: 0.75 mm² ... 4 mm² "s"
and 0.75 mm² ... 2.5 mm²
"insulated ferrule, 12 mm"
- ② 800 V = rated voltage
8 kV = rated surge voltage
3 = pollution degree
(see Full Line Catalog, Volume 1, Section 14)
- ③ Strip length, see packaging or instructions.
- ④ Suitable for Ex i applications
- ⑤ Suitable for Ex e II applications
550 V, 22 A
Jumper 20 A
(see Full Line Catalog, Volume 1, Section 14)
- ⑥ See application notes for:
Ex e/Ex i separator plate, page 27
Colored push-in type jumper bars, page 163
Staggered jumper, page 166
Delta jumper, page 165
Star point jumper, page 165
Adjacent jumper for continuous commoning,
page 163
Push-in type wire jumper, page 164
TOPJOB® S connector, page 158
TOPJOB® S L-type test plug module, page 162
Marker carrier, page 179

Item No.	Pack. Unit	2002 Series Accessories	
		Appropriate marking systems: WMB/WMB Inline/Marking strips	
3-conductor through terminal block			
 gray ⑤	2002-6301 ⑤	100	
 blue ⑤	2002-6304 ④ ⑤	100	
 orange ⑤	2002-6302 ⑤	100	
 red ⑤	2002-6303 ⑤	100	
 black ⑤	2002-6305 ⑤	100	
 yellow ⑤	2002-6306 ⑤	100	
3-conductor ground terminal block			
 green-yellow ⑤	2002-6307 ⑤	100	
3-conductor shield terminal block			
 white	2002-6308	100	
2002 Series Accessories			
End and intermediate plate, 0.8 mm thick			
 orange	2002-6392	100 (4x25)	
 gray	2002-6391	100 (4x25)	
Ex e/Ex i separator, orange, 3 mm thick			
 120 mm	209-191	50 (2x25)	
Insulation stop, 5 pcs/strip, 0.25 ... 0.5 mm²			
 light gray	2002-171	200 (8x25)	
Insulation stop, 5 pcs/strip, 0.75 ... 1 mm²			
 dark gray	2002-172	200 (8x25)	
Push-in type jumper bar, insulated, I_N 25 A, light gray			
 2-way	2002-402	200 (8x25)	
3-way	2002-403	200 (8x25)	
4-way	2002-404	200 (8x25)	
5-way	2002-405	100 (4x25)	
6-way	2002-406	100 (4x25)	
7-way	2002-407	100 (4x25)	
8-way	2002-408	100 (4x25)	
9-way	2002-409	100 (4x25)	
10-way	2002-410	100 (4x25)	
Adjacent jumper for continuous commoning, insulated, I_N 25 A, light gray			
 2-way	2002-400	100 (4x25)	
Push-in type jumper bar, insulated, I_N 25 A, light gray			
 from 1 to 3	2002-433	200 (8x25)	
from 1 to 4	2002-434	200 (8x25)	
from 1 to 5	2002-435	100 (4x25)	
from 1 to 6	2002-436	100 (4x25)	
from 1 to 7	2002-437	100 (4x25)	
from 1 to 8	2002-438	100 (4x25)	
from 1 to 9	2002-439	100 (4x25)	
from 1 to 10	2002-440	100 (4x25)	
Delta jumper, insulated, I_N = I_N terminal block, light gray			
 1-2 3-4 5-6	2002-406/020-000	100 (4x25)	
Star point jumper, insulated, I_N = I_N terminal block, light gray			
 1-3-5	2002-405/011-000	100 (4x25)	
Staggered jumper, insulated, I_N 25 A, light gray			
 2-way	2002-472	100 (4x25)	
3-way	2002-473	100 (4x25)	
4-way	2002-474	100 (4x25)	
5-way	2002-475	50 (2x25)	
6-way	2002-476	50 (2x25)	
7-way	2002-477	50 (2x25)	
8-way	2002-478	50 (2x25)	
9-way	2002-479	50 (2x25)	
10-way	2002-480	50 (2x25)	
11-way	2002-481	50 (2x25)	
12-way	2002-482	50 (2x25)	
Customized staggered jumper, insulated, I_N 25 A, light gray			
 1-3	2002-473/011-000	100 (4x25)	
1-3-5	2002-475/011-000	100 (4x25)	
1-3-5-7	2002-477/011-000	100 (4x25)	
1-3-5-7-9	2002-479/011-000	100 (4x25)	
1-3-5-7-9-11	2002-481/011-000	50 (2x25)	
Push-in type wire jumper, insulated, I_N 18 A, wire size 1.5 mm²			
 L = 60 mm	2009-412	100 (10x10)	
L = 110 mm	2009-414	100 (10x10)	
L = 250 mm	2009-416	100 (10x10)	
Protective warning marker, with high-voltage symbol, black, for 5 terminal blocks			
 yellow	2002-115	100 (4x25)	
Modular TOPJOB® S connector, can be snapped together, for jumper contact slot			
 gray	2002-511	100 (4x25)	
TOPJOB® S L-test plug module, can be snapped together			
 gray	2002-611	100 (4x25)	
Test plug adapter, for 4 mm Ø test plug			
 gray	2009-174	100 (4x25)	
Testing tap, for max. 2.5 mm²			
 gray	2009-182	100 (4x25)	
WMB Inline, plain, stretchable 5 ... 5.2 mm, 1,500 WMB markers, 5 mm, on roll			
 white	2009-115	1	
WMB Multi marking system, 10 strips with 10 markers per card, stretchable 5 ... 5.2 mm			
 plain	793-5501	5	
Marking strip, plain, 11 mm wide, 50 m roll			
 white	2009-110	1	
TOPJOB® S group marker carrier, snap-on type for jumper slot, 5 mm wide			
 gray	2009-191	50 (2x25)	
Marker carrier, for jumper slots 2002 Series, 5 mm wide			
 gray	2002-161	100 (4x25)	

TOPJOB® S

Through/Ground Conductor and Ex Terminal Blocks

2.5 (4) mm², 2002 Series

PUSH-IN CAGE CLAMP®

0.25 ... 2.5 (4) mm² ① AWG 22 ... 12
 800 V/8 kV/3 ② 600 V, 20 A ④
 I_N 24 A (32 A) 600 V, 20 A ⑤

Terminal block width 5.2 mm / 0.205 in.
 ③ 10 ... 12 mm / 0.43 in.

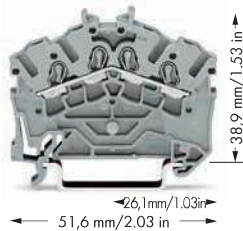

- ① Conductor sizes: 0.25 mm² ... 4 mm² "s + f-st";
 Push-in conductor sizes: 0.75 mm² ... 4 mm² "s"
 and 0.75 mm² ... 2.5 mm²
 "insulated ferrule, 12 mm"
- ② 800 V = rated voltage
 8 kV = rated surge voltage
 3 = pollution degree
 (see Full Line Catalog, Volume 1, Section 14)
- ③ Strip length, see packaging or instructions.
- ④ Suitable for Ex i applications
- ⑤ Suitable for Ex e II applications
 550 V, 22 A
 Jumper 20 A
 (see Full Line Catalog, Volume 1, Section 14)
- ⑥ See application notes for:
 Ex e/Ex i separator plate, page 27

Item No.	Pack. Unit
4-conductor through terminal block	
gray ⑤ 2002-6401 ⑤	100
blue ⑤ 2002-6404 ④ ⑤	100
orange ⑤ 2002-6402 ⑤	100
red ⑤ 2002-6403 ⑤	100
black ⑤ 2002-6405 ⑤	100
yellow ⑤ 2002-6406 ⑤	100
4-conductor ground terminal block	
green-yellow ⑤ 2002-6407 ⑤	100
Notice: These terminal blocks cannot be commoned with push-in type jumper bars.	

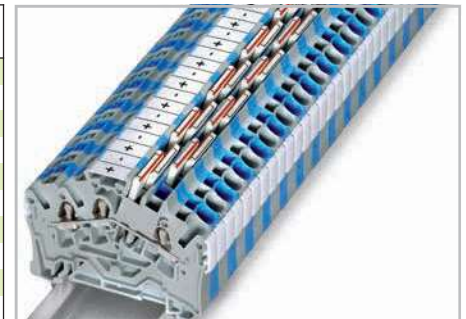

3- and 4-conductor terminal blocks of angled type
 The TOPJOB® S rail-mounted terminal blocks have a 35-degree conductor entry angle permitting a very small bend radius and an extremely short wiring distance to the cable duct. For applications in switchgear and control cabinets using the LSC wiring system from Lütze, e.g., these terminal blocks are a space- and cost-saving solution. This allows the cable duct to be placed very close to the terminal blocks, keeping its height relatively low.

2002 Series Accessories

Appropriate marking systems: WMB/WMB Inline/Marking strips

End and intermediate plate, 0.8 mm thick	WMB Multi marking system,
orange 2002-6392 100 (4x25)	10 strips with 10 markers per card, stretchable 5 ... 5.2 mm
gray 2002-6391 100 (4x25)	plain 793-5501 5
Ex e/Ex i separator, orange,	WMB Multi marking system, plain,
⑥ 3 mm thick	10 strips with 10 markers per card, stretchable 5 ... 5.2 mm
120 mm 209-191 50 (2x25)	yellow 793-5501/000-002
Insulation stop,	red 793-5501/000-005
5 pcs/strip, 0.25 ... 0.5 mm ²	blue 793-5501/000-006
light gray 2002-171 200 (8x25)	gray 793-5501/000-007
Insulation stop,	orange 793-5501/000-012
5 pcs/strip, 0.75 ... 1 mm ²	light green 793-5501/000-017
dark gray 2002-172 200 (8x25)	green 793-5501/000-023
Protective warning marker,	violet 793-5501/000-024 5
with high-voltage symbol, black, for 5 terminal blocks	Screwless end stop,
yellow 2002-115 100 (4x25)	for DIN 35 rail, 6 mm wide
WMB Inline, plain,	gray 249-116 100 (4x25)
stretchable 5 ... 5.2 mm, 1,500 WMB markers, 5 mm, on roll	Screwless end stop,
white 2009-115 1	for DIN 35 rail, 10 mm wide
Marking strip, plain,	gray 249-117 50 (2x25)
11 mm wide, 50 m roll	
white 2009-110 1	

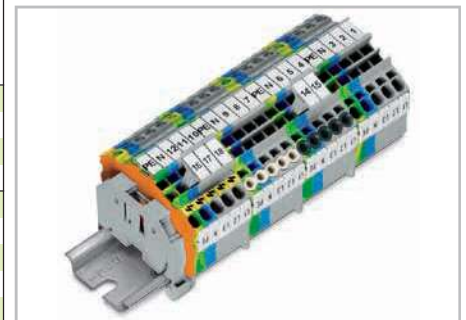

Product features:

- Push-in CAGE CLAMP® connection for all conductor types, with the additional benefit of stripped solid and stranded wires and fine-stranded ferruled wires being simply pushed in
- Vibration-proof, fast, maintenance-free terminations
- 3-conductor through and ground conductor terminal blocks equipped with a dual jumper slot
- 4-conductor terminal blocks permit potential multiplication – no additional jumpers or terminal blocks needed
- 3- and 4-conductor terminal blocks have the same dimensions

An end plate must be applied when changing from a 3-conductor terminal block to a 4-conductor terminal block and vice versa.

TOPJOB® S

Through/Ground Conductor/Shield and Ex Terminal Blocks 4 (6) mm²

2004 Series

0.5 ... 4 (6) mm ² ① 800 V/8 kV/3 ② I _N 32 A (41 A)	AWG 20 ... 10 600 V, 30 A ③ 600 V, 30 A ④	0.5 ... 4 (6) mm ² ① 800 V/8 kV/3 ② I _N 32 A (41 A)	AWG 20 ... 10 600 V, 30 A ③ 600 V, 30 A ④	0.5 ... 4 (6) mm ² ① 800 V/8 kV/3 ② I _N 32 A (41 A)	AWG 20 ... 10 600 V, 30 A ③ 600 V, 30 A ④
Terminal block width 6.2 mm / 0.244 in. □ 11 ... 13 mm / 0.47 in. ⑤		Terminal block width 6.2 mm / 0.244 in. □ 11 ... 13 mm / 0.47 in. ⑤		Terminal block width 6.2 mm / 0.244 in. □ 11 ... 13 mm / 0.47 in. ⑤	

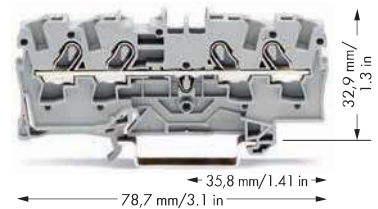
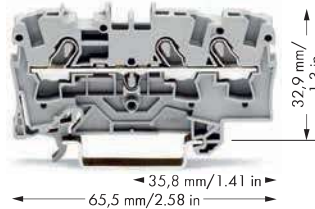
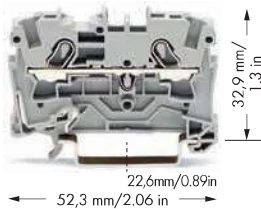

Item No.	Pack. Unit	Item No.	Pack. Unit	Item No.	Pack. Unit
2-conductor through terminal block		3-conductor through terminal block		4-conductor through terminal block	
gray ⑤ 2004-1201 ⑤ 50		gray ⑤ 2004-1301 ⑤ 50		gray ⑤ 2004-1401 ⑤ 50	
blue ⑤ 2004-1204 ④ ⑤ 50		blue ⑤ 2004-1304 ④ ⑤ 50		blue ⑤ 2004-1404 ④ ⑤ 50	
orange ⑤ 2004-1202 ⑤ 50		orange ⑤ 2004-1302 ⑤ 50		orange ⑤ 2004-1402 ⑤ 50	
red ⑤ 2004-1203 ⑤ 50		red ⑤ 2004-1303 ⑤ 50		red ⑤ 2004-1403 ⑤ 50	
black ⑤ 2004-1205 ⑤ 50		black ⑤ 2004-1305 ⑤ 50		black ⑤ 2004-1405 ⑤ 50	
yellow ⑤ 2004-1206 ⑤ 50		yellow ⑤ 2004-1306 ⑤ 50		yellow ⑤ 2004-1406 ⑤ 50	
2-conductor ground terminal block		3-conductor ground terminal block		4-conductor ground terminal block	
green-yellow ⑤ 2004-1207 ⑤ 50		green-yellow ⑤ 2004-1307 ⑤ 50		green-yellow ⑤ 2004-1407 ⑤ 50	
Other terminal blocks with the same profile:		Other terminal blocks with the same profile:		Other terminal blocks with the same profile:	
Diode 2004-1211/1000-401 Page 96		Diode 2004-1311/1000-401 Page 96		Diode 2004-1411/1000-401 Page 96	
Item-Specific Accessories		Item-Specific Accessories		Item-Specific Accessories	
End and intermediate plate, 1 mm thick		End and intermediate plate, 1 mm thick		End and intermediate plate, 1 mm thick	
orange 2004-1292 100 (4x25)		orange 2004-1392 100 (4x25)		orange 2004-1492 100 (4x25)	
gray 2004-1291 100 (4x25)		gray 2004-1391 100 (4x25)		gray 2004-1491 100 (4x25)	
Separator, oversized, 2 mm thick		Separator, oversized, 2 mm thick		Separator, oversized, 2 mm thick	
orange 2004-1294 100 (4x25)		orange 2004-1394 100 (4x25)		orange 2004-1494 100 (4x25)	
gray 2004-1293 100 (4x25)		gray 2004-1393 100 (4x25)		gray 2004-1493 100 (4x25)	
Ex e/Ex i separator, orange, 3 mm thick		Ex e/Ex i separator, orange, 3 mm thick		Ex e/Ex i separator, orange, 3 mm thick	
90 mm 209-190 50 (2x25)		120 mm 209-191 50 (2x25)		120 mm 209-191 50 (2x25)	

2004 Series Accessories

Appropriate marking systems: WMB/Marking strips

Insulation stop, 5 pcs/strip, 0.25 ... 0.5 mm ² light gray 2004-171 200 (8x25)	Insulation stop, 5 pcs/strip, 0.75 ... 1 mm ² dark gray 2004-172 200 (8x25)	Delta jumper, insulated, ⑥ I _N = I _N terminal block, light gray 1-2 3-4 5-6 2004-406/020-000 100 (4x25)
Push-in type jumper bar, insulated, I _N 32 A, light gray 2-way 2004-402 200 (8x25) 3-way 2004-403 200 (8x25) 4-way 2004-404 100 (4x25) 5-way 2004-405 100 (4x25) 6-way 2004-406 100 (4x25) 7-way 2004-407 100 (4x25) 8-way 2004-408 100 (4x25) 9-way 2004-409 100 (4x25) 10-way 2004-410 100 (4x25)	Push-in type jumper bar, insulated, I _N 32 A, light gray from 1 to 3 2004-433 200 (8x25) from 1 to 4 2004-434 200 (8x25) from 1 to 5 2004-435 100 (4x25) from 1 to 6 2004-436 100 (4x25) from 1 to 7 2004-437 100 (4x25) from 1 to 8 2004-438 100 (4x25) from 1 to 9 2004-439 100 (4x25) from 1 to 10 2004-440 100 (4x25)	Star point jumper, insulated, ⑥ I _N = I _N terminal block, light gray 1-3-5 2004-405/011-000 100 (4x25)
		Step-down jumper, insulated, ⑥ I _N 32 A light gray 2006-499 50 (2x25)
		Protective warning marker, with high-voltage symbol, black, for 5 terminal blocks yellow 2004-115 100 (4x25)

Terminal Blocks for Ex i or Ex e II Applications

PUSH-IN CAGE CLAMP®

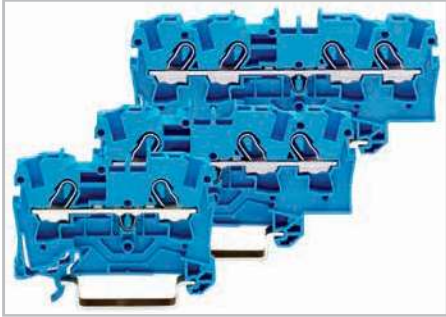

Through terminal blocks with blue insulated housing are suitable for Ex i applications.



All through and ground conductor terminal blocks are suitable for Ex e II applications.

- ❶ Conductor sizes: 0.5 mm² ... 6 mm² "s + f-st";
Push-in conductor sizes: 1 mm² ... 6 mm² "s"
and 0.75 mm² ... 4 mm²
"insulated ferrule, 12 mm"
- ❷ 800 V = rated voltage
8 kV = rated surge voltage
3 = pollution degree
(see Full Line Catalog, Volume 1, Section 14)
- ❸ Strip length, see packaging or instructions.
- ❹ Suitable for Ex i applications
- ❺ Suitable for Ex e II applications
550 V, 30 A
(see Full Line Catalog, Volume 1, Section 14)
- ❻ See application notes for:
Step-down jumper, page 28
Star point jumper, page 165
Delta jumper, page 165
TOPJOB® S connector, page 160

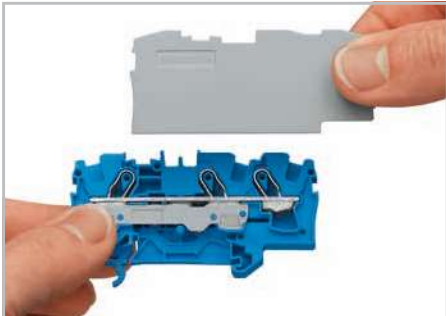

Separator for Ex e/Ex i applications
An end plate must be applied to the terminal block located directly behind an Ex e/Ex i separator plate.



Ex e II/Ex i terminal strip
Notice:
The movable feet of terminal blocks and separator plate must face the same direction.

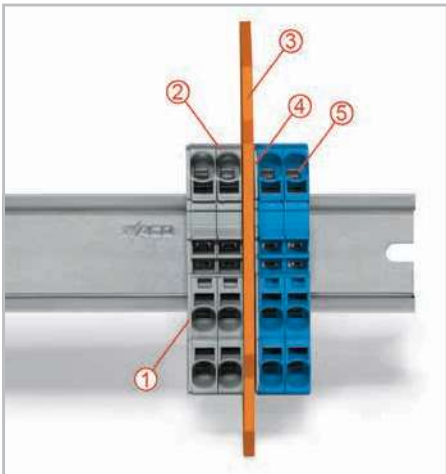

Separator located between Ex e II and Ex i terminal strip
 ❶ End plate
 ❷ Ex e II terminal blocks
 ❸ Ex e/Ex i separator plate
 ❹ End plate
 ❺ Ex i terminal blocks
 According to EN 50020, a minimum distance of 50 mm must be kept between live parts of Ex e and Ex i circuits. The use of Ex e/Ex i separators is a space-saving solution when Ex e and Ex i terminal blocks are mounted on a common carrier rail.

2004 Series Accessories

Modular TOPJOB® S connector,			
❻	can be snapped together, for jumper contact slot gray	2004-511	100 (4x25)
Spacer module, can be snapped together, e.g., for bridging commoned terminal blocks			
	gray	2004-549	100 (4x25)
End plate, for modular TOPJOB® S connectors, 1.5 mm thick			
	gray	2004-541	100 (4x25)
Test plug adapter, for 4 mm Ø test plug			
	gray	2009-174	100 (4x25)
Banana plug, for socket 4 mm Ø, color mixed			
		215-111	50
Testing tap, for max. 2.5 mm ²			
	gray	2009-182	100 (4x25)
Test plug, with 500 mm cable, 2 mm Ø			
	red	210-136	50
Test plug, with 500 mm cable, 2.3 mm Ø			
	yellow	210-137	50
WMB Multi marking system, 10 strips with 10 markers per card, stretchable 5 ... 5.2 mm			
	plain	793-5501	5
Marking strip, plain, 11 mm wide, 50 m roll			
	white	2009-110	1
TOPJOB® S group marker carrier, snap-on type for jumper slot, 5 mm wide			
	gray	2009-191	50 (2x25)
Screwless end stop, for DIN 35 rail, 6 mm wide			
	gray	249-116	100 (4x25)

TOPJOB® S Through/Ground Conductor and Ex Terminal Blocks 6 (10) mm², 2006 Series

PUSH-IN CAGE CLAMP®

0.5 ... 6 (10) mm ² ① 800 V/8 kV/3 ② I _N 41 A (57 A)	AWG 20 ... 8 600 V, 50 A [Ⓜ] 600 V, 50 A [Ⓢ]	0.5 ... 6 (10) mm ² ① 800 V/8 kV/3 ② I _N 41 A (57 A)	AWG 20 ... 8 600 V, 50 A [Ⓜ] 600 V, 50 A [Ⓢ]
Terminal block width 7.5 mm / 0.295 in. 13 ... 15 mm / 0.55 in. ③		Terminal block width 7.5 mm / 0.295 in. 13 ... 15 mm / 0.55 in. ③	

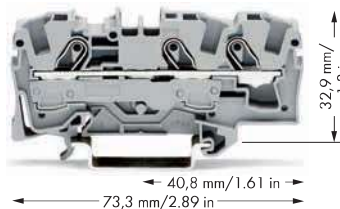

- ① Conductor sizes: 0.5 mm² ... 10 mm² "s + f-st"; Push-in conductor sizes: 1 mm² ... 10 mm² "s" and 1.5 mm² ... 6 mm² "insulated ferrule, 12 mm"
- ② 800 V = rated voltage
8 kV = rated surge voltage
3 = pollution degree
(see Full Line Catalog, Volume 1, Section 14)
- ③ Strip length, see packaging or instructions.
- ④ Suitable for Ex i applications
- ⑤ Suitable for Ex e II applications
550 V, 38 A for 2-conductor terminal blocks
550 V, 36 A for 3-conductor terminal blocks
Jumper 33 A
(see Full Line Catalog, Volume 1, Section 14)
- ⑥ See application notes for:
Ex e/Ex i separator plate, page 27
Star point jumper, page 165
TOPJOB® S connector, page 160

Item No.	Pack. Unit	Item No.	Pack. Unit
2-conductor through terminal block		3-conductor through terminal block	
gray ⑤ 2006-1201 ⑤	50	gray ⑤ 2006-1301 ⑤	25
blue ⑤ 2006-1204 ④ ⑤	50	blue ⑤ 2006-1304 ④ ⑤	25
orange ⑤ 2006-1202 ⑤	50	orange ⑤ 2006-1302 ⑤	25
2-conductor ground terminal block		3-conductor ground terminal block	
green-yellow ⑤ 2006-1207 ⑤	50	green-yellow ⑤ 2006-1307 ⑤	25
2-conductor shield terminal block			
white ⑤ 2006-1208 ⑤	50		



Lockout cap for covering unused clamping units of 2006 Series TOPJOB® S terminal blocks.

Item-Specific Accessories		Item-Specific Accessories	
End and intermediate plate, 1 mm thick		End and intermediate plate, 1 mm thick	
orange 2006-1292 100 (4x25)		orange 2006-1392 100 (4x25)	
gray 2006-1291 100 (4x25)		gray 2006-1391 100 (4x25)	
Separator, oversized, 2 mm thick		Separator, oversized, 2 mm thick	
orange 2006-1294 100 (4x25)		orange 2006-1394 100 (4x25)	
gray 2006-1293 100 (4x25)		gray 2006-1393 100 (4x25)	

2006 Series Accessories

Appropriate marking systems: WMB/Marking strips

Ex e/Ex i separator, orange, ⑥ 3 mm thick 120 mm 209-191 50 (2x25)	Step-down jumper, insulated, ⑥ I _N 32 A light gray 2006-499 50 (2x25)
Push-in type jumper bar, insulated, I _N 41 A, light gray 2-way 2006-402 50 (2x25) 3-way 2006-403 50 (2x25) 4-way 2006-404 50 (2x25) 5-way 2006-405 50 (2x25)	Protective warning marker, with high-voltage symbol, black, for 5 terminal blocks yellow 2006-115 100 (4x25)
Push-in type jumper bar, insulated, I _N 41 A, light gray from 1 to 3 2006-433 50 (2x25) from 1 to 4 2006-434 50 (2x25) from 1 to 5 2006-435 50 (2x25)	Lockout cap, for conductor entry hole and operating slot gray 2006-191 25
Star point jumper, insulated, ⑥ I _N = I _N terminal block, light gray 1-3-5 2006-405/011-000 50 (2x25)	Modular TOPJOB® S connector, ⑥ can be snapped together, for jumper contact slot gray 2006-511 50 (2x25)
	Test plug adapter, for 4 mm Ø test plug gray 2009-174 100 (4x25)
	WMB Multi marking system, 10 strips with 10 markers per card, stretchable 5 ... 5.2 mm plain 793-5501 5

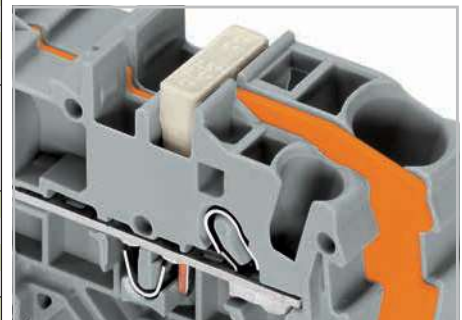

Commoning with step-down jumpers

An end plate must be inserted between the terminal blocks to be jumpered. Step-down jumper 2006-499 commons 6/4 mm² AWG 10/12 (2006/2004 Series) terminal blocks with 4/2.5/1.5 mm² AWG 12/14/16 (2004/2002/2001 Series) terminal blocks. Step-down jumpers are simply pushed down for full insertion, similar to other push-in type jumper bars. Note:

The total current flowing shall not exceed the rating of the step-down jumper/push-in type jumper bar.

TOPJOB® S

Through/Ground Conductor and Ex Terminal Blocks

10 (16) mm², 2010 Series

PUSH-IN CAGE CLAMP®

0.5 ... 10 (16) mm ² ① 800 V/8 kV/3 ② I _N 57 A (76 A)	AWG 20 ... 6 600 V, 65 A ④ 600 V, 65 A ⑤	0.5 ... 10 (16) mm ² ① 800 V/8 kV/3 ② I _N 57 A (76 A)	AWG 20 ... 6 600 V, 65 A ④ 600 V, 65 A ⑤
Terminal block width 10 mm / 0.394 in. 17 ... 19 mm / 0.71 in. ③		Terminal block width 10 mm / 0.394 in. 17 ... 19 mm / 0.71 in. ③	

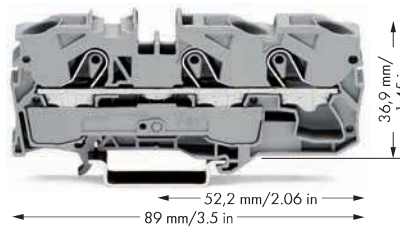
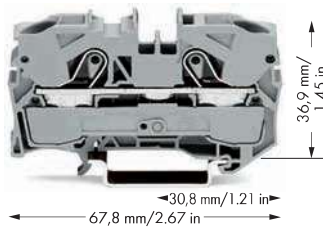

- ① Conductor sizes: 0.5 mm² ... 16 mm² "s + fst"; Push-in conductor sizes: 2.5 mm² ... 16 mm² "s" and 2.5 mm² ... 10 mm² "insulated ferrule, 18 mm"
- ② 800 V = rated voltage
8 kV = rated surge voltage
3 = pollution degree
(see Full Line Catalog, Volume 1, Section 14)
- ③ Strip length, see packaging or instructions.
- ④ Suitable for Ex i applications
- ⑤ Suitable for Ex e II applications
550 V, 51 A for 2-conductor terminal blocks
550 V, 50 A for 3-conductor terminal blocks
(see Full Line Catalog, Volume 1, Section 14)
- ⑥ See application notes for:
Ex e/Ex i separator plate, page 27
Star point jumper, page 165
TOPJOB® S connector, page 160

Item No.	Pack. Unit	Item No.	Pack. Unit
2-conductor through terminal block		3-conductor through terminal block	
gray ⑤	2010-1201 ⑤ 25	gray ⑤	2010-1301 ⑤ 25
blue ⑤	2010-1204 ④ ⑤ 25	blue ⑤	2010-1304 ④ ⑤ 25
orange ⑤	2010-1202 ⑤ 25	orange ⑤	2010-1302 ⑤ 25
2-conductor ground terminal block		3-conductor ground terminal block	
green-yellow ⑤	2010-1207 ⑤ 25	green-yellow ⑤	2010-1307 ⑤ 25
2-conductor shield terminal block			
white	2010-1208 ⑤ 25		
Item-Specific Accessories		Item-Specific Accessories	
End and intermediate plate, 1 mm thick		End and intermediate plate, 1 mm thick	
orange	2010-1292 100 (4x25)	orange	2010-1392 100 (4x25)
gray	2010-1291 100 (4x25)	gray	2010-1391 100 (4x25)
Ex e/Ex i separator, orange,			
⑥ 3 mm thick			
120 mm	209-191 50 (2x25)		
2010 Series Accessories			
Appropriate marking systems: WMB/Marking strips			
Push-in type jumper bar, insulated,		Protective warning marker,	
I _N 57 A, light gray		with high-voltage symbol, black,	
2-way	2010-402 50 (2x25)	for 5 terminal blocks	
3-way	2010-403 50 (2x25)	yellow	2010-115 50 (2x25)
4-way	2010-404 50 (2x25)	Finger guard,	
5-way	2010-405 50 (2x25)	touchproof cover protects unused conductor entries	
Push-in type jumper bar, insulated,		yellow	2010-100 100 (4x25)
I _N 57 A, light gray		Modular TOPJOB® S connector,	
from 1 to 3	2010-433 50 (2x25)	⑥ can be snapped together,	
from 1 to 4	2010-434 50 (2x25)	for jumper contact slot	
from 1 to 5	2010-435 50 (2x25)	gray	2010-511 50 (2x25)
Star point jumper, insulated,		Test plug adapter,	
⑥ I _N = I _N terminal block, light gray		for 4 mm Ø test plug	
1-3-5	2010-405/011-000 50 (2x25)	gray	2009-174 100 (4x25)
Step-down jumper, insulated,		WMB Multi marking system,	
⑥ I _N 57 A, light gray	2016-499 50 (2x25)	10 strips with 10 markers per card,	
		stretchable 5 ... 5.2 mm	
		plain	793-5501 5
		Marking strip, plain,	
		11 mm wide,	
		50 m roll	
		white	2009-110 1



Commoning with step-down jumpers
An end plate must be inserted between the terminal blocks to be jumpered. Step-down jumper 2016-499 commons 16/10 mm² AWG 16/8 (2016/2010 Series) terminal blocks with 10/6/4/2.5 mm² AWG 8/10/12/14 (2010/2006/2004/2002 Series) terminal blocks. Step-down jumpers are simply pushed down for full insertion, similar to other push-in type jumper bars.

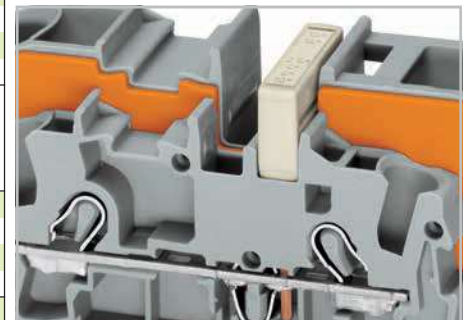

Note:
The total current flowing shall not exceed the rating of the step-down jumper/push-in type jumper bar.

TOPJOB® S

Through/Ground Conductor and Ex Terminal Blocks 16 (25 "f-st") mm², 2016 Series

PUSH-IN CAGE CLAMP®

0.5 ... 16 (25 "f-st") mm ² ① 800 V/8 kV/3 ② I _N 76 A (90 A)	AWG 20 ... 4 600 V, 85 A ④ 600 V, 85 A ⑤	0.5 ... 16 (25 "f-st") mm ² ① 800 V/8 kV/3 ② I _N 76 A (90 A)	AWG 20 ... 4 600 V, 85 A ④ 600 V, 85 A ⑤
Terminal block width 12 mm / 0.472 in. 18 ... 20 mm / 0.75 in. ③		Terminal block width 12 mm / 0.472 in. 18 ... 20 mm / 0.75 in. ③	

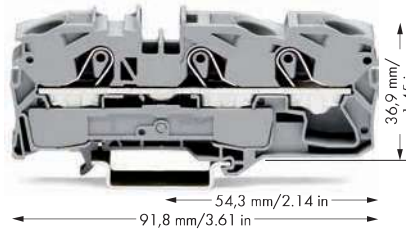
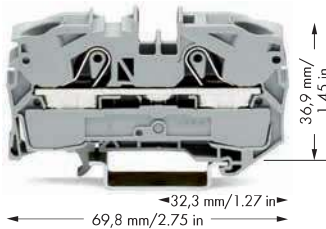

- ① Conductor sizes: 0.5 mm² ... 16 mm² "s + f-st", 25 mm² "f-st"; Push-in conductor sizes: 2.5 mm² ... 16 mm² "s" and 2.5 mm² ... 16 mm² "insulated ferrule, 18 mm"
- ② 800 V = rated voltage
8 kV = rated surge voltage
3 = pollution degree
(see Full Line Catalog, Volume 1, Section 14)
- ③ Strip length, see packaging or instructions.
- ④ Suitable for Ex i applications
- ⑤ Suitable for Ex e II applications
550 V, 70 A for 2-conductor terminal blocks
550 V, 67 A for 3-conductor terminal blocks
Jumper 65 A
(see Full Line Catalog, Volume 1, Section 14)
- ⑥ See application notes for:
Ex e/Ex i separator plate, page 27
Star point jumper, page 165
TOPJOB® S connector, page 161

Item No.	Pack. Unit	Item No.	Pack. Unit
2-conductor through terminal block		3-conductor through terminal block	
gray ⑤	2016-1201 ⑤ 20	gray ⑤	2016-1301 ⑤ 20
blue ⑤	2016-1204 ④ ⑤ 20	blue ⑤	2016-1304 ④ ⑤ 20
orange ⑤	2016-1202 ⑤ 20	orange ⑤	2016-1302 ⑤ 20
2-conductor ground terminal block, 15mm-high DIN 35 rails shall be used for a current load higher than 76A!		3-conductor ground terminal block, 15mm-high DIN 35 rails shall be used for a current load higher than 76A!	
green-yellow ⑤	2016-1207 ⑤ 20	green-yellow ⑤	2016-1307 ⑤ 20
2-conductor shield terminal block, 15mm-high DIN 35 rails shall be used for a current load higher than 76A!			
white	2016-1208 ⑤ 20		
Item-Specific Accessories		Item-Specific Accessories	
End and intermediate plate, 1 mm thick		End and intermediate plate, 1 mm thick	
orange	2016-1292 100 (4x25)	orange	2016-1392 100 (4x25)
gray	2016-1291 100 (4x25)	gray	2016-1391 100 (4x25)
Ex e/Ex i separator, orange, ⑥ 3 mm thick 120 mm			
	209-191 50 (2x25)		
2016 Series Accessories Appropriate marking systems: WMB/Marking strips			
Push-in type jumper bar, insulated, I _N 76 A, light gray		Step-down jumper, insulated, ⑥ I _N 57 A, light gray	
2-way	2016-402 50 (2x25)	light gray	2016-499 50 (2x25)
3-way	2016-403 50 (2x25)	Protective warning marker, with high-voltage symbol, black, for 5 terminal blocks	
4-way	2016-404 50 (2x25)	yellow	2016-115 50 (2x25)
5-way	2016-405 50 (2x25)	Modular TOPJOB® S connector, ⑥ can be snapped together, for jumper contact slot	
Push-in type jumper bar, insulated, I _N 76 A, light gray		gray	2016-511 50 (2x25)
from 1 to 3	2016-433 50 (2x25)	Finger guard, touchproof cover protects unused conductor entries	
from 1 to 4	2016-434 50 (2x25)	yellow	2016-100 100 (4x25)
from 1 to 5	2016-435 50 (2x25)	Test plug adapter, for 4 mm Ø test plug	
Star point jumper, insulated, ⑥ I _N = I _N terminal block, light gray 1-3-5		gray	2009-174 100 (4x25)
	2016-405/011-000 50 (2x25)		

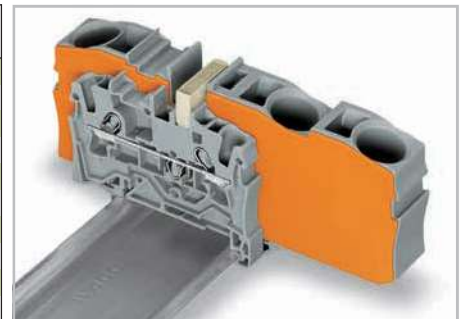

Commoning with step-down jumpers
An end plate must be inserted between the terminal blocks to be jumpered. Step-down jumper 2016-499 commons 16/10 mm² AWG 16/8 (2016/2010 Series) terminal blocks with 10/6/4/2.5 mm² AWG 8/10/12/14 (2010/2006/2004/2002 Series) terminal blocks. Step-down jumpers are simply pushed down for full insertion, similar to other push-in type jumper bars.



Inserting a finger guard seals unused conductor entries.

TESTING

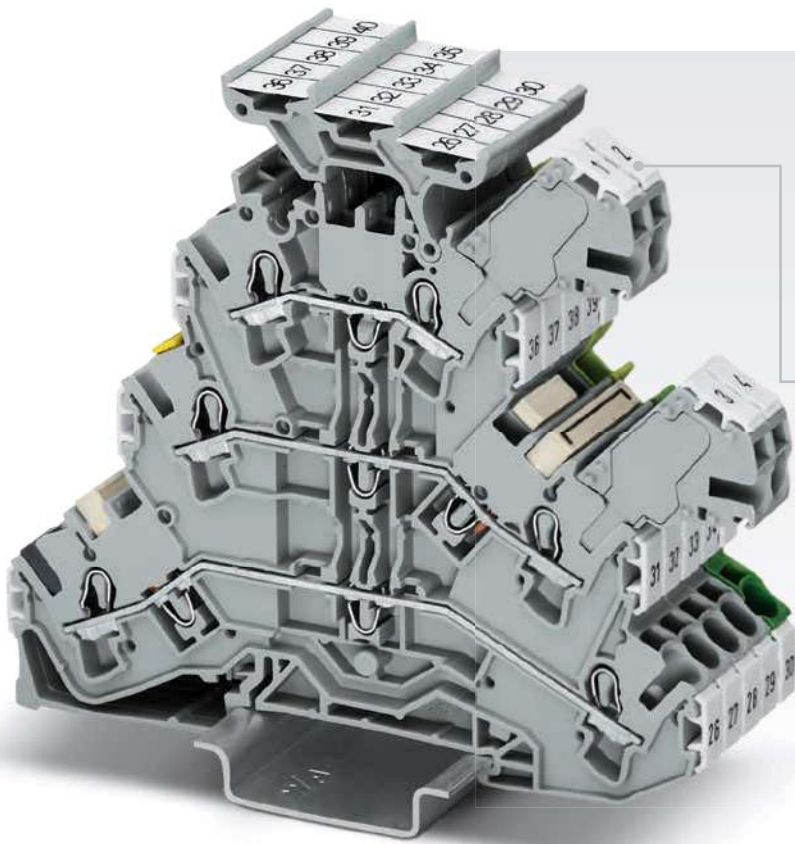

Modular Connectors

- Circuit identification via WMB markers
- Customizable to suit required number of poles

Test Plugs



The TOPJOB® S Test Plugs can be simply pushed into the conductor entry and then unplugged – no tools required. Test plugs are convenient workaround for multilevel terminal block assemblies with inaccessible jumper slots. Additionally, terminal blocks can be skipped using spacer modules.

Test Plug Adapter



Test plug adapters (CAT I) for 4 mm banana plugs are suited for 2000 ... 2016 Series.

Testing Tap



Testing taps are suited for 2000 ... 2016 Series, providing tool-free connection of test wires up to 2.5 mm² (12 AWG).

TOPJOB® S

Double-Deck Terminal Blocks 1 (1.5) mm²

2000 Series

0.14 ... 1 (1.5) mm ² ① 500 V/6 kV/3 ② I _N 13.5 A (16 A)	AWG 24 ... 16 600 V, 10 A ③	0.14 ... 1 (1.5) mm ² ① 500 V/6 kV/3 ② I _N 13.5 A (16 A)	AWG 24 ... 16 600 V, 10 A ③	0.14 ... 1 (1.5) mm ² ① 500 V/6 kV/3 ② I _N 13.5 A (16 A)	AWG 24 ... 16 600 V, 10 A ③
Terminal block width 3.5 mm / 0.138 in. 9 ... 11 mm / 0.39 in. ③		Terminal block width 3.5 mm / 0.138 in. 9 ... 11 mm / 0.39 in. ③		Terminal block width 3.5 mm / 0.138 in. 9 ... 11 mm / 0.39 in. ③	

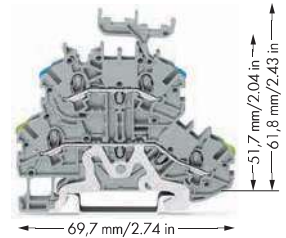
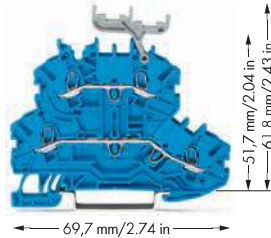
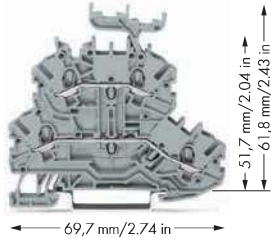

Item No.	Pack. Unit	Item No.	Pack. Unit	Item No.	Pack. Unit
Through/through terminal block, with marker carrier, gray housing		Through/through terminal block, with marker carrier, blue housing		Ground conductor/through terminal block, with marker carrier, gray housing	
○ L/L 2000-2231	50	● N/N 2000-2234	50	○ PE/N 2000-2247	50
○ N/L 2000-2232	50			○ PE/L 2000-2257	50
○ L/N 2000-2233	50				
Through/through terminal block, without marker carrier, gray housing		Through/through terminal block, without marker carrier, blue housing		Ground conductor/through terminal block, without marker carrier, gray housing	
○ L/L 2000-2201	50	● N/N 2000-2204	50	○ PE/N 2000-2217	50
○ N/L 2000-2202	50			○ PE/L 2000-2227	50
○ L/N 2000-2203	50				

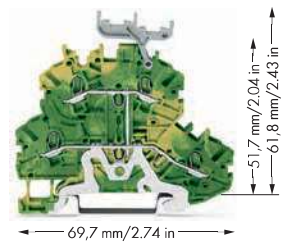
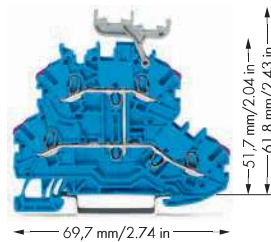
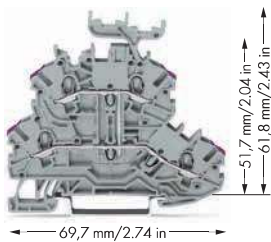

Item No.	Pack. Unit	Item No.	Pack. Unit	Item No.	Pack. Unit
4-conductor through terminal block, with marker carrier, internal commencing, conductor entry position colored in violet, gray housing		4-conductor through terminal block, with marker carrier, internal commencing, conductor entry position colored in violet, blue housing		4-conductor ground terminal block, with marker carrier, internal commencing, green-yellow housing	
○ L 2000-2238	50	● N 2000-2239	50	● PE 2000-2237	50
4-conductor through terminal block, without marker carrier, internal commencing, conductor entry position colored in violet, gray housing		4-conductor through terminal block, without marker carrier, internal commencing, conductor entry position colored in violet, blue housing		4-conductor ground terminal block, without marker carrier, internal commencing, green-yellow housing	
○ L 2000-2208	50	● N 2000-2209	50	● PE 2000-2207	50

0.14 ... 1 (1.5) mm² ① AWG 24 ... 16
 500 V/6 kV/3 ② 600 V, 10 A ④
 I_N 13.5 A (16 A)

Terminal block width 3.5 mm / 0.138 in.
 ③ 9 ... 11 mm / 0.39 in. ③

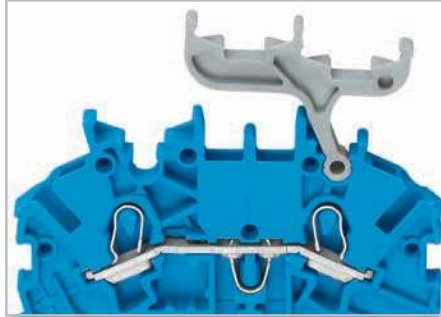
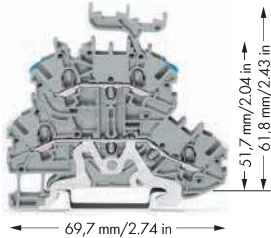

Double-deck terminal block assembly
 A double-deck marker carrier can be fitted retrospectively to double-deck terminal blocks without marker carrier.

- ① Conductor sizes: 0.14 mm² ... 1.5 mm² "s + f-st";
 Push-in conductor sizes: 0.5 mm² ... 1.5 mm² "s"
 and 0.5 mm² ... 0.75 mm²
 "insulated ferrule, 10 mm"
- ② 500 V = rated voltage
 6 kV = rated surge voltage
 3 = pollution degree
 (see Full Line Catalog, Volume 1, Section 14)
- ③ Strip length, see packaging or instructions.
- ④ See application notes for:
 Colored push-in type jumper bars, page 163
 Vertical jumper, page 167

Item No.	Pack. Unit	2000 Series Accessories	
Shield conductor/through terminal block, with marker carrier,		Appropriate marking systems: WMB/Marking strips	
gray housing		End and intermediate plate, 0.7 mm thick	
Shield/N	2000-2248	50	orange 2000-2292 25
Shield/L	2000-2258	50	gray 2000-2291 25
Shield conductor/through terminal block, without marker carrier,		Push-in type jumper bar, insulated,	
gray housing		④ I _N 14 A,	
Shield/N	2000-2218	50	light gray
Shield/L	2000-2228	50	2-way 2000-402 200 (8x25)
			3-way 2000-403 200 (8x25)
			4-way 2000-404 200 (8x25)
			5-way 2000-405 100 (4x25)
			6-way 2000-406 100 (4x25)
			7-way 2000-407 100 (4x25)
			8-way 2000-408 100 (4x25)
			9-way 2000-409 100 (4x25)
			10-way 2000-410 100 (4x25)
		Push-in type jumper bar, insulated,	
		I _N 14 A,	
		light gray	
		from 1 to 3 2000-433 200 (8x25)	
		from 1 to 4 2000-434 200 (8x25)	
		from 1 to 5 2000-435 100 (4x25)	
		from 1 to 6 2000-436 100 (4x25)	
		from 1 to 7 2000-437 100 (4x25)	
		from 1 to 8 2000-438 100 (4x25)	
		from 1 to 9 2000-439 100 (4x25)	
		from 1 to 10 2000-440 100 (4x25)	
		Double-deck vertical jumper, insulated,	
		④ I _N 13.5 A	
		light gray 2000-492 100 (4x25)	
		Protective warning marker,	
		with high-voltage symbol, black,	
		for 5 terminal blocks	
		yellow 2000-115 100 (4x25)	
		Double-deck marker carrier,	
		pivoting	
		gray 2000-121 50 (2x25)	
		WMB Multi marking system,	
		10 strips with 10 markers per card,	
		for 3.5 mm terminal block width	
		plain 793-3501 5	
		Marking strip, plain,	
		11 mm wide,	
		50 m roll	
		white 2009-110 1	

TOPJOB® S

Double-Deck Terminal Blocks 1 (1.5) mm²

2000 Series

0.14 ... 1 (1.5) mm ² ① 800 V/8 kV/3 ② I _N 13.5 A (16 A)	AWG 24 ... 16 600 V, 10 A ③	0.14 ... 1 (1.5) mm ² ① 800 V/8 kV/3 ② I _N 13.5 A (16 A)	AWG 24 ... 16 600 V, 10 A ③	0.14 ... 1 (1.5) mm ² ① 800 V/8 kV/3 ② I _N 13.5 A (16 A)	AWG 24 ... 16 600 V, 10 A ③
Terminal block width 4.2 mm / 0.165 in. 9 ... 11 mm / 0.39 in ④		Terminal block width 4.2 mm / 0.165 in. 9 ... 11 mm / 0.39 in ④		Terminal block width 4.2 mm / 0.165 in. 9 ... 11 mm / 0.39 in ④	

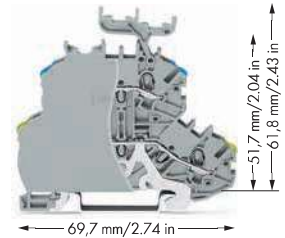
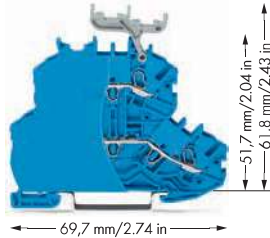
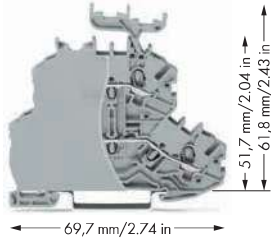

Item No.	Pack. Unit	Item No.	Pack. Unit	Item No.	Pack. Unit
Through/through terminal block, with end plate, with marker carrier, gray housing		Through/through terminal block, with end plate, with marker carrier, blue housing		Ground conductor/through terminal block, with end plate, with marker carrier, gray housing	
○ L/L	2000-2231/099-000 50	● N/N	2000-2234/099-000 50	○ PE/N	2000-2247/099-000 50
○ N/L	2000-2232/099-000 50			○ PE/L	2000-2257/099-000 50
○ L/N	2000-2233/099-000 50				
Through/through terminal block, with end plate, without marker carrier, gray housing		Through/through terminal block, with end plate, without marker carrier, blue housing		Ground conductor/through terminal block, with end plate, without marker carrier, gray housing	
○ L/L	2000-2201/099-000 50	● N/N	2000-2204/099-000 50	○ PE/N	2000-2217/099-000 50
○ N/L	2000-2202/099-000 50			○ PE/L	2000-2227/099-000 50
○ L/N	2000-2203/099-000 50				

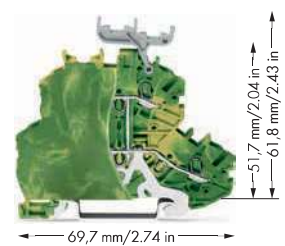
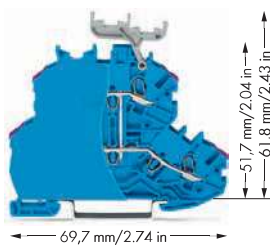
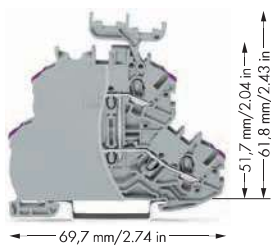

Item No.	Pack. Unit	Item No.	Pack. Unit	Item No.	Pack. Unit
4-conductor through terminal block, with end plate, with marker carrier, internal commoning, conductor entry position colored in violet, gray housing		4-conductor through terminal block, with end plate, with marker carrier, internal commoning, conductor entry position colored in violet, blue housing		4-conductor ground terminal block, with end plate, with marker carrier, internal commoning, green-yellow housing	
○ L	2000-2238/099-000 50	● N	2000-2239/099-000 50	● PE	2000-2237/099-000 50
4-conductor through terminal block, with end plate, without marker carrier, internal commoning, conductor entry position colored in violet, gray housing		4-conductor through terminal block, with end plate, without marker carrier, internal commoning, conductor entry position colored in violet, blue housing		4-conductor ground terminal block, with end plate, without marker carrier, internal commoning, green-yellow housing	
○ L	2000-2208/099-000 50	● N	2000-2209/099-000 50	● PE	2000-2207/099-000 50

Approvals see www.wago.com

0.14 ... 1 (1.5) mm² ① | AWG 24 ... 16
 800 V/8 kV/3 ② | 600 V, 10 A ④
 I_N 13.5 A (16 A)

Terminal block width 4.2 mm / 0.165 in.

③ 9 ... 11 mm / 0.39 in

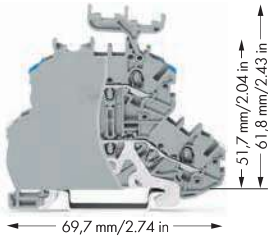

Double-deck terminal block assembly
 A double-deck marker carrier can be fitted retrospectively to double-deck terminal blocks without marker carrier.

- ① Conductor sizes: 0.14 mm² ... 1.5 mm² "s + f-st"; Push-in conductor sizes: 0.5 mm² ... 1.5 mm² "s" and 0.5 mm² ... 0.75 mm² "insulated ferrule, 10 mm"
- ② 800 V = rated voltage
 8 kV = rated surge voltage
 3 = pollution degree
 (see Full Line Catalog, Volume 1, Section 14)
- ③ Strip length, see packaging or instructions.
- ④ See application notes for:
 Vertical jumper, page 167

Item No.	Pack. Unit	2000 Series Accessories	
Shield conductor/through terminal block, with end plate, with marker carrier, gray housing		Appropriate marking systems: WMB/Marking strips	
Shield/N	2000-2248/099-000	50	
Shield/L	2000-2258/099-000	50	
Shield conductor/through terminal block, with end plate, without marker carrier, gray housing		End and intermediate plate, 0.7 mm thick	
Shield/N	2000-2218/099-000	50	
Shield/L	2000-2228/099-000	50	
		Push-in type jumper bar, insulated, I _N 18 A, light gray	
		2-way	2001-402 200 (8x25)
		3-way	2001-403 200 (8x25)
		4-way	2001-404 200 (8x25)
		5-way	2001-405 100 (4x25)
		6-way	2001-406 100 (4x25)
		7-way	2001-407 100 (4x25)
		8-way	2001-408 100 (4x25)
		9-way	2001-409 100 (4x25)
		10-way	2001-410 100 (4x25)
		Push-in type jumper bar, insulated, I _N 18 A, light gray	
		from 1 to 3	2001-433 200 (8x25)
		from 1 to 4	2001-434 200 (8x25)
		from 1 to 5	2001-435 100 (4x25)
		from 1 to 6	2001-436 100 (4x25)
		from 1 to 7	2001-437 100 (4x25)
		from 1 to 8	2001-438 100 (4x25)
		from 1 to 9	2001-439 100 (4x25)
		from 1 to 10	2001-440 100 (4x25)
		Double-deck vertical jumper, insulated, I _N 13.5 A, light gray	
			2000-492 100 (4x25)
		Protective warning marker, with high-voltage symbol, black, for 5 terminal blocks, yellow	
			2001-115 100 (4x25)
		Double-deck marker carrier, pivoting, gray	
			2000-121 50 (2x25)
		Marking strip, plain, 11 mm wide, 50 m roll, white	
			2009-110 1
		Test plug adapter, for 4 mm Ø test plug, gray	
			2009-174 100 (4x25)
		Testing tap, for max. 2.5 mm ² , gray	
			2009-182 100 (4x25)
		Banana plug, for socket 4 mm Ø, color mixed	
			215-111 50
		WMB Inline, plain, stretchable 4 ... 4.2 mm, 2,000 WMB markers, 4 mm, on roll, white	
			2009-114 1
		WMB Multi marking system, 10 strips with 10 markers per card, stretchable 4 ... 4.2 mm, plain	
			793-4501 5
		WMB Multi marking system, plain, 10 strips with 10 markers per card, stretchable 4 ... 4.2 mm	
		yellow	793-4501/000-002
		red	793-4501/000-005
		blue	793-4501/000-006
		gray	793-4501/000-007
		orange	793-4501/000-012
		light green	793-4501/000-017
		green	793-4501/000-023
		violet	793-4501/000-024
			5

TOPJOB® S

Double-Deck Terminal Blocks 2.5 (4) mm²

2002 Series

0.25 ... 2.5 (4) mm ² ① 500 V/6 kV/3 ② I _N 24 A (28 A)	AWG 22 ... 12 600 V, 20 A ③ 600 V, 20 A ④	0.25 ... 2.5 (4) mm ² ① 500 V/6 kV/3 ② I _N 24 A (28 A)	AWG 22 ... 12 600 V, 20 A ③ 600 V, 20 A ④	0.25 ... 2.5 (4) mm ² ① 500 V/6 kV/3 ② I _N 24 A (28 A)	AWG 22 ... 12 600 V, 20 A ③ 600 V, 20 A ④
Terminal block width 5.2 mm / 0.205 in. □ 10 ... 12 mm / 0.43 in. ③		Terminal block width 5.2 mm / 0.205 in. □ 10 ... 12 mm / 0.43 in. ③		Terminal block width 5.2 mm / 0.205 in. □ 10 ... 12 mm / 0.43 in. ③	

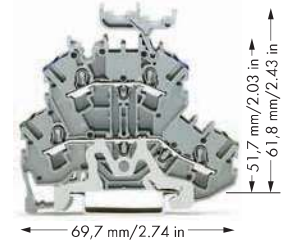
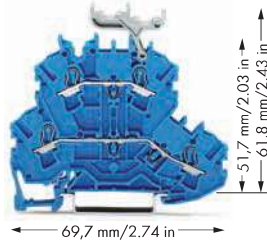
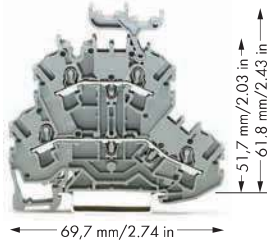

Item No.	Pack. Unit	Item No.	Pack. Unit	Item No.	Pack. Unit
Through/through terminal block, with marker carrier, gray housing		Through/through terminal block, with marker carrier, blue housing		Ground conductor/through terminal block, with marker carrier, gray housing	
○ L/L ⑤	2002-2231 ⑤ 50	● N/N ⑤	2002-2234 ④ ⑤ 50	○ PE/N ⑤	2002-2247 ⑤ 50
○ N/L ⑤	2002-2232 ⑤ 50			○ PE/L ⑤	2002-2257 ⑤ 50
○ L/N ⑤	2002-2233 ⑤ 50				
Through/through terminal block, without marker carrier, gray housing		Through/through terminal block, without marker carrier, blue housing		Ground conductor/through terminal block, without marker carrier, gray housing	
○ L/L ⑤	2002-2201 ⑤ 50	● N/N ⑤	2002-2204 ④ ⑤ 50	○ PE/N ⑤	2002-2217 ⑤ 50
○ N/L ⑤	2002-2202 ⑤ 50			○ PE/L ⑤	2002-2227 ⑤ 50
○ L/N ⑤	2002-2203 ⑤ 50				
Other terminal blocks with the same profile:					
Diode	2002-2211/1000-410	Page98			
LED	2002-2221/1000-434	Page98			

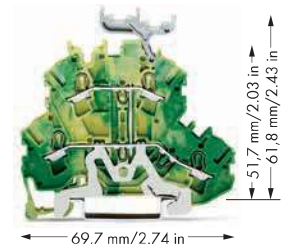
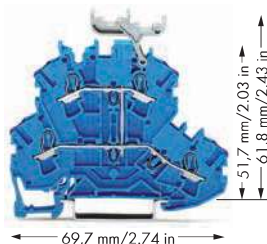
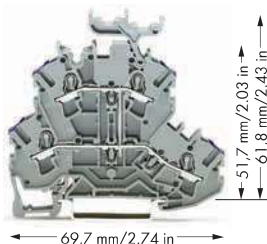

Item No.	Pack. Unit	Item No.	Pack. Unit	Item No.	Pack. Unit
4-conductor through terminal block, with marker carrier, internal commoning, conductor entry position colored in violet, gray housing		4-conductor through terminal block, with marker carrier, internal commoning, conductor entry position colored in violet, blue housing		4-conductor ground terminal block, with marker carrier, internal commoning, green-yellow housing	
○ L ⑤	2002-2238 ⑤ 50	● N ⑤	2002-2239 ④ ⑤ 50	● PE ⑤	2002-2237 ⑤ 50
4-conductor through terminal block, without marker carrier, internal commoning, conductor entry position colored in violet, gray housing		4-conductor through terminal block, without marker carrier, internal commoning, conductor entry position colored in violet, blue housing		4-conductor ground terminal block, without marker carrier, internal commoning, green-yellow housing	
○ L ⑤	2002-2208 ⑤ 50	● N ⑤	2002-2209 ④ ⑤ 50	● PE ⑤	2002-2207 ⑤ 50

0.25 ... 2.5 (4) mm² ① AWG 22 ... 12
 500 V/6 kV/3 ② 600 V, 20 A ③
 I_N 24 A (28 A) 600 V, 20 A ④
 Terminal block width 5.2 mm / 0.205 in.
 10 ... 12 mm / 0.43 in. ⑤



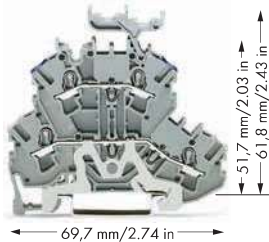

Double-deck terminal block assembly





- ① Conductor sizes: 0.25 mm² ... 4 mm² "s + fst";
 Push-in conductor sizes: 0.75 mm² ... 4 mm² "s"
 and 0.75 mm² ... 2.5 mm²
 "insulated ferrule, 1.2 mm"
- ② 500 V = rated voltage
 6 kV = rated surge voltage
 3 = pollution degree
 (see Full Line Catalog, Volume 1, Section 14)
- ③ Strip length, see packaging or instructions.
- ④ Suitable for Ex i applications
- ⑤ Suitable for Ex e II applications
 440 V, 20 A
 Jumper 18 A
 (see Full Line Catalog, Volume 1, Section 14)
- ⑥ See application notes for:
 Colored push-in type jumper bars, page 163
 Vertical jumper, page 167

2002 Series Accessories

Appropriate marking systems: WMB/
 WMB Inline/Marking strips

End and intermediate plate, 0.8 mm thick		
	orange	2002-2292 100 (4x25)
	gray	2002-2291 100 (4x25)

Ex e/Ex i separator, orange,		
	3 mm thick	
⑥	125.5 mm	209-192 50 (2x25)

Double-deck marker carrier,		
	pivoting	
	gray	2002-121 50 (2x25)



Insulation stop,		
	5 pcs/strip, 0.25 ... 0.5 mm ²	
	light gray	2002-171 200 (8x25)

Insulation stop,		
	5 pcs/strip, 0.75 ... 1 mm ²	
	dark gray	2002-172 200 (8x25)

Push-in type jumper bar, insulated,		
	I _N 25 A, light gray	
⑥	2-way	2002-402 200 (8x25)
	3-way	2002-403 200 (8x25)
	4-way	2002-404 200 (8x25)
	5-way	2002-405 100 (4x25)
	6-way	2002-406 100 (4x25)
	7-way	2002-407 100 (4x25)
	8-way	2002-408 100 (4x25)
	9-way	2002-409 100 (4x25)
	10-way	2002-410 100 (4x25)

Push-in type jumper bar, insulated,		
	I _N 25 A, light gray	
⑥	from 1 to 3	2002-433 200 (8x25)
	from 1 to 4	2002-434 200 (8x25)
	from 1 to 5	2002-435 100 (4x25)
	from 1 to 6	2002-436 100 (4x25)
	from 1 to 7	2002-437 100 (4x25)
	from 1 to 8	2002-438 100 (4x25)
	from 1 to 9	2002-439 100 (4x25)
	from 1 to 10	2002-440 100 (4x25)



Double-deck vertical jumper, insulated,		
	I _N 24 A, light gray	
⑥	orange	2002-492 100 (4x25) 2002-492/000-012

Item No.	Pack. Unit
Shield conductor/through terminal block, with marker carrier, gray housing	
 Shield/N	2002-2248 50
 Shield/L	2002-2258 50

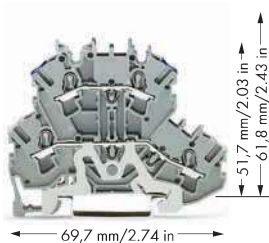

The ground conductor or shield terminal blocks have a contact foot in the bottom level, automatically establishing direct contact to the carrier rail. The flexible double-deck marker carrier, which is placed above the wiring levels, can be pushed aside during the wiring or commoning operation. The marker carrier has two levels for two different WMB markers relating to the two decks of the terminal blocks. With a terminal block width of only 5.2 mm an effective width of only 2.6 mm for terminal blocks of same or different potentials can be realized for conductor sizes from 0.25 mm² ... 4 mm² (AWG 22 ... 12). For protection against external interfering signals, an increasing number of shielded control cables are being used. Shield terminal blocks for front-entry are suitable for connecting the cable braid. Like ground conductor terminal blocks for front-entry, they are equipped with a grounding foot for direct electrical connection to the rail, however they differ significantly by their white insulated housing. Shield terminal blocks can be directly mounted beside signal-conductor terminal blocks and provide excellent deflection of interfering signals.



Item No.	Pack. Unit
Shield conductor/through terminal block, without marker carrier, gray housing	
 Shield/N	2002-2218 50
 Shield/L	2002-2228 50

TOPJOB® S

Double-Deck Terminal Blocks 2.5 (4) mm²

2002 Series

0.25 ... 2.5 (4) mm ² ① 800 V/8 kV/3 ② I _N 24 A	AWG 22 ... 12 600 V, 20 A ③ 600 V, 20 A ④	0.25 ... 2.5 (4) mm ² ① 800 V/8 kV/3 ② I _N 24 A	AWG 22 ... 12 600 V, 20 A ③ 600 V, 20 A ④	0.25 ... 2.5 (4) mm ² ① 800 V/8 kV/3 ② I _N 24 A	AWG 22 ... 12 600 V, 20 A ③ 600 V, 20 A ④
Terminal block width 6.2 mm / 0.244 in. 10 ... 12 mm / 0.43 in. ③		Terminal block width 6.2 mm / 0.244 in. 10 ... 12 mm / 0.43 in. ③		Terminal block width 6.2 mm / 0.244 in. 10 ... 12 mm / 0.43 in. ③	

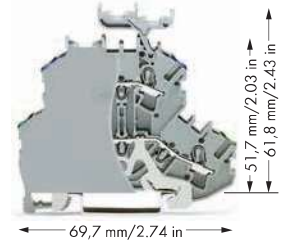
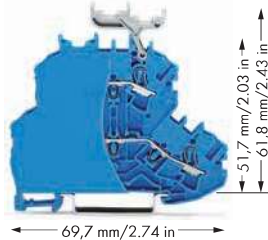
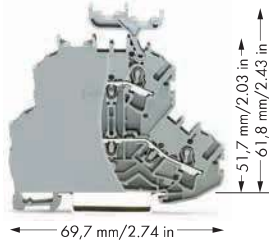

Item No.	Pack. Unit	Item No.	Pack. Unit	Item No.	Pack. Unit
Through/through terminal block, with end plate, with marker carrier, gray housing		Through/through terminal block, with end plate, with marker carrier, blue housing		Ground conductor/through terminal block, with end plate, with marker carrier, gray housing	
○ L/L	2002-2231/099-000 50	● N/N	2002-2234/099-000 ④ 50	○ PE/N	2002-2247/099-000 50
○ N/L	2002-2232/099-000 50			○ PE/L	2002-2257/099-000 50
○ L/N	2002-2233/099-000 50				
Through/through terminal block, with end plate, without marker carrier, gray housing		Through/through terminal block, with end plate, without marker carrier, blue housing		Ground conductor/through terminal block, with end plate, without marker carrier, gray housing	
○ L/L	2002-2201/099-000 50	● N/N	2002-2204/099-000 ④ 50	○ PE/N	2002-2217/099-000 50
○ N/L	2002-2202/099-000 50			○ PE/L	2002-2227/099-000 50
○ L/N	2002-2203/099-000 50				
Other terminal blocks with the same profile:					
Diode	2002-2211/1000-410	Page98			
LED	2002-2221/1000-434	Page98			

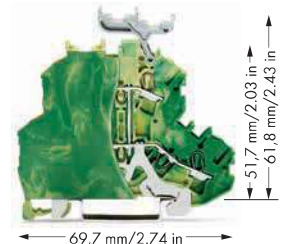
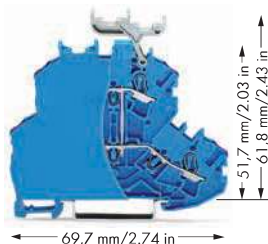
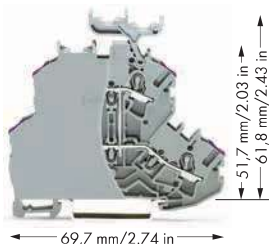

Item No.	Pack. Unit	Item No.	Pack. Unit	Item No.	Pack. Unit
4-conductor through terminal block, with end plate, with marker carrier, internal commoning, conductor entry position colored in violet, gray housing		4-conductor through terminal block, with end plate, with marker carrier, internal commoning, conductor entry position colored in violet, blue housing		4-conductor ground terminal block, with end plate, with marker carrier, internal commoning, green-yellow housing	
○ L	2002-2238/099-000 50	● N	2002-2239/099-000 ④ 50	● PE	2002-2237/099-000 50
4-conductor through terminal block, with end plate, without marker carrier, internal commoning, conductor entry position colored in violet, gray housing		4-conductor through terminal block, with end plate, without marker carrier, internal commoning, conductor entry position colored in violet, blue housing		4-conductor ground terminal block, with end plate, without marker carrier, internal commoning, green-yellow housing	
○ L	2002-2208/099-000 50	● N	2002-2209/099-000 ④ 50	● PE	2002-2207/099-000 50

0.25 ... 2.5 (4) mm² ① AWG 22 ... 12
 800 V/8 kV/3 ② 600 V, 20 A ④
 I_N 24 A 600 V, 20 A ⑤

Terminal block width 6.2 mm / 0.244 in.
 ③ 10 ... 12 mm / 0.43 in. ③

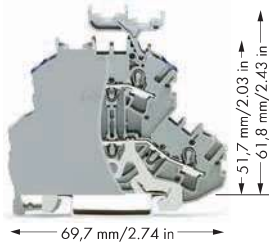

Protective warning marker and insulation stop must be applied individually. Due to the 6.2 mm width of double-deck terminal blocks with end plate, 2004 Series jumpers must be used.

- ① Conductor sizes: 0.25 mm² ... 4 mm² "s + f-st"; Push-in conductor sizes: 0.75 mm² ... 4 mm² "s" and 0.75 mm² ... 2.5 mm² "insulated ferrule, 12 mm"
- ② 800 V = rated voltage
 8 kV = rated surge voltage
 3 = pollution degree
 (see Full Line Catalog, Volume 1, Section 14)
- ③ Strip length, see packaging or instructions.
- ④ Suitable for Ex i applications
- ⑤ See application notes for: Vertical jumper, page 167

Item No.	Pack. Unit	2002 Series Accessories	
Shield conductor/through terminal block, with end plate, with marker carrier, gray housing		Appropriate marking systems: WMB/WMB Inline/Marking strips	
Shield/N	2002-2248/099-000 50	End and intermediate plate, 0.8 mm thick orange 2002-2292 100 (4x25) gray 2002-2291 100 (4x25)	Test plug adapter, for 4 mm Ø test plug gray 2009-174 100 (4x25)
Shield/L	2002-2258/099-000 50		
Shield conductor/through terminal block, with end plate, without marker carrier, gray housing		Double-deck marker carrier, pivoting gray 2002-121 50 (2x25)	
Shield/N	2002-2218/099-000 50	Insulation stop, 5 pcs/strip, 0.25 ... 0.5 mm ² light gray 2002-171 200 (8x25)	Banana plug, for socket 4 mm Ø, color mixed 215-111 50
Shield/L	2002-2228/099-000 50		
Insulation stop, 5 pcs/strip, 0.75 ... 1 mm ² dark gray 2002-172 200 (8x25)		WMB Multi marking system, 10 strips with 10 markers per card, stretchable 5 ... 5.2 mm plain 793-5501 5	
Push-in type jumper bar, insulated, I _N 32 A, light gray		WMB Multi marking system, plain, 10 strips with 10 markers per card, stretchable 5 ... 5.2 mm	
	2-way 2004-402 200 (8x25)	yellow 793-5501/000-002	
	3-way 2004-403 200 (8x25)	red 793-5501/000-005	
	4-way 2004-404 100 (4x25)	blue 793-5501/000-006	
	5-way 2004-405 100 (4x25)	gray 793-5501/000-007	
	6-way 2004-406 100 (4x25)	orange 793-5501/000-012	
	7-way 2004-407 100 (4x25)	light green 793-5501/000-017	
	8-way 2004-408 100 (4x25)	green 793-5501/000-023	
	9-way 2004-409 100 (4x25)	violet 793-5501/000-024	
	10-way 2004-410 100 (4x25)	5	
Push-in type jumper bar, insulated, I _N 32 A, light gray		Marking strip, plain, 11 mm wide, 50 m roll white 2009-110 1	
	from 1 to 3 2004-433 200 (8x25)		
	from 1 to 4 2004-434 200 (8x25)		
	from 1 to 5 2004-435 100 (4x25)		
	from 1 to 6 2004-436 100 (4x25)		
	from 1 to 7 2004-437 100 (4x25)		
	from 1 to 8 2004-438 100 (4x25)		
	from 1 to 9 2004-439 100 (4x25)		
	from 1 to 10 2004-440 100 (4x25)		
Double-deck vertical jumper, insulated, I _N 24 A			
	light gray 2002-492 100 (4x25)		
	orange 2002-492/000-012		
Protective warning marker, with high-voltage symbol, black, for 5 terminal blocks			
	yellow 2002-115 100 (4x25)		

TOPJOB® S

4-Conductor, Double-Deck Terminal Blocks 2.5 (4) mm²

2002 Series

0.25 ... 2.5 (4) mm ² ① 800 V/8 kV/3 ② I _N 24 A (28 A)	AWG 22 ... 12 600 V, 20 A ④ 600 V, 20 A ⑤	0.25 ... 2.5 (4) mm ² ① 800 V/8 kV/3 ② I _N 24 A (28 A)	AWG 22 ... 12 600 V, 20 A ④ 600 V, 20 A ⑤	0.25 ... 2.5 (4) mm ² ① 800 V/8 kV/3 ② I _N 24 A (28 A)	AWG 22 ... 12 600 V, 20 A ④ 600 V, 20 A ⑤
Terminal block width 5.2 mm / 0.205 in. □ 10 ... 12 mm / 0.43 in. ③		Terminal block width 5.2 mm / 0.205 in. □ 10 ... 12 mm / 0.43 in. ③		Terminal block width 5.2 mm / 0.205 in. □ 10 ... 12 mm / 0.43 in. ③	

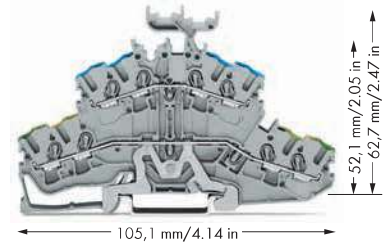
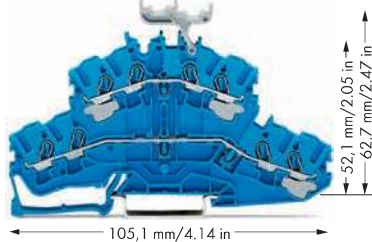
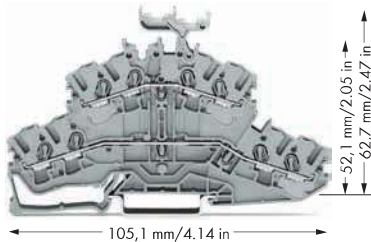

Item No.	Pack. Unit	Item No.	Pack. Unit	Item No.	Pack. Unit
Through/through terminal block, with marker carrier, gray housing		Through/through terminal block, with marker carrier, blue housing		Ground conductor/through terminal block, with marker carrier, gray housing	
○ L/L 2002-2431	50	● N/N 2002-2434 ④	50	○ PE/N 2002-2447	50
○ N/L 2002-2432	50			○ PE/L 2002-2457	50
○ L/N 2002-2433	50				
Through/through terminal block, without marker carrier, gray housing		Through/through terminal block, without marker carrier, blue housing		Ground conductor/through terminal block, without marker carrier, gray housing	
○ L/L 2002-2401	50	● N/N 2002-2404 ④	50	○ PE/N 2002-2417	50
○ N/L 2002-2402	50			○ PE/L 2002-2427	50
○ L/N 2002-2403	50				
Ex Approvals are pending					

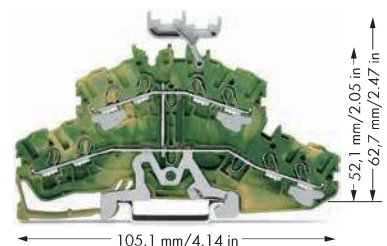
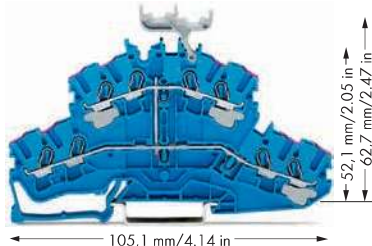
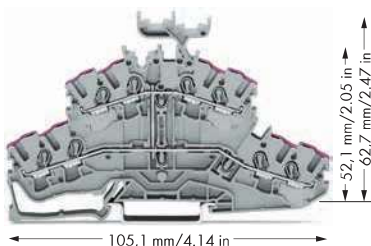

Item No.	Pack. Unit	Item No.	Pack. Unit	Item No.	Pack. Unit
8-conductor through terminal block, with marker carrier, internal commoning, conductor entry position colored in violet, gray housing		8-conductor through terminal block, with marker carrier, internal commoning, conductor entry position colored in violet, blue housing		8-conductor ground terminal block, with marker carrier, internal commoning, green-yellow housing	
○ L 2002-2438	50	● N 2002-2439 ④	50	● PE 2002-2437	50
8-conductor through terminal block, without marker carrier, internal commoning, conductor entry position colored in violet, gray housing		8-conductor through terminal block, without marker carrier, internal commoning, conductor entry position colored in violet, blue housing		8-conductor ground terminal block, without marker carrier, internal commoning, green-yellow housing	
○ L 2002-2408	50	● N 2002-2409 ④	50	● PE 2002-2407	50

0.25 ... 2.5 (4) mm² ① AWG 22 ... 12
 800 V/8 kV/3 ② 600 V, 20 A ④
 I_N 24 A (28 A) 600 V, 20 A ⑤
 Terminal block width 5.2 mm / 0.205 in.
 ③ 10 ... 12 mm / 0.43 in. ③

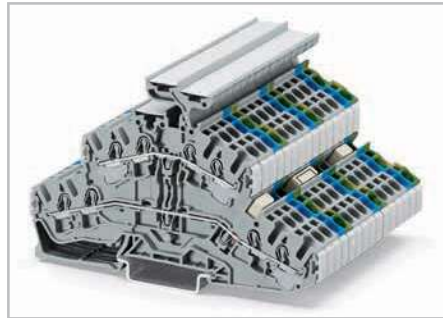
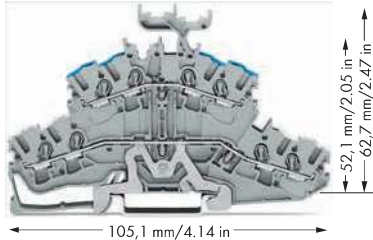

Double-deck terminal block assembly

- ① Conductor sizes: 0.25 mm² ... 4 mm² "s + f-st";
 Push-in conductor sizes: 0.75 mm² ... 4 mm² "s"
 and 0.75 mm² ... 2.5 mm²
 "insulated ferrule, 12 mm"
- ② 800 V = rated voltage
 8 kV = rated surge voltage
 3 = pollution degree
 (see Full Line Catalog, Volume 1, Section 14)
- ③ Strip length, see packaging or instructions.
- ④ Suitable for Ex i applications
- ⑤ See application notes for:
 Colored push-in type jumper bars, page 163
 Vertical jumper, page 167

Item No.	Pack. Unit	2002 Series Accessories	
Shield conductor/through terminal block, with marker carrier, gray housing		Appropriate marking systems: WMB/WMB Inline/Marking strips	
Shield/N	2002-2448	50	
Shield/L	2002-2458	50	
Shield conductor/through terminal block, without marker carrier, gray housing		End and intermediate plate, 0.8 mm thick	
Shield/N	2002-2418	50	orange 2002-2492 100 (4x25)
Shield/L	2002-2428	50	gray 2002-2491 100 (4x25)
		Double-deck marker carrier, pivoting	
		gray 2002-121 50 (2x25)	
		Insulation stop, 5 pcs/strip, 0.25 ... 0.5 mm ²	
		light gray 2002-171 200 (8x25)	
		Insulation stop, 5 pcs/strip, 0.75 ... 1 mm ²	
		dark gray 2002-172 200 (8x25)	
		Push-in type jumper bar, insulated, I _N 25 A, light gray	
		2-way 2002-402 200 (8x25)	
		3-way 2002-403 200 (8x25)	
		4-way 2002-404 200 (8x25)	
		5-way 2002-405 100 (4x25)	
		6-way 2002-406 100 (4x25)	
		7-way 2002-407 100 (4x25)	
		8-way 2002-408 100 (4x25)	
		9-way 2002-409 100 (4x25)	
		10-way 2002-410 100 (4x25)	
		WMB Multi marking system, 10 strips with 10 markers per card, stretchable 5 ... 5.2 mm, plain	
		793-5501 5	
		WMB Multi marking system, plain, 10 strips with 10 markers per card, stretchable 5 ... 5.2 mm	
		yellow 793-5501/000-002	
		red 793-5501/000-005	
		blue 793-5501/000-006	
		gray 793-5501/000-007	
		orange 793-5501/000-012	
		light green 793-5501/000-017	
		green 793-5501/000-023	
		violet 793-5501/000-024	
		5	
		WMB Inline, plain, stretchable 5 ... 5.2 mm, 1,500 WMB markers, 5 mm, on roll	
		white 2009-115 1	
		Marking strip, plain, 11 mm wide, 50 m roll	
		white 2009-110 1	
		TOPJOB® S group marker carrier, snap-on type for jumper slot, 5 mm wide	
		gray 2009-191 50 (2x25)	
		Double-deck vertical jumper, insulated, I _N 24 A, light gray	
		2002-492 100 (4x25)	
		orange 2002-492/000-012	
		Protective warning marker, with high-voltage symbol, black, for 5 terminal blocks	
		yellow 2002-115 100 (4x25)	

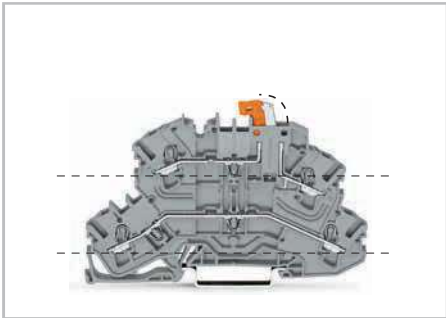

Multifunctional terminal blocks: The double-deck disconnect terminal block with movable knife disconnect (2002-2671) can be used as through terminal block on the lower deck and as disconnect terminal block on the upper deck.

Besides disconnection and measurement, the **2002-2667 double-deck carrier terminal block** also provides ground conductor functionality.

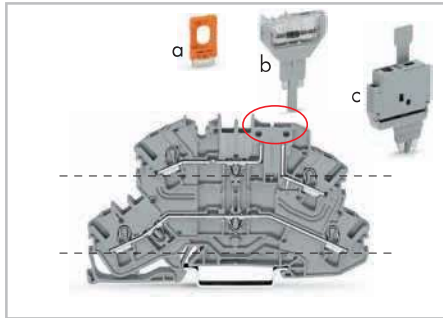

The associated **carrier terminal block (2002-2661)** has the same design as the disconnect terminal block. However, disconnect plugs (a: 2002-401), pluggable diode (b: 2002-800/1000-411) and LED modules (not shown here, 2002-800/1000-541) or fuse plugs (c: 2004-911) can alternatively be used here.

- ❶ Conductor sizes: 0.25 mm² ... 4 mm² "s + fst"; Push-in conductor sizes: 0.75 mm² ... 4 mm² "s" and 0.75 mm² ... 2.5 mm² "insulated ferrule, 12 mm"
- ❷ 500 V = rated voltage
6 kV = rated surge voltage
3 = pollution degree
(see Full Line Catalog, Volume 1, Section 14)
- ❸ Strip length, see packaging or instructions.
- ❹ Suitable for Ex i applications
- ❺ See application notes for:
Colored push-in type jumper bars, page 163
Vertical jumper, page 167



The **double-deck fuse disconnect terminal block with pivoting fuse holder (2002-2611, gray)** is compatible with disconnect, carrier, through and ground conductor terminal blocks. The fuse holder is also available with a blown fuse LED indicator. (e.g., 2002-2611/1000-541 for 12–30 V)



An **end plate for fuse terminal blocks (shown in orange, 2002-1092)** is used for additional protection, preventing the fuse shaft from being opened. The fuse cannot be replaced until disconnecting the fuse holder from the power supply.

2002 Series Accessories

Appropriate marking systems: WMB/
WMB Inline/Marking strips

End and intermediate plate, 1 mm thick			
	orange	2002-2692	100 (4x25)
	gray	2002-2691	100 (4x25)
Double-deck marker carrier,			
	pivoting		
	gray	2002-121	50 (2x25)
Insulation stop,			
	5 pcs/strip, 0.25 ... 0.5 mm ²		
	light gray	2002-171	200 (8x25)
Insulation stop,			
	5 pcs/strip, 0.75 ... 1 mm ²		
	dark gray	2002-172	200 (8x25)
Push-in type jumper bar, insulated,			
	❺ I _N 25 A, light gray		
	2-way	2002-402	200 (8x25)
	3-way	2002-403	200 (8x25)
	4-way	2002-404	200 (8x25)
	5-way	2002-405	100 (4x25)
	6-way	2002-406	100 (4x25)
	7-way	2002-407	100 (4x25)
	8-way	2002-408	100 (4x25)
	9-way	2002-409	100 (4x25)
	10-way	2002-410	100 (4x25)
Push-in type jumper bar, insulated,			
	❺ I _N 25 A, light gray		
	from 1 to 3	2002-433	200 (8x25)
	from 1 to 4	2002-434	200 (8x25)
	from 1 to 5	2002-435	100 (4x25)
	from 1 to 6	2002-436	100 (4x25)
	from 1 to 7	2002-437	100 (4x25)
	from 1 to 8	2002-438	100 (4x25)
	from 1 to 9	2002-439	100 (4x25)
	from 1 to 10	2002-440	100 (4x25)
Double-deck vertical jumper, insulated,			
	❺ I _N 24 A, light gray	2002-492	100 (4x25)
	orange	2002-492/000-012	
Adjacent jumper for continuous commoning, insulated,			
	❺ I _N 25 A, light gray		
	2-way	2002-400	100 (4x25)

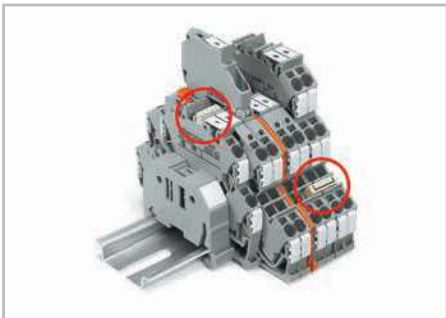

Same profile allows for commoning with TOPJOB® S double-deck terminal blocks (upper deck) and with triple-deck terminal blocks (lower deck).

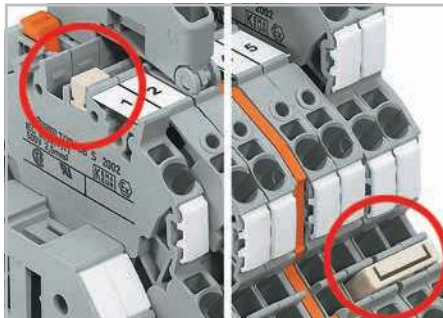

Left picture - Vertical jumper (2002-492)
Right picture - Push-in type jumper bar for 2002 Series

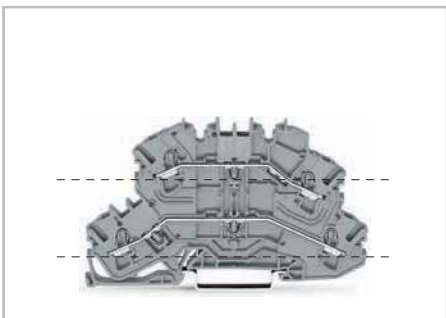

The **through terminal block (2002-2601)** features two independent current bars on both lower and upper deck, sharing the same profile as the disconnect terminal block. Commoning is also possible for these terminal blocks using the double-deck vertical jumper (2002-492).

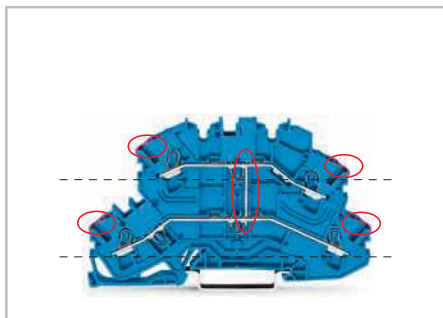

The **4-conductor through terminal block (2002-2609)** with internal commoning can be immediately identified via violet-colored conductor entry.

TOPJOB® S

Double-Deck Disconnect Terminal Blocks and Carrier Terminal Blocks 2.5 (4) mm², 2002 Series

PUSH-IN CAGE CLAMP®

0.25 ... 2.5 (4) mm ² ① 400 V/6 kV/3 ② I _N 16 A Terminal block width 5.2 mm / 0.205 in 10 ... 12 mm / 0.43 in ③	AWG 22 ... 12 300 V, 20 A ④	0.25 ... 2.5 (4) mm ² ① 400 V/6 kV/3 ② I _N 16 A Terminal block width 5.2 mm / 0.205 in 10 ... 12 mm / 0.43 in ③	AWG 22 ... 12 300 V, 20 A ④
---	--------------------------------	---	--------------------------------

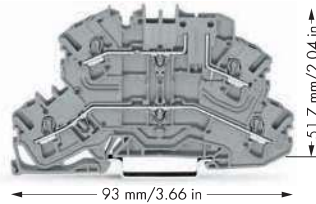

- ① Conductor sizes: 0.25 mm² ... 4 mm² "s + f-st"; Push-in conductor sizes: 0.75 mm² ... 4 mm² "s" and 0.75 mm² ... 2.5 mm² "insulated ferrule, 12 mm"
- ② 500 V = rated voltage
6 kV = rated surge voltage
3 = pollution degree
(see Full Line Catalog, Volume 1, Section 14)
- ③ Strip length, see packaging or instructions.
- ④ See application notes for:
Colored push-in type jumper bars, page 163
Vertical jumper, page 167

Item No.	Pack. Unit	Item No.	Pack. Unit		
Double-deck disconnect terminal block, with movable knife disconnect, gray housing		Double-deck carrier terminal block, upper deck carrier, gray housing			
○ L/L	2002-2671	50	○ L/L	2002-2661	50
○ N/L	2002-2672	50	○ N/L	2002-2662	50

2002 Series Accessories

Appropriate marking systems: WMB/
WMB Inline/Marking strips

End and intermediate plate, 1 mm thick			
	orange	2002-2692	100 (4x25)
	gray	2002-2691	100 (4x25)

Double-deck marker carrier, pivoting			
	gray	2002-121	50 (2x25)

Insulation stop, 5 pcs/strip, 0.25 ... 0.5 mm ²			
	light gray	2002-171	200 (8x25)

Insulation stop, 5 pcs/strip, 0.75 ... 1 mm ²			
	dark gray	2002-172	200 (8x25)

Push-in type jumper bar, insulated, I _N 25 A, light gray			
	2-way	2002-402	200 (8x25)
	3-way	2002-403	200 (8x25)
	4-way	2002-404	200 (8x25)
	5-way	2002-405	100 (4x25)
	6-way	2002-406	100 (4x25)
	7-way	2002-407	100 (4x25)
	8-way	2002-408	100 (4x25)
	9-way	2002-409	100 (4x25)
	10-way	2002-410	100 (4x25)

Push-in type jumper bar, insulated, I _N 25 A, light gray			
	from 1 to 3	2002-433	200 (8x25)
	from 1 to 4	2002-434	200 (8x25)
	from 1 to 5	2002-435	100 (4x25)
	from 1 to 6	2002-436	100 (4x25)
	from 1 to 7	2002-437	100 (4x25)
	from 1 to 8	2002-438	100 (4x25)
	from 1 to 9	2002-439	100 (4x25)
	from 1 to 10	2002-440	100 (4x25)

Double-deck vertical jumper, insulated, I _N 24 A			
	light gray	2002-492	100 (4x25)
	orange	2002-492/000-012	

Adjacent jumper for continuous commoning, insulated, I _N 25 A, light gray			
	2-way	2002-400	100 (4x25)

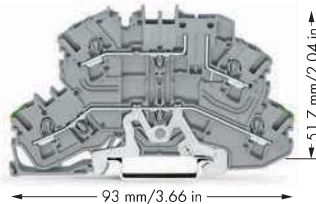

Item No.	Pack. Unit	
Double-deck carrier terminal block, upper deck carrier, gray housing		
○ PE/L	2002-2667	50

TOPJOB® S

Double-Deck Fuse Disconnect Terminal Blocks with Pivoting Fuse Holder 2.5 (4) mm², 2002 Series

PUSH-IN CAGE CLAMP®

0.25 ... 2.5 (4) mm ² ① 250 V/6 kV/3 ② I _N 6.3 A Terminal block width 6.2 mm / 0.244 in 10 ... 12 mm / 0.43 in ③	AWG 22 ... 12 300 V, 6.3 A	0.25 ... 2.5 (4) mm ² ① 250 V/6 kV/3 ② I _N 6.3 A Terminal block width 6.2 mm / 0.244 in 10 ... 12 mm / 0.43 in ③	AWG 22 ... 12 30 V, 6.3 A
--	-------------------------------	--	------------------------------

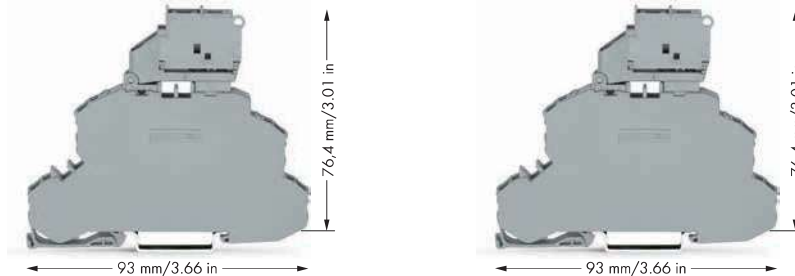

- ① Conductor sizes: 0.25 mm² ... 4 mm² "s + fst"; Push-in conductor sizes: 0.75 mm² ... 4 mm² "s" and 0.75 mm² ... 2.5 mm² "insulated ferrule, 1.2 mm"
- ② 250 V = rated voltage
6 kV = rated surge voltage
3 = pollution degree
(see Full Line Catalog, Volume 1, Section 14)
- ③ Strip length, see packaging or instructions.
- ④ See application notes for:
Vertical jumper, page 167
- ⑤ Protective warning marker and insulation stop must be applied individually.
- ⑥ Due to the 6.2 mm width of fuse terminal blocks with pivoting fuse holder, 2004 Series jumpers must be used.

Item No.	Pack. Unit	Item No.	Pack. Unit
Double-deck fuse disconnect terminal block with pivoting fuse holder, Through/fuse terminal block, for miniature fuses 5 x 20 mm, without blown fuse indication Nominal voltage and current are given by the fuse.		Double-deck fuse disconnect terminal block with pivoting fuse holder, Through/fuse terminal block, for miniature fuses 5 x 20 mm, with blown fuse indication by LED, gray Nominal voltage and current are given by the LED or fuse. Leakage current in case of blown fuse: LED 2mA	
● L/L	2002-2611	25	● 12 ... 30 V
● N/L	2002-2612	25	● 30 ... 65 V
			● 230 V
			2002-2611/1000-541 25
			2002-2611/1000-542 25
			2002-2611/1000-836 25

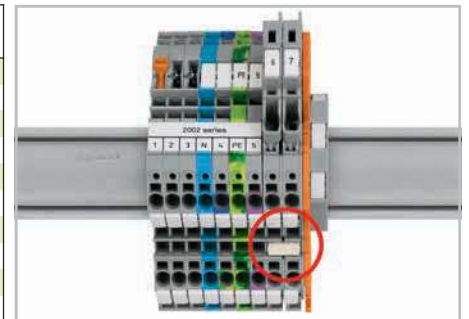

A spacer plate is supplied with all 6.2 mm wide fuse terminal blocks.
Due to the 6.2 mm width of fuse terminal blocks with pivoting fuse holder, 2004 Series jumpers must be used.

2002 Series Accessories

Appropriate marking systems: WMB/WMB Inline/Marking strips

End and intermediate plate, 1 mm thick orange 2002-2692 100 (4x25) gray 2002-2691 100 (4x25)	End plate for fuse terminal blocks, 2 mm thick orange 2002-1092 100 (4x25) gray 2002-1091 100 (4x25)
Push-in type jumper bar, insulated, ④ ⑥ I _N 32 A, light gray 2-way 2004-402 200 (8x25) 3-way 2004-403 200 (8x25) 4-way 2004-404 100 (4x25) 5-way 2004-405 100 (4x25) 6-way 2004-406 100 (4x25) 7-way 2004-407 100 (4x25) 8-way 2004-408 100 (4x25) 9-way 2004-409 100 (4x25) 10-way 2004-410 100 (4x25)	Insulation stop, ⑤ 5 pcs/strip, 0.25 ... 0.5 mm ² light gray 2002-171 200 (8x25) Insulation stop, 5 pcs/strip, 0.75 ... 1 mm ² dark gray 2002-172 200 (8x25) Protective warning marker, ⑤ with high-voltage symbol, black, for 5 terminal blocks yellow 2002-115 100 (4x25)
Push-in type jumper bar, insulated, I _N 32 A, light gray from 1 to 3 2004-433 200 (8x25) from 1 to 4 2004-434 200 (8x25) from 1 to 5 2004-435 100 (4x25) from 1 to 6 2004-436 100 (4x25) from 1 to 7 2004-437 100 (4x25) from 1 to 8 2004-438 100 (4x25) from 1 to 9 2004-439 100 (4x25) from 1 to 10 2004-440 100 (4x25)	Test plug, with 500 mm cable, 2 mm Ø red 210-136 50 Test plug, with 500 mm cable, 2.3 mm Ø yellow 210-137 50 Marking strip, plain, 11 mm wide, 50 m roll white 2009-110 1
Double-deck vertical jumper, insulated, ④ I _N 24 A light gray 2002-492 100 (4x25) orange 2002-492/000-012	

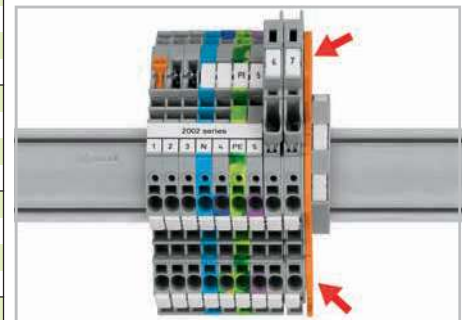

Additionally, an end plate for fuse terminal blocks (e.g., 2002-1092, orange) must be used at the end of an assembly or if there is no adjacent fuse terminal block.

TOPJOB® S

Triple-Deck Terminal Blocks 2.5 (4) mm²

2002 Series

0.25 ... 2.5 (4) mm ² ① 500 V/6 kV/3 ② I _N 24 A (28 A)	AWG 22 ... 12 600 V, 20 A ③ 600 V, 20 A ④	0.25 ... 2.5 (4) mm ² ① 500 V/6 kV/3 ② I _N 24 A (28 A)	AWG 22 ... 12 600 V, 20 A ③ 600 V, 20 A ④	0.25 ... 2.5 (4) mm ² ① 500 V/6 kV/3 ② I _N 24 A (28 A)	AWG 22 ... 12 600 V, 20 A ③ 600 V, 20 A ④
Terminal block width 5.2 mm / 0.205 in. 10 ... 12 mm / 0.43 in. ③		Terminal block width 5.2 mm / 0.205 in. 10 ... 12 mm / 0.43 in. ③		Terminal block width 5.2 mm / 0.205 in. 10 ... 12 mm / 0.43 in. ③	

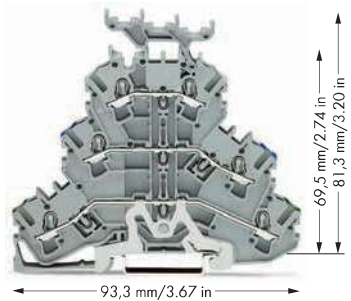
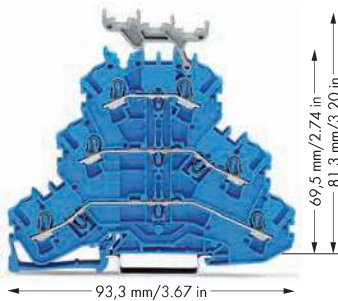
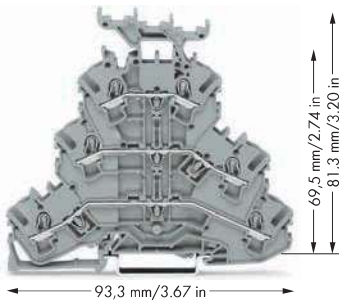

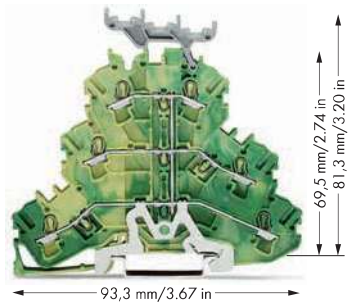
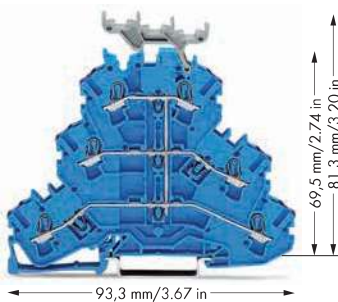
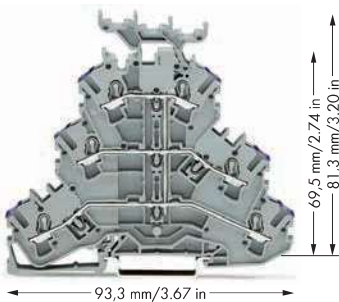

Item No.	Pack. Unit	Item No.	Pack. Unit	Item No.	Pack. Unit
Through/through/through terminal block, with marker carrier, gray housing		Through/through/through terminal block, with marker carrier, blue housing		Ground conductor/through/through terminal block, with marker carrier, gray housing	
○ L/L/L ⑤	2002-3231 ⑤ 50	● N/N/N ⑤	2002-3234 ④ ⑤ 50	○ PE/N/L ⑤	2002-3247 ⑤ 50
○ L/L/N ⑤	2002-3233 ⑤ 50			○ PE/L/L ⑤	2002-3257 ⑤ 50
Through/through/through terminal block, without marker carrier, gray housing		Through/through/through terminal block, without marker carrier, blue housing		Ground conductor/through/through terminal block, without marker carrier, gray housing	
○ L/L/L ⑤	2002-3201 ⑤ 50	● N/N/N ⑤	2002-3204 ④ ⑤ 50	○ PE/N/L ⑤	2002-3217 ⑤ 50
○ L/L/N ⑤	2002-3203 ⑤ 50			○ PE/L/L ⑤	2002-3227 ⑤ 50
Other terminal blocks with the same profile:					
Diode	2002-3211/1000-410	Page 100			
LED	2002-3221/1000-434	Page 100			



Item No.	Pack. Unit	Item No.	Pack. Unit	Item No.	Pack. Unit
6-conductor through terminal block, with marker carrier, internal commoning, conductor entry position colored in violet, gray housing		6-conductor through terminal block, with marker carrier, internal commoning, conductor entry position colored in violet, blue housing		6-conductor ground terminal block, with marker carrier, internal commoning, green-yellow housing	
○ L ⑤	2002-3238 ⑤ 50	● N ⑤	2002-3239 ④ ⑤ 50	● PE ⑤	2002-3237 ⑤ 50
6-conductor through terminal block, without marker carrier, internal commoning, conductor entry position colored in violet, gray housing		6-conductor through terminal block, without marker carrier, internal commoning, conductor entry position colored in violet, blue housing		6-conductor ground terminal block, without marker carrier, internal commoning, green-yellow housing	
○ L ⑤	2002-3208 ⑤ 50	● N ⑤	2002-3209 ④ ⑤ 50	● PE ⑤	2002-3207 ⑤ 50

TOPJOB® S

Quadruple-Deck, Rail-Mounted Terminal Blocks or Rail-Mounted Terminal Blocks for Wiring of Electric Motors, 2002 Series



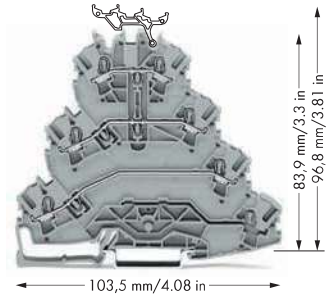
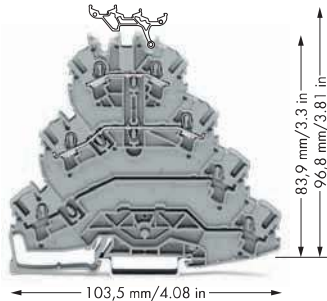
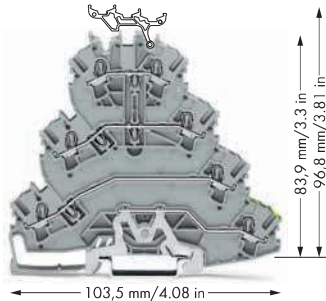







0.25 ... 2.5 (4) mm ² ① AWG 22 ... 12 800 V/8 kV/3 ② I _N 20 A (25 A) Terminal block width 5.2 mm / 0.205 in.  10 ... 12 mm / 0.43 in. ③	0.25 ... 2.5 (4) mm ² ① AWG 22 ... 12 800 V/8 kV/3 ② I _N 20 A (25 A) Terminal block width 5.2 mm / 0.205 in.  10 ... 12 mm / 0.43 in. ③	0.25 ... 2.5 (4) mm ² ① AWG 22 ... 12 800 V/8 kV/3 ② I _N 20 A (25 A) Terminal block width 5.2 mm / 0.205 in.  10 ... 12 mm / 0.43 in. ③
---	--	--



Item No.	Pack. Unit	Item No.	Pack. Unit	Item No.	Pack. Unit
Quadruple-deck, rail-mounted terminal block or Rail-mounted terminal block for wiring of electric motors, without marker carrier, gray ○ L1 - L2 - L3 - PE 2002-4127	25	Quadruple-deck, rail-mounted terminal block or Rail-mounted terminal block for wiring of electric motors, without marker carrier, gray ○ L1 - L2 2002-4111	25	Quadruple-deck, rail-mounted terminal block or Rail-mounted terminal block for wiring of electric motors, without marker carrier, gray ○ L1 - L2 - L3 2002-4101	25
Quadruple-deck, rail-mounted terminal block or Rail-mounted terminal block for wiring of electric motors, with marker carrier, gray ○ L1 - L2 - L3 - PE 2002-4157	25	Quadruple-deck, rail-mounted terminal block or Rail-mounted terminal block for wiring of electric motors, with marker carrier, gray ○ L1 - L2 2002-4141	25	Quadruple-deck, rail-mounted terminal block or Rail-mounted terminal block for wiring of electric motors, with marker carrier, gray ○ L1 - L2 - L3 2002-4131	25

2002 Series Accessories

Appropriate marking systems: WMB/WMB Inline/Marking strips

End and intermediate plate , 1 mm thick  orange 2002-4192 100 (4x25) gray 2002-4191 100 (4x25)	Protective warning marker , with high-voltage symbol, black, for 5 terminal blocks  yellow 2002-115 100 (4x25)	Staggered jumper , ④ insulated, I _N 25 A, light gray  2-way 2002-472 100 (4x25) 3-way 2002-473 100 (4x25) 4-way 2002-474 100 (4x25) 5-way 2002-475 50 (2x25) 6-way 2002-476 50 (2x25) 7-way 2002-477 50 (2x25) 8-way 2002-478 50 (2x25) 9-way 2002-479 50 (2x25) 10-way 2002-480 50 (2x25) 11-way 2002-481 50 (2x25) 12-way 2002-482 50 (2x25)
Insulation stop ,  5 pcs/strip, 0.25 ... 0.5 mm ² light gray 2002-171 200 (8x25)	Lockout cap ,  for conductor entry hole and operating slot orange 2002-192 25 gray 2002-191 25 blue 2002-194 25	Push-in type wire jumper , ④ insulated, I _N 18 A, wire size 1.5 mm ²  L = 60 mm 2009-412 100 (10x10) L = 110 mm 2009-414 100 (10x10) L = 250 mm 2009-416 100 (10x10)
Insulation stop ,  5 pcs/strip, 0.75 ... 1 mm ² dark gray 2002-172 200 (8x25)	Push-in type jumper bar , insulated, ④ I _N 25 A, light gray  2-way 2002-402 200 (8x25) 3-way 2002-403 200 (8x25) 4-way 2002-404 200 (8x25) 5-way 2002-405 100 (4x25) 6-way 2002-406 100 (4x25) 7-way 2002-407 100 (4x25) 8-way 2002-408 100 (4x25) 9-way 2002-409 100 (4x25) 10-way 2002-410 100 (4x25)	WMB Inline , plain,  stretchable 5 ... 5.2 mm, 1,500 WMB markers, 5 mm, on roll white 2009-115 1
Star point jumper , insulated, ④ I _N = I _N terminal block, light gray 1-3-5 2002-405/011-000 100 (4x25)	Adjacent jumper for continuous commoning , insulated, ④ I _N 25 A, light gray 2-way 2002-400 100 (4x25)	Marking strip , plain,  11 mm wide, 50 m roll white 2009-110 1
Delta jumper , insulated, ④ I _N = I _N terminal block, light gray 1-2 3-4 5-6 2002-406/020-000 100 (4x25)	Triple-deck marker carrier ,  pivoting gray 2002-131 50 (2x25)	

Approvals see www.wago.com

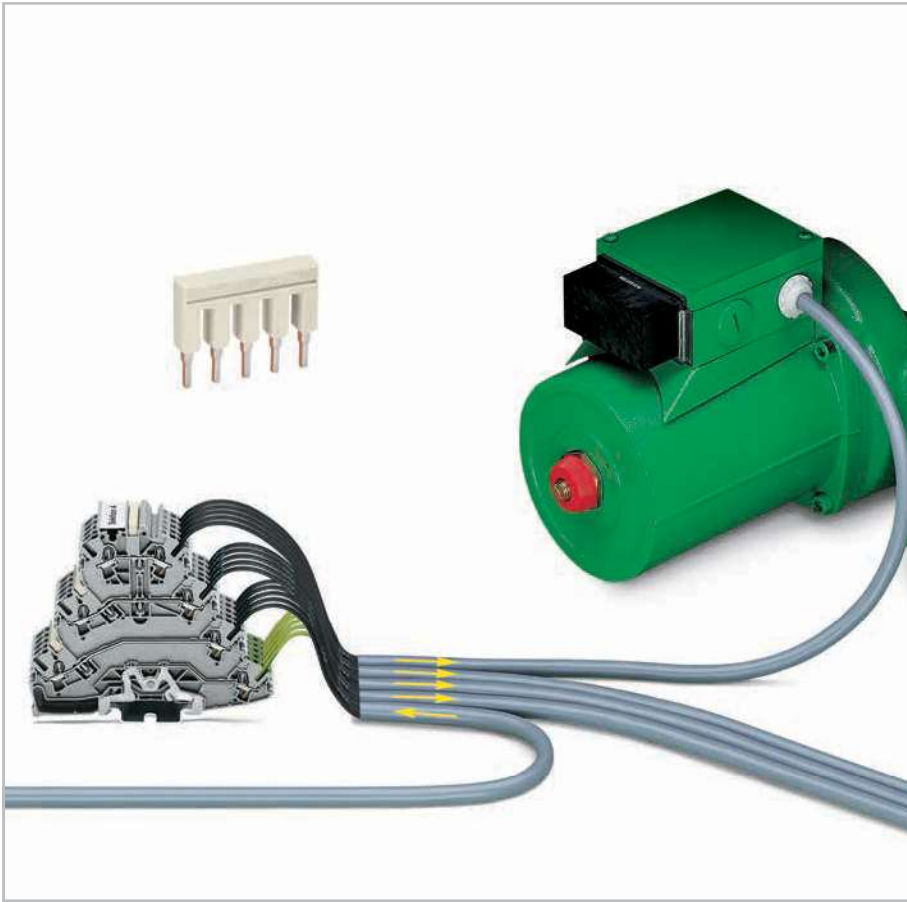

- ❶ Conductor sizes: 0.25 mm² ... 4 mm² "s + f-st";
Push-in conductor sizes: 0.75 mm² ... 4 mm² "s"
and 0.75 mm² ... 2.5 mm²
"insulated ferrule, 12 mm"
- ❷ 800 V = rated voltage
8 kV = rated surge voltage
3 = pollution degree
(see Full Line Catalog, Volume 1, Section 14)
- ❸ Strip length, see packaging or instructions.
- ❹ See application notes for:
Colored push-in type jumper bars, page 163
Staggered jumper, page 166
Delta jumper, page 165
Star point jumper, page 165
Adjacent jumper for continuous commoning,
page 163
Push-in type wire jumper, page 164
TOPJOB® S connector, page 158
TOPJOB® S L-type test plug module, page 162
Marker carrier, page 179

In addition to rail-mounted terminal blocks for electric motor wiring, new versions are now available.

- Terminal block **without** ground contact and only 2 potentials.

Especially for additional functions such as engine brakes or temperature probes. Having the same shape, this type can be put next to the appropriate terminal block for electric motor wiring without using intermediate plates.

That makes the rail assembly clearer and wiring is easier. This also prevents wiring errors as no conductor entry is unused.

- Terminal block **without** ground contact and with only 3 potentials.

Clearly designated clamping units is the primary advantage to this terminal block design. When using devices with protective insulation for example, there are no open ground clamping units that could create confusion.



Lockout cap for conductor entry hole and operating slot

Locking out conductor entry holes and operating slots to create spacer housings for rail-mounted terminal blocks for electric motor wiring.



Compact design:
3 phases and ground conductor in one terminal block.



Marking clamping units with WMB Multi marking system.
Group marking with marking strips.

FUNCTION TERMINAL BLOCKS

Disconnection – Fuse Protection

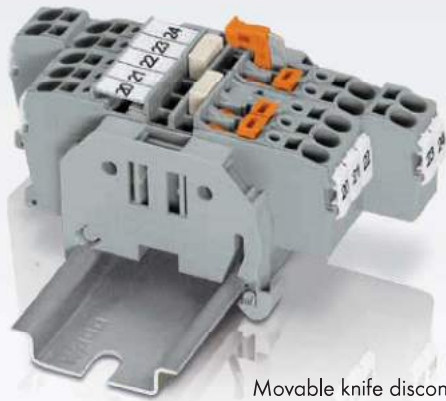

Movable knife disconnects clearly indicate the circuit state.

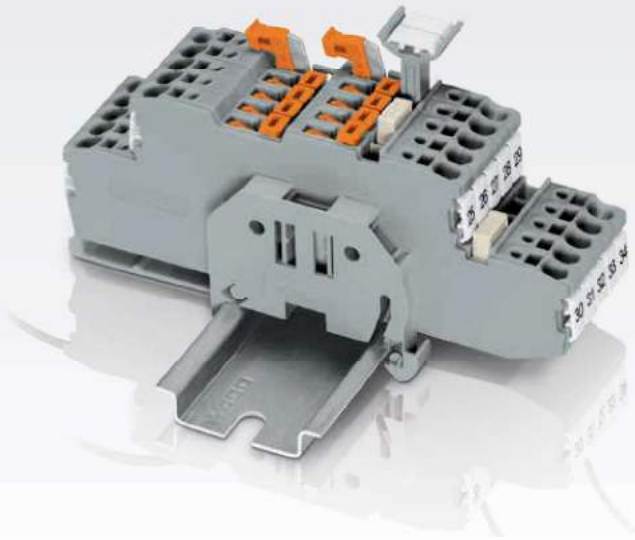

2-, 3- and 4-Conductor Disconnect Terminal Blocks

- Feature three alternative disconnect options: via movable knife disconnect and additional mechanical interlock or via disconnect plug
- The same shape as corresponding through terminal blocks maintain uniformity and provide a clear overview

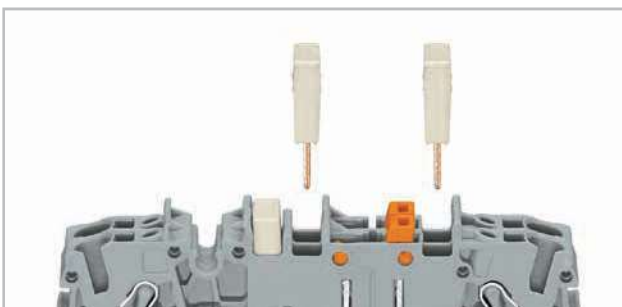

An additional jumper slot is located behind the knife disconnect: Commoning options in front of or behind the knife disconnect, depending on the power supply direction.

Double-Deck, Double-Disconnect Terminal Blocks

- Two potential-free disconnect terminal blocks are housed on two levels
- Saves space without compromising usability
- The knife disconnects are located between the conductors, always making them visible to the operator

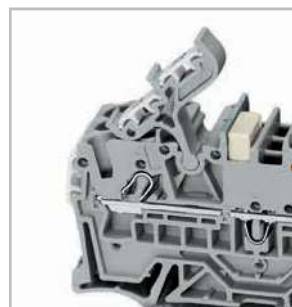

Pivoting marker carriers provide an additional marking location.



Variant: One disconnect and one through terminal block are accommodated on two levels in a terminal block that is just 5.2 mm wide.

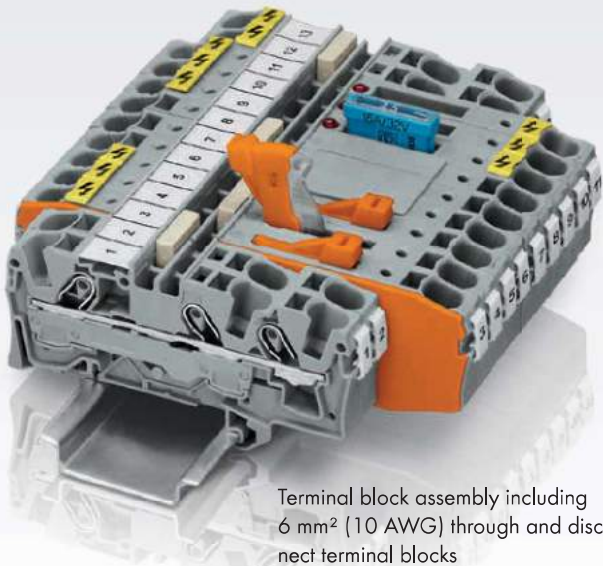

Terminal block assembly including 6 mm² (10 AWG) through and disconnect terminal blocks

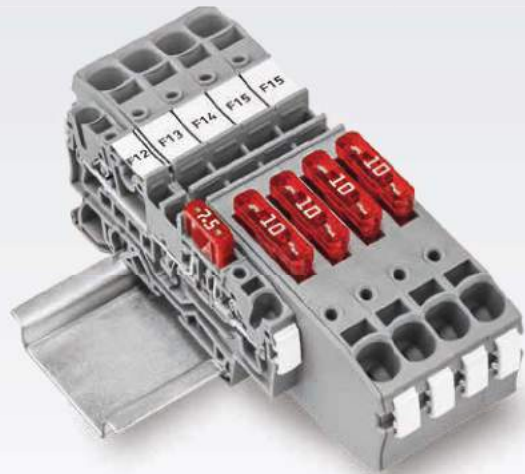

Fuse terminal blocks for DIN 72581-3f blade-style fuses

Disconnect/Ground Conductor Disconnect Terminal Blocks

- Perfect for high-voltage or renewable energy applications
- Ground conductor disconnect terminal blocks provide service-friendly testing for potential ground faults
- Available for conductors ranging in size from 0.5 mm² ... 10 mm² (20 ... 8 AWG)

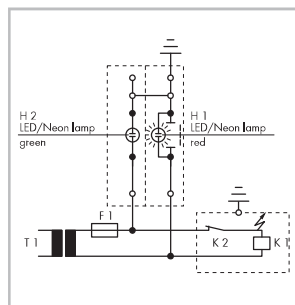
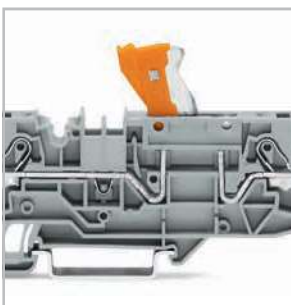

Test position – grounding: slide link open, auxiliary circuit not grounded, red LED/neon lamp lights



Ground conductor disconnect terminal block – top view

Fuse Terminal Blocks

- Protect electrical circuits against short-circuiting
- Suitable for miniature metric fuses or blade-style fuses
- Can be assembled into strips and easily replaced if required



Pivoting the fuse holder open to the locked position. Fuse terminal blocks for miniature metric fuses rated at 2.5 mm² (12 AWG) and 6 mm² (8 AWG)

FUNCTION TERMINAL BLOCKS

Integrated or Pluggable Diodes

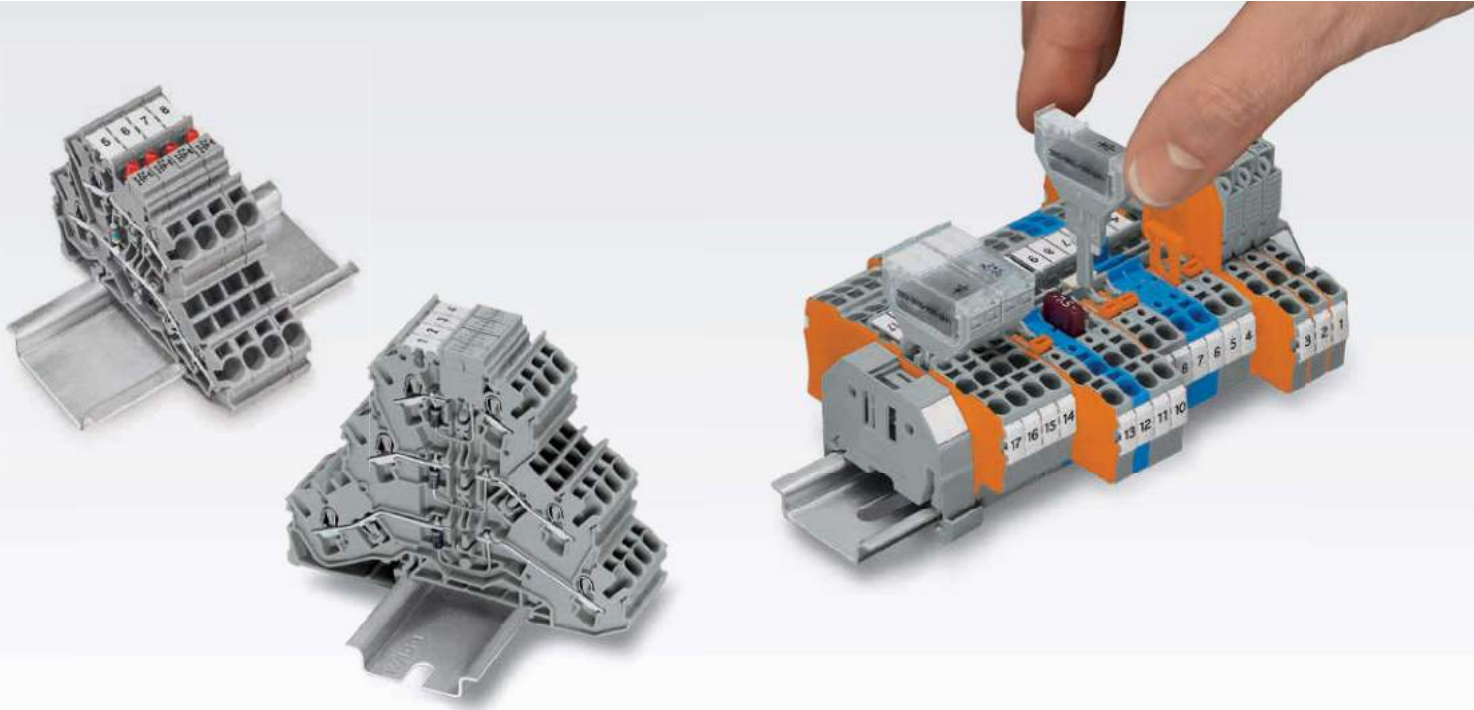

Double-Deck and Triple-Deck Diode Terminal Blocks

- Ideal for custom diode circuits, such as lamp test and collective fault signal circuits
- LED terminal blocks enable monitoring units to be designed (e.g., control and operating circuits)
- Push-in type jumper bars permit custom circuit design

Pluggable Diode and LED Modules

- Component plugs can either be pre-assembled, or the components (e.g., diodes, resistors) can be assembled by the user via solder-free connection
- Available in 5.2 mm or 10.4 mm width for carrier terminal blocks or for use in a jumper slot



LED terminal blocks with a red LED



Marking via WMB Multi markers and marking strips



Test option available

Current Transformer and Electric Motor Wiring Terminal Blocks

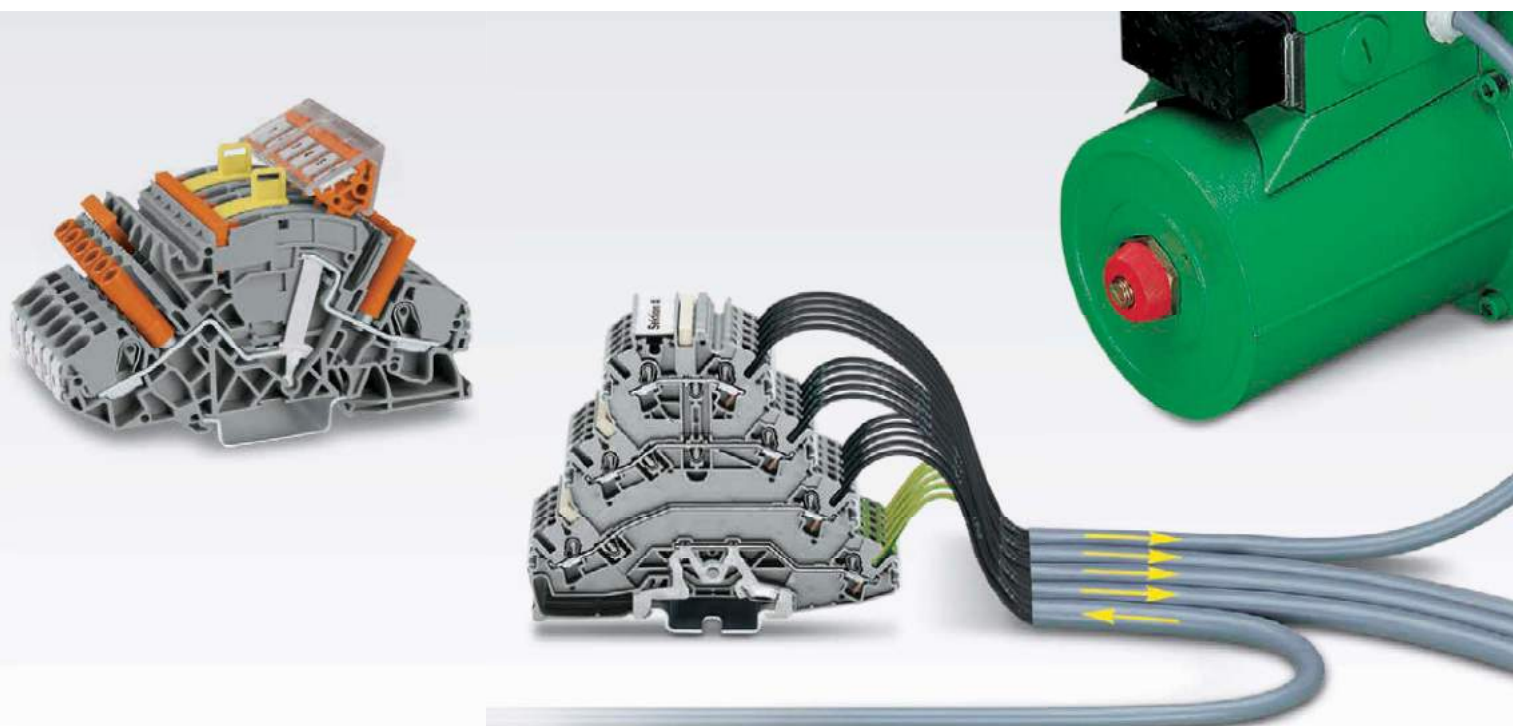

Current Transformer Terminal Blocks

- Safe, automatic short-circuiting
- Easily test current transformer circuits
- Intuitive orange disconnect links simplify operation
- Directly identify the circuit state via an open, touch-proof design
- Can be clearly labeled



Additional commoning option on the transformer side

Rail-Mounted Terminal Blocks for Electric Motor Wiring

- Quadruple-deck, rail-mounted terminal blocks for electric motor wiring
- Three phases and one ground conductor in a single terminal block
- Specialty versions featuring two or three potentials without a ground contact are also available



Identify clamping units via WMB markers and groups via marking strips.

TOPJOB® S

Double-Deck Disconnect Terminal Blocks for Test and Measurement

2.5 (4) mm², 2002 Series

0.25 ... 2.5 (4) mm ² ① 400 V/6 kV/3 ② I _N 16 A Terminal block width 5.2 mm / 0.205 in. 10 ... 12 mm / 0.43 in. ③	AWG 22 ... 12 300 V, 15 A ④ 300 V, 15 A ⑤	0.25 ... 2.5 (4) mm ² ① 400 V/6 kV/3 ② I _N 16 A Terminal block width 5.2 mm / 0.205 in. 10 ... 12 mm / 0.43 in. ③	AWG 22 ... 12 300 V, 15 A ④ 300 V, 15 A ⑤	0.25 ... 2.5 (4) mm ² ① 400 V/6 kV/3 ② I _N 16 A Terminal block width 5.2 mm / 0.205 in. 10 ... 12 mm / 0.43 in. ③	AWG 22 ... 12 300 V, 15 A ④ 300 V, 15 A ⑤
---	---	---	---	---	---

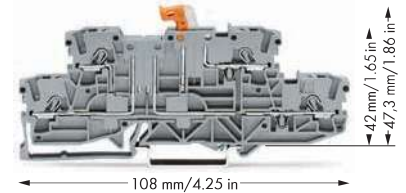
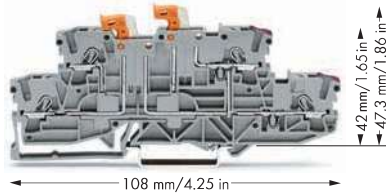
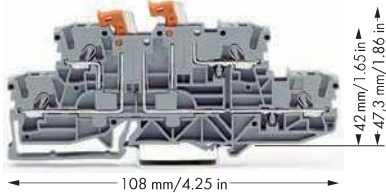

Item No.	Pack. Unit	Item No.	Pack. Unit	Item No.	Pack. Unit
Double-deck, double-disconnect terminal block, with 2 pivoting knife disconnects, gray housing		Double-deck, double-disconnect terminal block, with 2 pivoting knife disconnects, lower and upper decks internally commoned on right side and with violet marking, gray housing		Double-deck disconnect terminal block, with pivoting knife disconnect, same profile as double-deck, double-disconnect terminal block, gray housing	
○ L/L 2002-2951	50	○ L/L 2002-2958	50	○ L/L 2002-2971	50
○ N/L 2002-2952	50			○ N/L 2002-2972	50
Double-deck, double-disconnect terminal block, with 2 pivoting knife disconnects, blue housing		Double-deck, double-disconnect terminal block, with 2 pivoting knife disconnects, lower and upper decks internally commoned on right side and with violet marking, blue housing		Double-deck disconnect terminal block, with pivoting knife disconnect, same profile as double-deck, double-disconnect terminal block, blue housing	
● N/N 2002-2954	50	● N/N 2002-2959	50	● N/N 2002-2974	50

2002 Series Accessories

Appropriate marking systems: WMB/Marking strips

End and intermediate plate, 1 mm thick orange 2002-2992 100 (4x25) gray 2002-2991 100 (4x25)	Push-in type jumper bar, insulated, I_N 25 A, light gray from 1 to 3 2002-433 200 (8x25) from 1 to 4 2002-434 200 (8x25) from 1 to 5 2002-435 100 (4x25) from 1 to 6 2002-436 100 (4x25) from 1 to 7 2002-437 100 (4x25) from 1 to 8 2002-438 100 (4x25) from 1 to 9 2002-439 100 (4x25) from 1 to 10 2002-440 100 (4x25)	Protective warning marker, with high-voltage symbol, black, for 5 terminal blocks yellow 2002-115 100 (4x25)
Insulation stop, 5 pcs/strip, 0.25 ... 0.5 mm², light gray 2002-171 200 (8x25)		Modular TOPJOB® S connector, can be snapped together, for jumper contact slot gray 2002-511 100 (4x25)
Insulation stop, 5 pcs/strip, 0.75 ... 1 mm², dark gray 2002-172 200 (8x25)		Spacer module, can be snapped together, e.g., for bridging commoned terminal blocks gray 2002-549 100 (4x25)
Push-in type jumper bar, insulated, I_N 25 A, light gray 2-way 2002-402 200 (8x25) 3-way 2002-403 200 (8x25) 4-way 2002-404 200 (8x25) 5-way 2002-405 100 (4x25) 6-way 2002-406 100 (4x25) 7-way 2002-407 100 (4x25) 8-way 2002-408 100 (4x25) 9-way 2002-409 100 (4x25) 10-way 2002-410 100 (4x25)	Staggered jumper, insulated, I_N 25 A, light gray 2-way 2002-472 100 (4x25) 3-way 2002-473 100 (4x25) 4-way 2002-474 100 (4x25) 5-way 2002-475 50 (2x25) 6-way 2002-476 50 (2x25) 7-way 2002-477 50 (2x25) 8-way 2002-478 50 (2x25) 9-way 2002-479 50 (2x25) 10-way 2002-480 50 (2x25) 11-way 2002-481 50 (2x25) 12-way 2002-482 50 (2x25)	End plate, for modular TOPJOB® S connectors, 1.5 mm thick gray 2002-541 100 (4x25)
Push-in type wire jumper, insulated, I_N 18 A, wire size 1.5 mm² L = 60 mm 2009-412 100 (10x10) L = 110 mm 2009-414 100 (10x10) L = 250 mm 2009-416 100 (10x10)	Adjacent jumper for continuous commoning, insulated, I_N 25 A, light gray 2-way 2002-400 100 (4x25)	Test plug, with 500 mm cable, 2 mm Ø red 210-136 50
		Test plug adapter, for 4 mm Ø test plug gray 2009-174 100 (4x25)
		Testing tap, for max. 2.5 mm² gray 2009-182 100 (4x25)
		Banana plug, for socket 4 mm Ø, color mixed 215-111 50

Double-Deck Disconnect Terminal Blocks with Pivoting Knife Disconnect

PUSH-IN CAGE CLAMP®



Terminal block assembly



Group marker carrier accommodated in jumper contact slot.

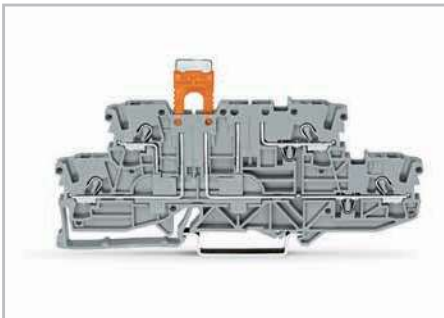



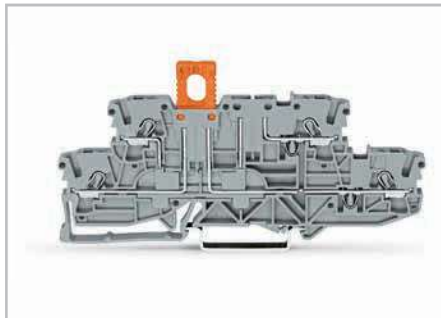



Carrier terminal block (2002-2941) with disconnect plug (2002-401) in parked position.



Carrier terminal block (2002-2941) with disconnect plug (2002-401) in operating position.

- ❶ Conductor sizes: 0.25 mm² ... 4 mm² "s + f-st";
Push-in conductor sizes: 0.75 mm² ... 4 mm² "s"
and 0.75 mm² ... 2.5 mm²
"insulated ferrules, 12 mm"
- ❷ 400 V = rated voltage
6 kV = rated surge voltage
3 = pollution degree
(see Full Line Catalog, Volume 1, Section 14)
- ❸ Strip length, see packaging or instructions.
- ❹ See application notes for:
Colored push-in type jumper bars, page 163
Staggered jumper, page 166
Delta jumper, page 165
Star point jumper, page 165
Adjacent jumper for continuous commoning, page 163
Push-in type wire jumper, page 164
TOPJOB® S connector, page 158
TOPJOB® S L-type test plug module, page 162

Accessories

WMB Multi marking system,		
	10 strips with 10 markers per card, stretchable 5 ... 5.2 mm plain	793-5501 5
WMB Multi marking system, plain,		
	10 strips with 10 markers per card, stretchable 5 ... 5.2 mm	
yellow	793-5501/000-002	
red	793-5501/000-005	
blue	793-5501/000-006	
gray	793-5501/000-007	
orange	793-5501/000-012	
light green	793-5501/000-017	
green	793-5501/000-023	
violet	793-5501/000-024	5
WMB Inline, plain,		
	stretchable 5 ... 5.2 mm, 1,500 WMB markers, 5 mm, on roll white	2009-115 1
TOPJOB® S group marker carrier,		
	snap-on type for jumper slot, 5 mm wide	
gray	2009-191	50 (2x25)
Screwless end stop,		
	for DIN 35 rail, 6 mm wide	
gray	249-116	100 (4x25)
Screwless end stop,		
	for DIN 35 rail, 10 mm wide	
gray	249-117	50 (2x25)

TOPJOB® S

Disconnect Terminal Blocks for Test and Measurement, Through Terminal Blocks of Same Profile 2.5 (4) mm², 2002 Series

0.25 ... 2.5 (4) mm ² ① 400 V/6 kV/3 ② I _N 16 A Terminal block width 5.2 mm / 0.205 in. 10 ... 12 mm / 0.43 in. ③	AWG 22 ... 12 300 V, 15 A ④ 300 V, 10 A ⑤	0.25 ... 2.5 (4) mm ² ① 400 V/6 kV/3 ② I _N 16 A Terminal block width 5.2 mm / 0.205 in. 10 ... 12 mm / 0.43 in. ③	AWG 22 ... 12 300 V, 15 A ④	0.25 ... 2.5 (4) mm ² ① 400 V/6 kV/3 ② I _N 16 A Terminal block width 5.2 mm / 0.205 in. 10 ... 12 mm / 0.43 in. ③	AWG 22 ... 12 300 V, 15 A ④ 300 V, 10 A ⑤
---	---	---	--------------------------------	---	---

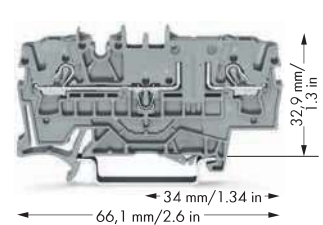
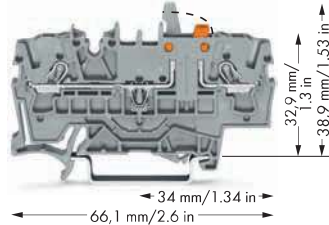
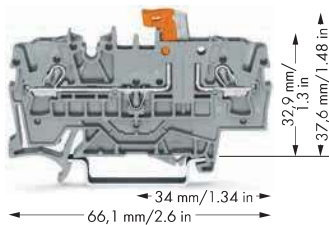

Item No.	Pack. Unit	Item No.	Pack. Unit	Item No.	Pack. Unit
2-conductor disconnect terminal block for test and measurement, with test point, orange disconnect link		2-conductor disconnect terminal block for test and measurement with mechanical interlock, with test point, orange disconnect link		2-conductor through terminal block, with test point, same profile as 2-conductor disconnect terminal block	
gray 2002-1671	50	gray 2002-1671/401-000	50	gray 2002-1601	50
blue 2002-1674	50	blue 2002-1674/401-000	50	blue 2002-1604	50
orange 2002-1672	50	orange 2002-1672/401-000	50	orange 2002-1602	50
				Other terminal blocks with the same profile:	
				Carrier 2002-1661	Page 88
				Fuse 2002-1681	Page 62

2002 Series Accessories

Appropriate marking systems: WMB/WMB Inline/Marking strips

End and intermediate plate, 1 mm thick orange 2002-1692 100 (4x25) gray 2002-1691 100 (4x25)	Protective warning marker, with high-voltage symbol, black, for 5 terminal blocks yellow 2002-115 100 (4x25)	Customized staggered jumper, insulated, I_N 25 A, light gray 1-3 2002-473/011-000 100 (4x25) 1-3-5 2002-475/011-000 1-3-5-7 2002-477/011-000 1-3-5-7-9 2002-479/011-000 1-3-5-7-9-11 2002-481/011-000 50 (2x25)
Insulation stop, 5 pcs/strip, 0.25 ... 0.5 mm² light gray 2002-171 200 (8x25)	Push-in type jumper bar, insulated, I_N 25 A, light gray from 1 to 3 2002-433 200 (8x25) from 1 to 4 2002-434 200 (8x25) from 1 to 5 2002-435 100 (4x25) from 1 to 6 2002-436 100 (4x25) from 1 to 7 2002-437 100 (4x25) from 1 to 8 2002-438 100 (4x25) from 1 to 9 2002-439 100 (4x25) from 1 to 10 2002-440 100 (4x25)	Adjacent jumper for continuous commoning, insulated, I_N 25 A, light gray 2-way 2002-400 100 (4x25)
Insulation stop, 5 pcs/strip, 0.75 ... 1 mm² dark gray 2002-172 200 (8x25)	Staggered jumper, insulated, I_N 25 A, light gray 2-way 2002-472 100 (4x25) 3-way 2002-473 100 (4x25) 4-way 2002-474 100 (4x25) 5-way 2002-475 50 (2x25) 6-way 2002-476 50 (2x25) 7-way 2002-477 50 (2x25) 8-way 2002-478 50 (2x25) 9-way 2002-479 50 (2x25) 10-way 2002-480 50 (2x25) 11-way 2002-481 50 (2x25) 12-way 2002-482 50 (2x25)	Modular TOPJOB® S connector, can be snapped together, for jumper contact slot, gray 2002-511 100 (4x25)
Push-in type jumper bar, insulated, I_N 25 A, light gray 2-way 2002-402 200 (8x25) 3-way 2002-403 200 (8x25) 4-way 2002-404 200 (8x25) 5-way 2002-405 100 (4x25) 6-way 2002-406 100 (4x25) 7-way 2002-407 100 (4x25) 8-way 2002-408 100 (4x25) 9-way 2002-409 100 (4x25) 10-way 2002-410 100 (4x25)		Spacer module, can be snapped together, e.g., for bridging commoned terminal blocks, gray 2002-549 100 (4x25)
Push-in type wire jumper, insulated, I_N 18 A, wire size 1.5 mm² L = 60 mm 2009-412 100 (10x10) L = 110 mm 2009-414 100 (10x10) L = 250 mm 2009-416 100 (10x10)		End plate, for modular TOPJOB® S connectors, 1.5 mm thick, gray 2002-541 100 (4x25)
		TOPJOB® S L-test plug module, can be snapped together, gray 2002-611 100 (4x25)

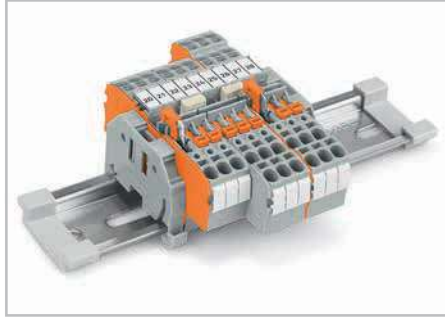

One center and two side marker slots for WMB markers or marking strips. Dual jumper slots, in the same position as the 2002 Series terminal blocks. Commoning options in front of or behind the knife disconnect, depending on the power supply direction.

- 1 Conductor sizes: 0.25 mm² ... 4 mm² "s + f-st";
Push-in conductor sizes: 0.75 mm² ... 4 mm² "s"
and 0.75 mm² ... 2.5 mm²
"insulated ferrules, 12 mm"
- 2 400 V = rated voltage
6 kV = rated surge voltage
3 = pollution degree
(see Full Line Catalog, Volume 1, Section 14)
- 3 Strip length, see packaging or instructions.
- 4 See application notes for:
Colored push-in type jumper bars, page 163
Staggered jumper, page 166
Adjacent jumper for continuous commoning, page 163
Push-in type wire jumper, page 164
TOPJOB® S connector, page 158
TOPJOB® S L-type test plug module, page 162

Accessories

Test plug adapter,



for 4 mm Ø test plug
gray **2009-174** 100 (4x25)

Testing tap,



for max. 2.5 mm²
gray **2009-182** 100 (4x25)

Banana plug,



for socket 4 mm Ø,
color mixed
215-111 50

Double-deck marker carrier,



pivoting
gray **2002-121** 50 (2x25)

WMB Multi marking system,



10 strips with 10 markers per card,
stretchable 5 ... 5.2 mm
plain **793-5501** 5

WMB Inline, plain,



stretchable 5 ... 5.2 mm,
1,500 WMB markers, 5 mm, on roll
white **2009-115** 1

Marking strip, plain,



11 mm wide,
50 m roll
white **2009-110** 1

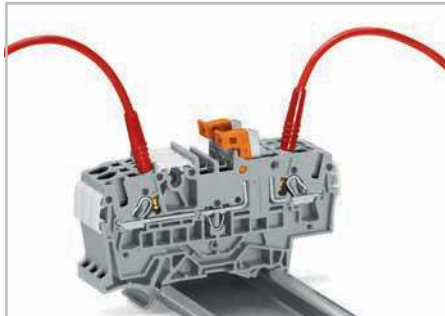

Testing with test plug 2 mm Ø
(max. test voltage: 42 V)

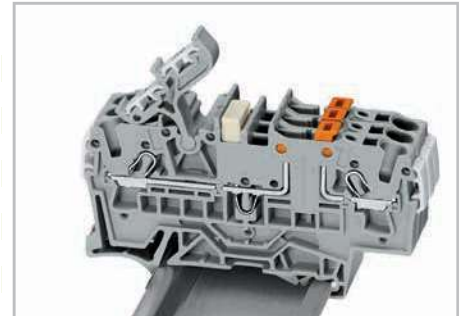

Additional marking option via pivoting marking adapter

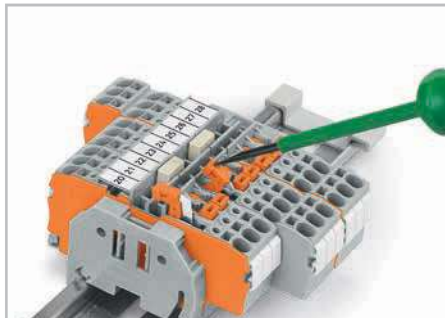

2- and 4-conductor disconnect terminal blocks for test und measurement
Opening the knife disconnect.

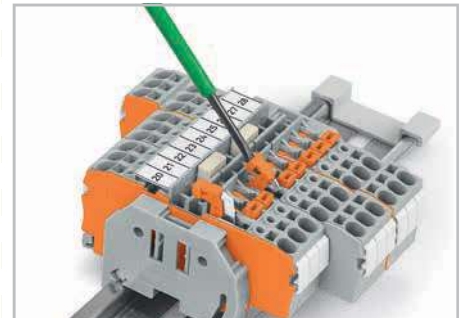

2- and 4-conductor disconnect terminal blocks for test and measurement
Closing the knife disconnect.



Carrier terminal block with disconnect plug in parked position.



Carrier terminal block with disconnect plug in operating position.

TOPJOB® S

Disconnect Terminal Blocks for Test and Measurement, Through Terminal Blocks of Same Profile 2.5 (4) mm², 2002 Series

0.25 ... 2.5 (4) mm ² ① 400 V/6 kV/3 ② I _N 16 A Terminal block width 5.2 mm / 0.205 in. 10 ... 12 mm / 0.43 in. ③	AWG 22 ... 12 300 V, 15 A ④ 300 V, 10 A ⑤	0.25 ... 2.5 (4) mm ² ① 400 V/6 kV/3 ② I _N 16 A Terminal block width 5.2 mm / 0.205 in. 10 ... 12 mm / 0.43 in. ③	AWG 22 ... 12 300 V, 15 A ④	0.25 ... 2.5 (4) mm ² ① 400 V/6 kV/3 ② I _N 16 A Terminal block width 5.2 mm / 0.205 in. 10 ... 12 mm / 0.43 in. ③	AWG 22 ... 12 300 V, 15 A ④ 300 V, 10 A ⑤
---	---	---	--------------------------------	---	---

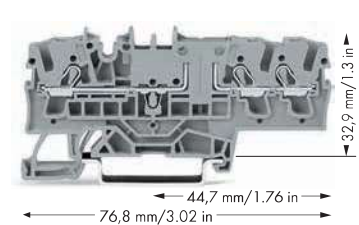
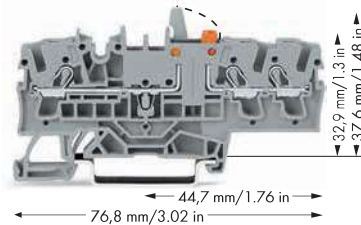
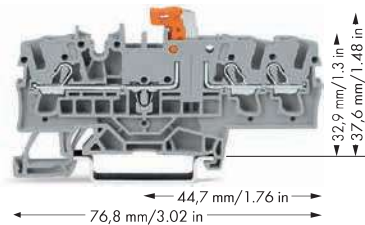

Item No.	Pack. Unit	Item No.	Pack. Unit	Item No.	Pack. Unit
3-conductor disconnect terminal block for test and measurement, with test point, orange disconnect link		3-conductor disconnect terminal block for test and measurement with mechanical interlock, with test point, orange disconnect link		3-conductor through terminal block, with test point, same profile as 3-conductor disconnect terminal block	
gray 2002-1771	50	gray 2002-1771/401-000	50	gray 2002-1701	50
blue 2002-1774	50	blue 2002-1774/401-000	50	blue 2002-1704	50
orange 2002-1772	50	orange 2002-1772/401-000	50	orange 2002-1702	50
Other terminal blocks with the same profile:					
Carrier				2002-1761	Page 88
Fuse				2002-1781	Page 62

2002 Series Accessories

Appropriate marking systems: WMB/WMB Inline/Marking strips

End and intermediate plate, 1 mm thick orange 2002-1792 100 (4x25) gray 2002-1791 100 (4x25)	Protective warning marker, with high-voltage symbol, black, for 5 terminal blocks yellow 2002-115 100 (4x25)	Customized staggered jumper, insulated, I_N 25 A, light gray 1-3 2002-473/011-000 100 (4x25) 1-3-5 2002-475/011-000 1-3-5-7 2002-477/011-000 1-3-5-7-9 2002-479/011-000 1-3-5-7-9-11 2002-481/011-000 50 (2x25)
Insulation stop, 5 pcs/strip, 0.25 ... 0.5 mm² light gray 2002-171 200 (8x25)	Push-in type jumper bar, insulated, I_N 25 A, light gray from 1 to 3 2002-433 200 (8x25) from 1 to 4 2002-434 200 (8x25) from 1 to 5 2002-435 100 (4x25) from 1 to 6 2002-436 100 (4x25) from 1 to 7 2002-437 100 (4x25) from 1 to 8 2002-438 100 (4x25) from 1 to 9 2002-439 100 (4x25) from 1 to 10 2002-440 100 (4x25)	Adjacent jumper for continuous commoning, insulated, I_N 25 A, light gray 2-way 2002-400 100 (4x25)
Insulation stop, 5 pcs/strip, 0.75 ... 1 mm² dark gray 2002-172 200 (8x25)	Staggered jumper, insulated, I_N 25 A, light gray 2-way 2002-472 100 (4x25) 3-way 2002-473 100 (4x25) 4-way 2002-474 100 (4x25) 5-way 2002-475 50 (2x25) 6-way 2002-476 50 (2x25) 7-way 2002-477 50 (2x25) 8-way 2002-478 50 (2x25) 9-way 2002-479 50 (2x25) 10-way 2002-480 50 (2x25) 11-way 2002-481 50 (2x25) 12-way 2002-482 50 (2x25)	Modular TOPJOB® S connector, can be snapped together, for jumper contact slot, gray 2002-511 100 (4x25)
Push-in type jumper bar, insulated, I_N 25 A, light gray 2-way 2002-402 200 (8x25) 3-way 2002-403 200 (8x25) 4-way 2002-404 200 (8x25) 5-way 2002-405 100 (4x25) 6-way 2002-406 100 (4x25) 7-way 2002-407 100 (4x25) 8-way 2002-408 100 (4x25) 9-way 2002-409 100 (4x25) 10-way 2002-410 100 (4x25)		Spacer module, can be snapped together, e.g., for bridging commoned terminal blocks, gray 2002-549 100 (4x25)
Push-in type wire jumper, insulated, I_N 18 A, wire size 1.5 mm² L = 60 mm 2009-412 100 (10x10) L = 110 mm 2009-414 100 (10x10) L = 250 mm 2009-416 100 (10x10)		End plate, for modular TOPJOB® S connectors, 1.5 mm thick, gray 2002-541 100 (4x25)
		TOPJOB® S L-test plug module, can be snapped together, gray 2002-611 100 (4x25)

Approvals see www.wago.com

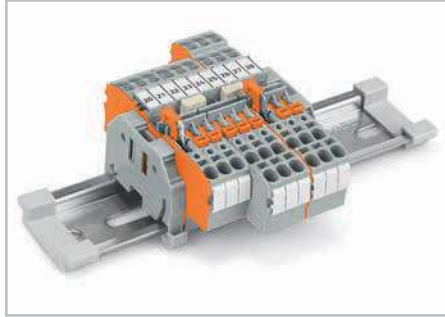

One center and two side marker slots for WMB markers or marking strips. Dual jumper slots, in the same position as the 2002 Series terminal blocks. Commoning options in front of or behind the knife disconnect, depending on the power supply direction.

- 1 Conductor sizes: 0.25 mm² ... 4 mm² "s + f-st"; Push-in conductor sizes: 0.75 mm² ... 4 mm² "s" and 0.75 mm² ... 2.5 mm² "insulated ferrules, 12 mm"
- 2 400 V = rated voltage
6 kV = rated surge voltage
3 = pollution degree
(see Full Line Catalog, Volume 1, Section 14)
- 3 Strip length, see packaging or instructions.
- 4 See application notes for:
Colored push-in type jumper bars, page 163
Staggered jumper, page 166
Adjacent jumper for continuous commoning, page 163
Push-in type wire jumper, page 164
TOPJOB® S connector, page 158
TOPJOB® S L-type test plug module, page 162

Accessories

Test plug adapter,



for 4 mm Ø test plug
gray **2009-174** 100 (4x25)

Testing tap,



for max. 2.5 mm²
gray **2009-182** 100 (4x25)

Banana plug,



for socket 4 mm Ø,
color mixed
215-111 50

Double-deck marker carrier,



pivoting
gray **2002-121** 50 (2x25)

WMB Multi marking system,



10 strips with 10 markers per card,
stretchable 5 ... 5.2 mm
plain **793-5501** 5

WMB Inline, plain,



stretchable 5 ... 5.2 mm,
1,500 WMB markers, 5 mm, on roll
white **2009-115** 1

Marking strip, plain,



11 mm wide,
50 m roll
white **2009-110** 1

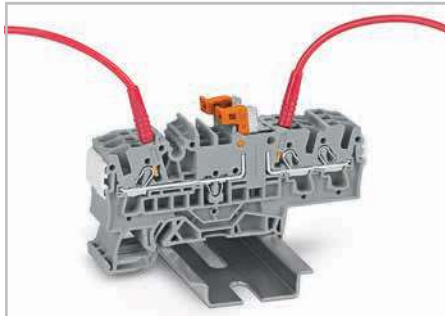

Testing with test plug 2 mm Ø (max. test voltage: 42 V)

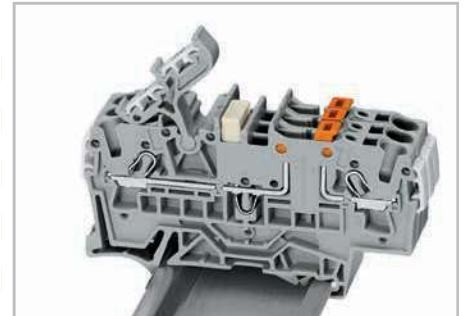

Additional marking option via pivoting marking adapter

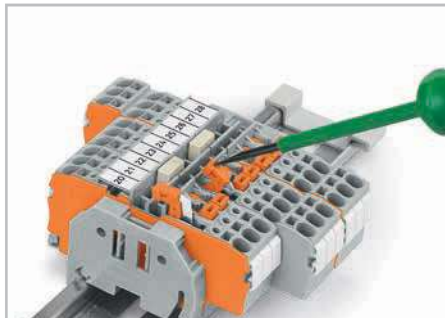

2- and 4-conductor disconnect terminal blocks for test und measurement
Opening the knife disconnect.

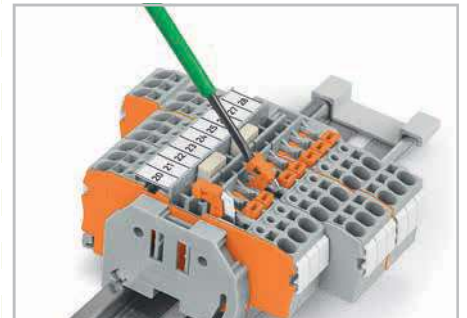

2- and 4-conductor disconnect terminal blocks for test and measurement
Closing the knife disconnect.



Carrier terminal block with disconnect plug in parked position.



Carrier terminal block with disconnect plug in operating position.

TOPJOB® S

Disconnect Terminal Blocks for Test and Measurement, Through Terminal Blocks of Same Profile 2.5 (4) mm², 2002 Series

0.25 ... 2.5 (4) mm ² ① 400 V/6 kV/3 ② I _N 16 A Terminal block width 5.2 mm / 0.205 in. 10 ... 12 mm / 0.43 in. ③	AWG 22 ... 12 300 V, 15 A ④ 300 V, 15 A ⑤	0.25 ... 2.5 (4) mm ² ① 400 V/6 kV/3 ② I _N 16 A Terminal block width 5.2 mm / 0.205 in. 10 ... 12 mm / 0.43 in. ③	AWG 22 ... 12 300 V, 15 A ④ 300 V, 15 A ⑤	0.25 ... 2.5 (4) mm ² ① 400 V/6 kV/3 ② I _N 16 A Terminal block width 5.2 mm / 0.205 in. 10 ... 12 mm / 0.43 in. ③	AWG 22 ... 12 300 V, 15 A ④ 300 V, 15 A ⑤
---	---	---	---	---	---

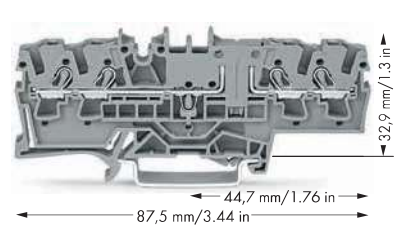
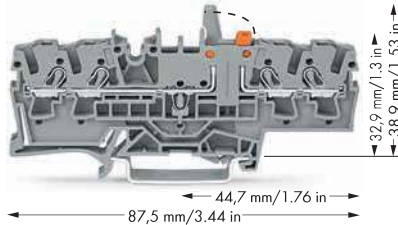
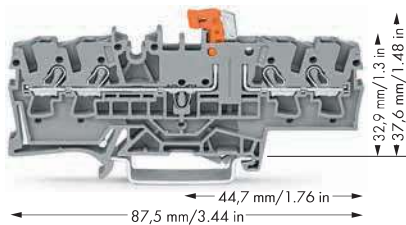

Item No.	Pack. Unit	Item No.	Pack. Unit	Item No.	Pack. Unit
4-conductor disconnect terminal block for test and measurement, with test point, orange disconnect link		4-conductor disconnect terminal block for test and measurement with mechanical interlock, with test point, orange disconnect link		4-conductor through terminal block, with test point, same profile as 4-conductor disconnect terminal block	
gray 2002-1871	50	gray 2002-1871/401-000	50	gray 2002-1801	50
blue 2002-1874	50	blue 2002-1874/401-000	50	blue 2002-1804	50
orange 2002-1872	50	orange 2002-1872/401-000	50	orange 2002-1802	50
Other terminal blocks with the same profile:					
		Carrier	2002-1861	Page 88	
		Fuse	2002-1881	Page 62	

2002 Series Accessories

Appropriate marking systems: WMB/WMB Inline/Marking strips

End and intermediate plate, 1 mm thick orange 2002-1892 100 (4x25) gray 2002-1891 100 (4x25)	Protective warning marker, with high-voltage symbol, black, for 5 terminal blocks yellow 2002-115 100 (4x25)	Customized staggered jumper, insulated, I_N 25 A, light gray 1-3 2002-473/011-000 100 (4x25) 1-3-5 2002-475/011-000 1-3-5-7 2002-477/011-000 1-3-5-7-9 2002-479/011-000 1-3-5-7-9-11 2002-481/011-000 50 (2x25)
Insulation stop, 5 pcs/strip, 0.25 ... 0.5 mm² light gray 2002-171 200 (8x25)	Push-in type jumper bar, insulated, I_N 25 A, light gray from 1 to 3 2002-433 200 (8x25) from 1 to 4 2002-434 200 (8x25) from 1 to 5 2002-435 100 (4x25) from 1 to 6 2002-436 100 (4x25) from 1 to 7 2002-437 100 (4x25) from 1 to 8 2002-438 100 (4x25) from 1 to 9 2002-439 100 (4x25) from 1 to 10 2002-440 100 (4x25)	Adjacent jumper for continuous commoning, insulated, I_N 25 A, light gray 2-way 2002-400 100 (4x25)
Insulation stop, 5 pcs/strip, 0.75 ... 1 mm² dark gray 2002-172 200 (8x25)	Staggered jumper, insulated, I_N 25 A, light gray 2-way 2002-472 100 (4x25) 3-way 2002-473 100 (4x25) 4-way 2002-474 100 (4x25) 5-way 2002-475 50 (2x25) 6-way 2002-476 50 (2x25) 7-way 2002-477 50 (2x25) 8-way 2002-478 50 (2x25) 9-way 2002-479 50 (2x25) 10-way 2002-480 50 (2x25) 11-way 2002-481 50 (2x25) 12-way 2002-482 50 (2x25)	Modular TOPJOB® S connector, can be snapped together, for jumper contact slot, gray 2002-511 100 (4x25)
Push-in type jumper bar, insulated, I_N 25 A, light gray 2-way 2002-402 200 (8x25) 3-way 2002-403 200 (8x25) 4-way 2002-404 200 (8x25) 5-way 2002-405 100 (4x25) 6-way 2002-406 100 (4x25) 7-way 2002-407 100 (4x25) 8-way 2002-408 100 (4x25) 9-way 2002-409 100 (4x25) 10-way 2002-410 100 (4x25)		Spacer module, can be snapped together, e.g., for bridging commoned terminal blocks, gray 2002-549 100 (4x25)
Push-in type wire jumper, insulated, I_N 18 A, wire size 1.5 mm² L = 60 mm 2009-412 100 (10x10) L = 110 mm 2009-414 100 (10x10) L = 250 mm 2009-416 100 (10x10)		End plate, for modular TOPJOB® S connectors, 1.5 mm thick, gray 2002-541 100 (4x25)
		TOPJOB® S L-test plug module, can be snapped together, gray 2002-611 100 (4x25)



Carrier terminal block with disconnect plug in parked position.
Application example showing a 2-conductor carrier terminal block 2002-1661 with disconnect plug

- 1 Conductor sizes: 0.25 mm² ... 4 mm² "s + f-st";
Push-in conductor sizes: 0.75 mm² ... 4 mm² "s"
"insulated ferrules, 12 mm"
- 2 400 V = rated voltage
6 kV = rated surge voltage
3 = pollution degree
(see Full Line Catalog, Volume 1, Section 14)
- 3 Strip length, see packaging or instructions.
- 4 See application notes for:
Colored push-in type jumper bars, page 163
Staggered jumper, page 166
Adjacent jumper for continuous commoning, page 163
Push-in type wire jumper, page 164
TOPJOB® S connector, page 158
TOPJOB® S L-type test plug module, page 162

Accessories

Test plug adapter,

for 4 mm Ø test plug
gray **2009-174** 100 (4x25)

Testing tap,

for max. 2.5 mm²
gray **2009-182** 100 (4x25)

Banana plug,

for socket 4 mm Ø,
color mixed
215-111 50

Double-deck marker carrier,

pivoting
gray **2002-121** 50 (2x25)

WMB Multi marking system,

10 strips with 10 markers per card,
stretchable 5 ... 5.2 mm
plain **793-5501** 5

WMB Inline, plain,

stretchable 5 ... 5.2 mm,
1,500 WMB markers, 5 mm, on roll
white **2009-115** 1

Marking strip, plain,

11 mm wide,
50 m roll
white **2009-110** 1



2-conductor disconnect terminal block for test and measurement, with knife disconnect and mechanical interlock
Open position



2-conductor disconnect terminal block for test and measurement, with knife disconnect and mechanical interlock
Top view

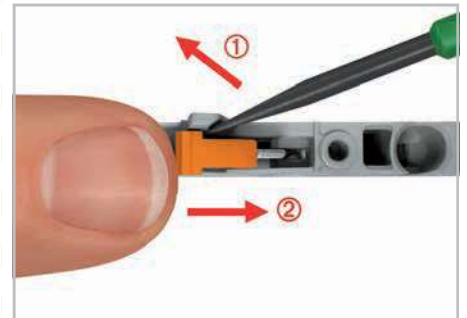

2-conductor disconnect terminal block for test and measurement, with knife disconnect and mechanical interlock
Closing of knife disconnect

TOPJOB® S

Fuse Terminal Blocks 2.5 (4) mm²

2002 Series

0.25 ... 2.5 (4) mm ² ① 400 V/6 kV/3 ② I _N 10 A ③ Terminal block width 5.2 mm / 0.205 in. 10 ... 12 mm / 0.43 in.④	AWG 22 ... 12 300 V, 10 A ⑤ 300 V, 10 A ⑥	0.25 ... 2.5 (4) mm ² ① 400 V/6 kV/3 ② I _N 10 A ③ Terminal block width 5.2 mm / 0.205 in. 10 ... 12 mm / 0.43 in.④	AWG 22 ... 12 300 V, 10 A ⑤ 300 V, 10 A ⑥	0.25 ... 2.5 (4) mm ² ① 400 V/6 kV/3 ② I _N 10 A ③ Terminal block width 5.2 mm / 0.205 in. 10 ... 12 mm / 0.43 in.④	AWG 22 ... 12 300 V, 10 A ⑤ 300 V, 10 A ⑥
--	---	--	---	--	---

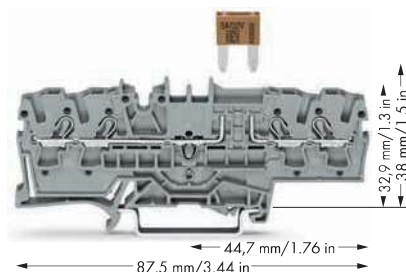
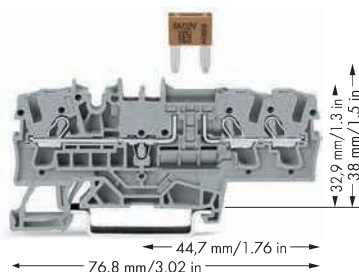
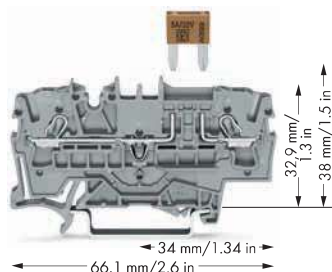







Item No.	Pack. Unit	Item No.	Pack. Unit	Item No.	Pack. Unit
2-conductor fuse terminal block, with test point, for blade-style fuses acc. to DIN 72581-3f, ISO 8820-3		3-conductor fuse terminal block, with test point, for blade-style fuses acc. to DIN 72581-3f, ISO 8820-3		4-conductor fuse terminal block, with test point, for blade-style fuses acc. to DIN 72581-3f, ISO 8820-3	
gray 2002-1681 50		gray 2002-1781 50		gray 2002-1881 50	
Blade-style fuses are not offered by WAGO		Blade-style fuses are not offered by WAGO		Blade-style fuses are not offered by WAGO	
Other terminal blocks with the same profile: Through 2002-1601 Page 56		Other terminal blocks with the same profile: Through 2002-1701 Page 58		Other terminal blocks with the same profile: Through 2002-1801 Page 60	
Item-Specific Accessories		Item-Specific Accessories		Item-Specific Accessories	
End and intermediate plate, 1 mm thick		End and intermediate plate, 1 mm thick		End and intermediate plate, 1 mm thick	
orange 2002-1692 100 (4x25)		orange 2002-1792 100 (4x25)		orange 2002-1892 100 (4x25)	
gray 2002-1691 100 (4x25)		gray 2002-1791 100 (4x25)		gray 2002-1891 100 (4x25)	

2002 Series Accessories

Appropriate marking systems: WMB/WMB Inline/Marking strips

Insulation stop, 5 pcs/strip, 0.25 ... 0.5 mm ² light gray 2002-171 200 (8x25)	Push-in type jumper bar, insulated, I _N 25 A, light gray from 1 to 3 2002-433 200 (8x25) from 1 to 4 2002-434 200 (8x25) from 1 to 5 2002-435 100 (4x25) from 1 to 6 2002-436 100 (4x25) from 1 to 7 2002-437 100 (4x25) from 1 to 8 2002-438 100 (4x25) from 1 to 9 2002-439 100 (4x25) from 1 to 10 2002-440 100 (4x25)	Staggered jumper, ⑤ insulated, I _N 25 A, light gray 2-way 2002-472 100 (4x25) 3-way 2002-473 100 (4x25) 4-way 2002-474 100 (4x25) 5-way 2002-475 50 (2x25) 6-way 2002-476 50 (2x25) 7-way 2002-477 50 (2x25) 8-way 2002-478 50 (2x25) 9-way 2002-479 50 (2x25) 10-way 2002-480 50 (2x25) 11-way 2002-481 50 (2x25) 12-way 2002-482 50 (2x25)
Insulation stop, 5 pcs/strip, 0.75 ... 1 mm ² dark gray 2002-172 200 (8x25)	Push-in type wire jumper, ⑤ insulated, I _N 18 A, wire size 1.5 mm ² L = 60 mm 2009-412 100 (10x10) L = 110 mm 2009-414 100 (10x10) L = 250 mm 2009-416 100 (10x10)	Adjacent jumper for continuous commoning, insulated, ⑤ I _N 25 A, light gray 2-way 2002-400 100 (4x25)
Push-in type jumper bar, insulated, ⑤ I _N 25 A, light gray 2-way 2002-402 200 (8x25) 3-way 2002-403 200 (8x25) 4-way 2002-404 200 (8x25) 5-way 2002-405 100 (4x25) 6-way 2002-406 100 (4x25) 7-way 2002-407 100 (4x25) 8-way 2002-408 100 (4x25) 9-way 2002-409 100 (4x25) 10-way 2002-410 100 (4x25)	Test plug, with 500 mm cable, 2 mm Ø red 210-136 50	
Protective warning marker, with high-voltage symbol, black, for 5 terminal blocks yellow 2002-115 100 (4x25)	Banana plug, for socket 4 mm Ø, color mixed 215-111 50	
Double-deck marker carrier, pivoting gray 2002-121 50 (2x25)		

- ① Conductor sizes: 0.25 mm² ... 4 mm² "s + fst";
Push-in conductor sizes: 0.75 mm² ... 4 mm² "s"
and 0.75 mm² ... 2.5 mm²
"insulated ferrules, 12 mm"
- ② 400 V = rated voltage
6 kV = rated surge voltage
3 = pollution degree
(see Full Line Catalog, Volume 1, Section 14)
- ③ - Individual arrangement: 10 A
- Block arrangement: 5 A
Protection against direct contact must be observed for
42 V and higher voltages
- ④ Strip length, see packaging or instructions.
- ⑤ See application notes for:
Colored push-in type jumper bars, page 163
Staggered jumper, page 166
Adjacent jumper for continuous commoning,
page 163
Push-in type wire jumper, page 164
TOPJOB® S connector, page 158
TOPJOB® S L-type test plug module, page 162

Accessories			
⑤ 	can be snapped together, for jumper contact slot	gray	2002-511 100 (4x25)
	can be snapped together, e.g., for bridging commoned terminal blocks	gray	2002-549 100 (4x25)
	for modular TOPJOB® S connectors, 1.5 mm thick	gray	2002-541 100 (4x25)
⑤ 	can be snapped together	gray	2002-611 100 (4x25)
	for 4 mm Ø test plug	gray	2009-174 100 (4x25)
	for max. 2.5 mm ²	gray	2009-182 100 (4x25)
	10 strips with 10 markers per card, stretchable 5 ... 5.2 mm	plain	793-5501 5

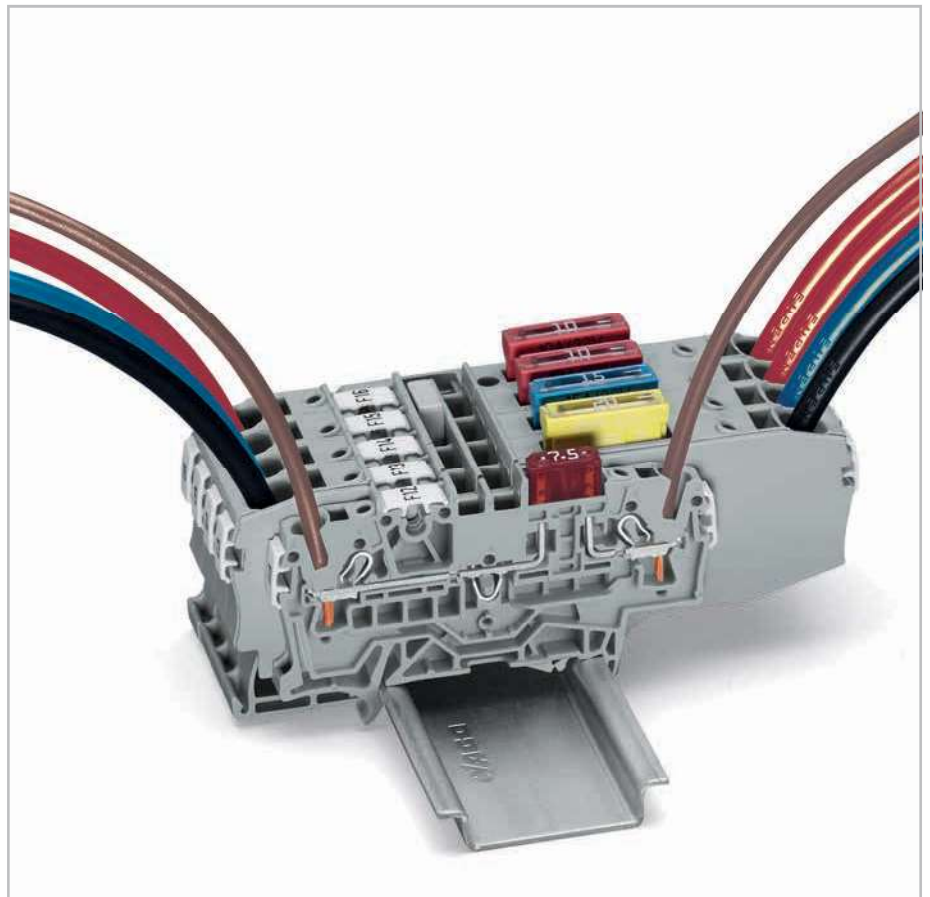

Selecting the correct fuse cartridge is important for product safety within applications, as well as for fuse cartridge service life and reliability. Fuse cartridges can operate perfectly as protection (break-off point) if they are properly selected and used according to manufacturer specifications.

The rated currents of the fuse cartridges are defined differently in international standards.

Due to different current rating definitions, the recommended current-carrying permanent capacity of the fuses is max. 80% of their rated current according to DIN 72581 part 3 (for an ambient operating temperature of 23 °C).

Regarding product safety, it is generally necessary to test fuse cartridges under normal conditions and operational failures within your application.

TOPJOB® S

Fuse Disconnect Terminal Blocks with Pivoting Fuse Holder 2.5 (4) mm² for Miniature Fuses 5 x 20 mm, 2002 Series

0.25 ... 2.5 (4) mm ² ① 250 V/6 kV/3 ② I _N 6.3 A Terminal block width 6.2 mm / 0.244 in. 10 ... 12 mm / 0.43 in. ③	AWG 22 ... 12 250 V, 6.3 A ④ 250 V, 6.3 A ⑤	0.25 ... 2.5 (4) mm ² ① 250 V/6 kV/3 ② I _N 6.3 A Terminal block width 6.2 mm / 0.244 in. 10 ... 12 mm / 0.43 in. ③	AWG 22 ... 12 250 V, 6.3 A ④ 250 V, 6.3 A ⑤	0.25 ... 2.5 (4) mm ² ① 250 V/6 kV/3 ② I _N 6.3 A Terminal block width 6.2 mm / 0.244 in. 10 ... 12 mm / 0.43 in. ③	AWG 22 ... 12 250 V, 6.3 A ④ 250 V, 6.3 A ⑤
--	---	--	---	--	---

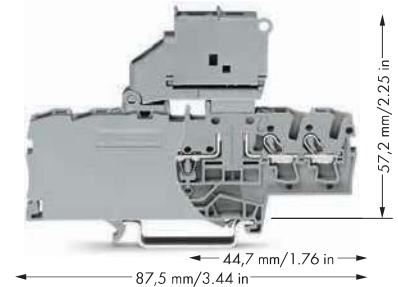
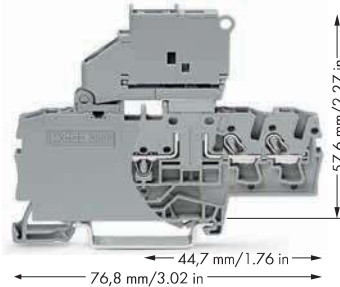
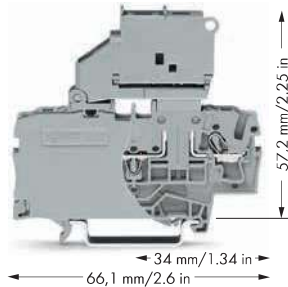

Item No.	Pack. Unit	Item No.	Pack. Unit	Item No.	Pack. Unit
2-conductor fuse disconnect terminal block with pivoting fuse holder, for miniature fuses 5 x 20 mm, without blown fuse indication Both nominal voltage and current are given by the fuse.		3-conductor fuse disconnect terminal block with pivoting fuse holder, for miniature fuses 5 x 20 mm, without blown fuse indication Both nominal voltage and current are given by the fuse.		4-conductor fuse disconnect terminal block with pivoting fuse holder, for miniature fuses 5 x 20 mm, without blown fuse indication Both nominal voltage and current are given by the fuse.	
● gray	2002-1611 50	● gray	2002-1711 50	● gray	2002-1811 50
2-conductor fuse disconnect terminal block with pivoting fuse holder, for miniature fuses 5 x 20 mm, with blown fuse indication by LED, gray Both nominal voltage and current are given by the LED or fuse. Leakage current in case of blown fuse: LED 2mA		3-conductor fuse disconnect terminal block with pivoting fuse holder, for miniature fuses 5 x 20 mm, with blown fuse indication by LED, gray Both nominal voltage and current are given by the LED or fuse. Leakage current in case of blown fuse: LED 2mA		4-conductor fuse disconnect terminal block with pivoting fuse holder, for miniature fuses 5 x 20 mm, with blown fuse indication by LED, gray Both nominal voltage and current are given by the LED or fuse. Leakage current in case of blown fuse: LED 2mA	
● 12 ... 30 V	2002-1611/1000-541 50	● 12 ... 30 V	2002-1711/1000-541 50	● 12 ... 30 V	2002-1811/1000-541 50
● 30 ... 65 V	2002-1611/1000-542 50	● 30 ... 65 V	2002-1711/1000-542 50	● 30 ... 65 V	2002-1811/1000-542 50
● 230 V	2002-1611/1000-836 50	● 230 V	2002-1711/1000-836 50	● 230 V	2002-1811/1000-836 50
● 120 V	2002-1611/1000-867 50	● 120 V	2002-1711/1000-867 50	● 120 V	2002-1811/1000-867 50

Accessories

Appropriate marking systems: WMB/WMB Inline/Marking strips

End plate for fuse terminal blocks, 2 mm thick orange 2002-992 100 (4x25) gray 2002-991 100 (4x25)	Push-in type jumper bar, insulated, I _N 32 A, light gray 2-way 2004-402 200 (8x25) 3-way 2004-403 200 (8x25) 4-way 2004-404 100 (4x25) 5-way 2004-405 100 (4x25) 6-way 2004-406 100 (4x25) 7-way 2004-407 100 (4x25) 8-way 2004-408 100 (4x25) 9-way 2004-409 100 (4x25) 10-way 2004-410 100 (4x25)	Push-in type jumper bar, insulated, I _N 32 A, light gray from 1 to 3 2004-433 200 (8x25) from 1 to 4 2004-434 200 (8x25) from 1 to 5 2004-435 100 (4x25) from 1 to 6 2004-436 100 (4x25) from 1 to 7 2004-437 100 (4x25) from 1 to 8 2004-438 100 (4x25) from 1 to 9 2004-439 100 (4x25) from 1 to 10 2004-440 100 (4x25)
Insulation stop, 5 pcs/strip, 0.25 ... 0.5 mm ² light gray 2002-171 200 (8x25)		
Insulation stop, 5 pcs/strip, 0.75 ... 1 mm ² dark gray 2002-172 200 (8x25)		
Push-in type wire jumper, ④ insulated, I _N 18 A, wire size 1.5 mm ² L = 60 mm 2009-412 100 (10x10) L = 110 mm 2009-414 100 (10x10) L = 250 mm 2009-416 100 (10x10)	Protective warning marker, with high-voltage symbol, black, for 5 terminal blocks yellow 2002-115 100 (4x25)	



Fuse terminal blocks with a width of 6.2 mm can be assembled adjacently. If there is **no** adjacent fuse terminal block at the end of the assembly, an end plate must be used.

- ❶ Conductor sizes: 0.25 mm² ... 4 mm² "s + f-st";
Push-in conductor sizes: 0.75 mm² ... 4 mm² "s"
and 0.75 mm² ... 2.5 mm²
"insulated ferrule, 12 mm"
- ❷ 250 V = rated voltage
6 kV = rated surge voltage
3 = pollution degree
(see Full Line Catalog, Volume 1, Section 14)
- ❸ Strip length, see packaging or instructions.
- ❹ See application notes for:
Push-in type wire jumper, page 164



Pivoting the fuse holder in the locked open position.

When selecting miniature fuses, the maximum power loss listed below should not be exceeded. The power loss is determined according to IEC or EN 60947-7-3/VDE 0611-6 at 23 °C. The temperature rise of the terminal blocks must be checked according to their application and mounting. Higher ambient temperatures place additional strain on fuse cartridges. Therefore, in such applications, the rated current must be reduced if necessary. More details available from the manufacturer.



Exchanging fuse.

Miniature fuses 5 x 20

Series Item No.	Overload and short circuit protection		Short circuit protection only	
	Individual argmt.	Group argmt.	Individual argmt.	Group argmt.
Fuse terminal blocks				
2002-1611	1.6 W	1.6 W	2.5 W	2.5 W
2002-1811				
2002-1611/.....	1.6 W	1.6 W	2.5 W	2.5 W
2002-1811/.....				

Protective warning marker and insulation stop must be applied individually. Due to the 6.2 mm width of the fuse terminal blocks with pivoting fuse holder, 2004 Series jumpers must be used.

TOPJOB® S

Disconnect Terminal Blocks for Test and Measurement without and with Mechanical Interlock with Additional Jumper Position 2.5 (4) mm², 2002 Series

0.25 ... 2.5 (4) mm ² ① 400 V/6 kV/3 ② I _N 16 A Terminal block width 5.2 mm / 0.205 in. 10 ... 12 mm / 0.43 in. ③	AWG 22 ... 12 300 V, 15 A ④	0.25 ... 2.5 (4) mm ² ① 400 V/6 kV/3 ② I _N 16 A Terminal block width 5.2 mm / 0.205 in. 10 ... 12 mm / 0.43 in. ③	AWG 22 ... 12 300 V, 15 A ④	0.25 ... 2.5 (4) mm ² ① 400 V/6 kV/3 ② I _N 16 A Terminal block width 5.2 mm / 0.205 in. 10 ... 12 mm / 0.43 in. ③	AWG 22 ... 12 300 V, 15 A ④
---	--------------------------------	---	--------------------------------	---	--------------------------------

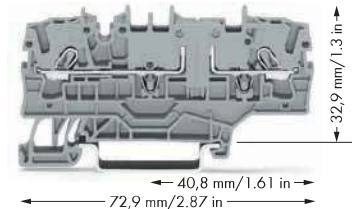
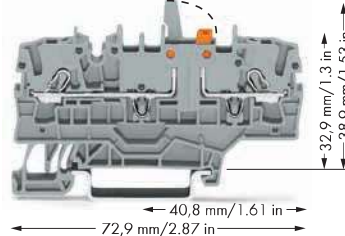
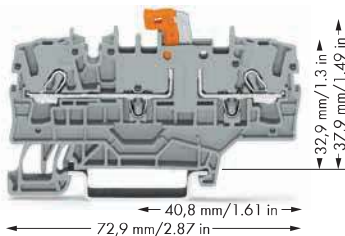

Item No.	Pack. Unit	Item No.	Pack. Unit	Item No.	Pack. Unit
2-conductor disconnect terminal block for test and measurement, with test point, orange disconnect link, with additional jumper position		2-conductor disconnect terminal block for test and measurement with mechanical interlock, with test point, orange disconnect link, with additional jumper position		2-conductor through terminal block, with test point, with additional jumper position, same profile as 2-conductor disconnect terminal block	
gray 2002-1971 50		gray 2002-1971/401-000 50		gray 2002-1901 50	
blue 2002-1974 50		orange 2002-1972/401-000 50		blue 2002-1904 50	
orange 2002-1972 50		blue 2002-1974/401-000 50		orange 2002-1902 50	
				2-conductor ground terminal block	
				green-yellow 2002-1907 50	
				Other terminal blocks with the same profile:	
				Carrier 2002-1961 Page 88	
				Fuse 2002-1981 Page 69	

2002 Series Accessories

Appropriate marking systems: WMB/WMB Inline/Marking strips

End and intermediate plate, 1 mm thick orange 2002-1992 100 (4x25) gray 2002-1991 100 (4x25)	Push-in type jumper bar, insulated, I _N 25 A, light gray from 1 to 3 2002-433 200 (8x25) from 1 to 4 2002-434 200 (8x25) from 1 to 5 2002-435 100 (4x25) from 1 to 6 2002-436 100 (4x25) from 1 to 7 2002-437 100 (4x25) from 1 to 8 2002-438 100 (4x25) from 1 to 9 2002-439 100 (4x25) from 1 to 10 2002-440 100 (4x25)	Protective warning marker, with high-voltage symbol, black, for 5 terminal blocks yellow 2002-115 100 (4x25)
Insulation stop, 5 pcs/strip, 0.25 ... 0.5 mm ² light gray 2002-171 200 (8x25)		Test plug adapter, for 4 mm Ø test plug gray 2009-174 100 (4x25)
Insulation stop, 5 pcs/strip, 0.75 ... 1 mm ² dark gray 2002-172 200 (8x25)		Testing tap, for max. 2.5 mm ² gray 2009-182 100 (4x25)
Push-in type jumper bar, insulated, ④ I _N 25 A, light gray 2-way 2002-402 200 (8x25) 3-way 2002-403 200 (8x25) 4-way 2002-404 200 (8x25) 5-way 2002-405 100 (4x25) 6-way 2002-406 100 (4x25) 7-way 2002-407 100 (4x25) 8-way 2002-408 100 (4x25) 9-way 2002-409 100 (4x25) 10-way 2002-410 100 (4x25)	Staggered jumper, ④ insulated, I _N 25 A, light gray 2-way 2002-472 100 (4x25) 3-way 2002-473 100 (4x25) 4-way 2002-474 100 (4x25) 5-way 2002-475 50 (2x25) 6-way 2002-476 50 (2x25) 7-way 2002-477 50 (2x25) 8-way 2002-478 50 (2x25) 9-way 2002-479 50 (2x25) 10-way 2002-480 50 (2x25) 11-way 2002-481 50 (2x25) 12-way 2002-482 50 (2x25)	Modular TOPJOB® S connector, ④ can be snapped together, for jumper contact slot gray 2002-511 100 (4x25)
Push-in type wire jumper, ④ insulated, I _N 18 A, wire size 1.5 mm ² L = 60 mm 2009-412 100 (10x10) L = 110 mm 2009-414 100 (10x10) L = 250 mm 2009-416 100 (10x10)	Adjacent jumper for continuous commoning, insulated, ④ I _N 25 A, light gray 2-way 2002-400 100 (4x25)	Spacer module, can be snapped together, e.g., for bridging commoned terminal blocks gray 2002-549 100 (4x25)
		End plate, for modular TOPJOB® S connectors, 1.5 mm thick gray 2002-541 100 (4x25)
		TOPJOB® S L-test plug module, ④ can be snapped together gray 2002-611 100 (4x25)
		Test plug, with 500 mm cable, 2 mm Ø red 210-136 50

TOPJOB® S

Fuse Terminal Blocks 2.5 (4) mm²

2002 Series

0.25 ... 2.5 (4) mm ² ① 400 V/6 kV/3 ② I _N 10 A Terminal block width 5.2 mm / 0.205 in. 10 ... 12 mm / 0.43 in. ③	AWG 22 ... 12 12 V, 10 A ④	0.25 ... 2.5 (4) mm ² ① 400 V/6 kV/3 ② I _N 10 A Terminal block width 5.2 mm / 0.205 in. 10 ... 12 mm / 0.43 in. ③	AWG 22 ... 12 24 V, 10 A ④	0.25 ... 2.5 (4) mm ² ① 400 V/6 kV/3 ② I _N 10 A Terminal block width 5.2 mm / 0.205 in. 10 ... 12 mm / 0.43 in. ③	AWG 22 ... 12 48 V, 10 A ④
---	-------------------------------	---	-------------------------------	---	-------------------------------

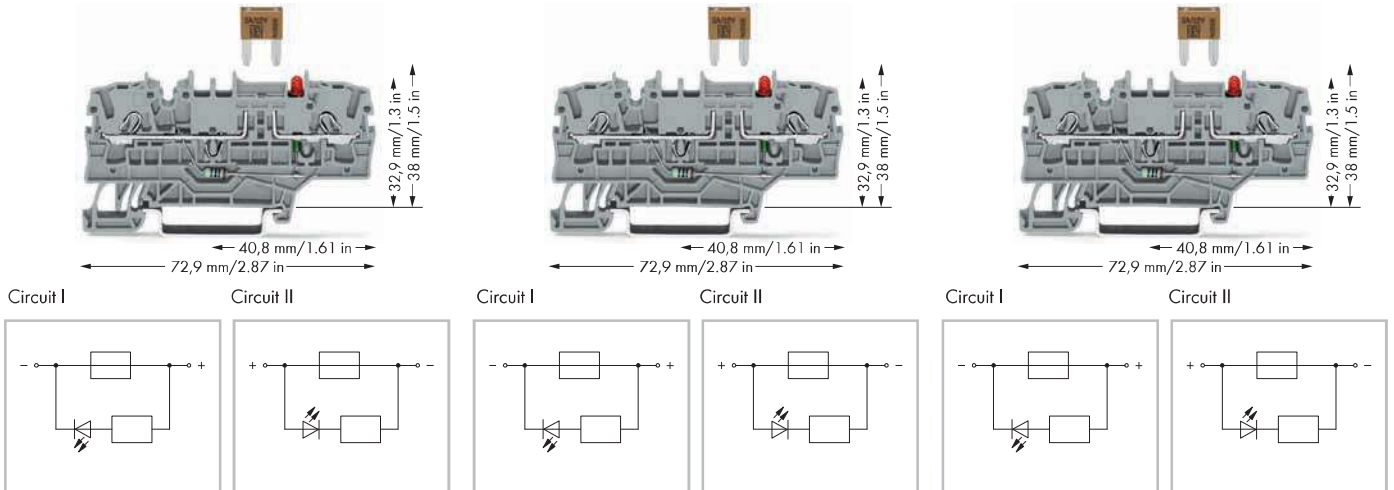

Item No.	Pack. Unit	Item No.	Pack. Unit	Item No.	Pack. Unit
2-conductor fuse terminal block for mini-automotive blade-style fuses, 12V, with test point, with blown fuse indication by LED, LED power consumption: 4.8 mA, gray Both nominal voltage and current are given by the LED or fuse. Blade-style fuses, please note touchproof protection for 42V and higher.		2-conductor fuse terminal block for mini-automotive blade-style fuses, 24 V, with test point, with blown fuse indication by LED, LED power consumption: 4.8 mA, gray Both nominal voltage and current are given by the LED or fuse. Blade-style fuses, please note touchproof protection for 42V and higher.		2-conductor fuse terminal block for mini-automotive blade-style fuses, 48 V, with test point, with blown fuse indication by LED, LED power consumption: 4.8 mA, gray Both nominal voltage and current are given by the LED or fuse. Blade-style fuses, please note touchproof protection for 42V and higher.	
○ Circuit I	2002-1981/1000-429 50	○ Circuit I	2002-1981/1000-413 50	○ Circuit I	2002-1981/1000-414 50
○ Circuit II	2002-1981/1000-449 50	○ Circuit II	2002-1981/1000-434 50	○ Circuit II	2002-1981/1000-435 50
Other terminal blocks with the same profile:					
Through	2002-1901	Page 66			

2002 Series Accessories

Appropriate marking systems: WMB/WMB Inline/Marking strips

End and intermediate plate, 1 mm thick orange 2002-1992 100 (4x25) gray 2002-1991 100 (4x25)	Push-in type wire jumper, ④ insulated, I _N 18 A, wire size 1.5 mm ² L = 60 mm 2009-412 100 (10x10) L = 110 mm 2009-414 100 (10x10) L = 250 mm 2009-416 100 (10x10)	Staggered jumper, ④ insulated, I _N 25 A, light gray 2-way 2002-472 100 (4x25) 3-way 2002-473 100 (4x25) 4-way 2002-474 100 (4x25) 5-way 2002-475 50 (2x25) 6-way 2002-476 50 (2x25) 7-way 2002-477 50 (2x25) 8-way 2002-478 50 (2x25) 9-way 2002-479 50 (2x25) 10-way 2002-480 50 (2x25) 11-way 2002-481 50 (2x25) 12-way 2002-482 50 (2x25)
Insulation stop, 5 pcs/strip, 0.25 ... 0.5 mm ² light gray 2002-171 200 (8x25)	Adjacent jumper for continuous commoning, insulated, ④ I _N 25 A, light gray 2-way 2002-400 100 (4x25)	
Insulation stop, 5 pcs/strip, 0.75 ... 1 mm ² dark gray 2002-172 200 (8x25)	Push-in type jumper bar, insulated, ④ I _N 25 A, light gray 2-way 2002-402 200 (8x25) 3-way 2002-403 200 (8x25) 4-way 2002-404 200 (8x25) 5-way 2002-405 100 (4x25) 6-way 2002-406 100 (4x25) 7-way 2002-407 100 (4x25) 8-way 2002-408 100 (4x25) 9-way 2002-409 100 (4x25) 10-way 2002-410 100 (4x25)	Protective warning marker, with high-voltage symbol, black, for 5 terminal blocks yellow 2002-115 100 (4x25)

Approvals see www.wago.com

0.25 ... 2.5 (4) mm² ① AWG 22 ... 12
 400 V/6 kV/3 ② 250 V, 10 A ③
 I_N 10 A

Terminal block width 5.2 mm / 0.205 in.

8 10 ... 12 mm / 0.43 in. ③

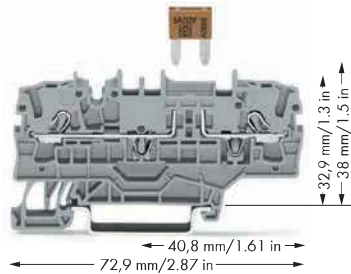

- ① Conductor sizes: 0.25 mm² ... 4 mm² "s + f-st";
 Push-in conductor sizes: 0.75 mm² ... 4 mm² "s"
 and 0.75 mm² ... 2.5 mm²
 "insulated ferrules, 12 mm"
- ② 400 V = rated voltage
 6 kV = rated surge voltage
 3 = pollution degree
 (see Full Line Catalog, Volume 1, Section 14)
- ③ Strip length, see packaging or instructions.
- ④ See application notes for:
 Colored push-in type jumper bars, page 163
 Staggered jumper, page 166
 Adjacent jumper for continuous commoning,
 page 163
 Push-in type wire jumper, page 164
 TOPJOB® S connector, page 158
 TOPJOB® S L-type test plug module, page 162

Item No.	Pack. Unit
2-conductor fuse terminal block for mini-automotive blade-style fuses,	
with test point, with additional jumper position, without blown fuse indication	
Both nominal voltage and current are given by the fuse.	
Blade-style fuses, please note touchproof protection for 42V and higher.	
○ gray	2002-1981 50
Blade-style fuses are not offered by WAGO	
WMB Inline, plain,	
stretchable 5 ... 5.2 mm,	
1,500 WMB markers, 5 mm, on roll	
white	2009-115 1
WMB Multi marking system,	
10 strips with 10 markers per card,	
stretchable 5 ... 5.2 mm	
plain	793-5501 5
Double-deck marker carrier,	
pivoting	
gray	2002-121 50 (2x25)

Fuse Disconnect Terminal Blocks with Pivoting Fuse Holder and Additional Jumper Position for Miniature Fuses 5 x 20 mm, 2002 Series

0.25 ... 2.5 (4) mm ² ① 250 V/6 kV/3 ② I _N 6.3 A Terminal block width 6.2 mm / 0.244 in. 10 ... 12 mm / 0.43 in. ③	AWG 22 ... 12 600 V, 6,3 A ④	0.25 ... 2.5 (4) mm ² ① 250 V/6 kV/3 ② I _N 6.3 A Terminal block width 6.2 mm / 0.244 in. 10 ... 12 mm / 0.43 in. ③	AWG 22 ... 12 30 V, 6,3 A ④
--	---------------------------------	--	--------------------------------

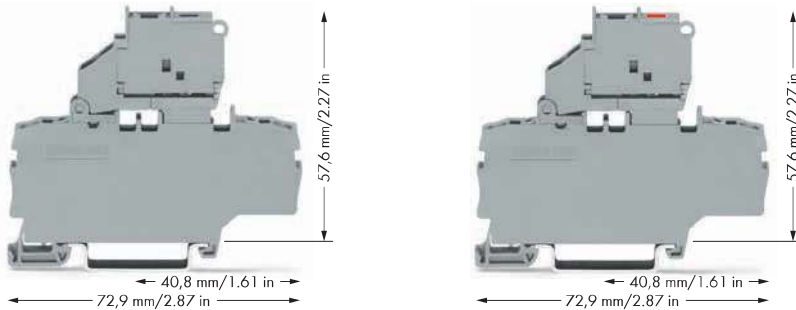

- ① Conductor sizes: 0.25 mm² ... 4 mm² "s + f-st"; Push-in conductor sizes: 0.75 mm² ... 4 mm² "s" and 0.75 mm² ... 2.5 mm² "insulated ferrule, 12 mm"
- ② 250 V = rated voltage
6 kV = rated surge voltage
3 = pollution degree
(see Full Line Catalog, Volume 1, Section 14)
- ③ Strip length, see packaging or instructions.
- ④ See application notes for:
Push-in type wire jumper, page 164

Item No.	Pack. Unit	Item No.	Pack. Unit
2-conductor fuse disconnect terminal block with pivoting fuse holder, with additional jumper position, for miniature fuses 5 x 20 mm, without blown fuse indication		2-conductor fuse disconnect terminal block with pivoting fuse holder, with additional jumper position, with blown fuse indication by LED, gray	
Both nominal voltage and current are given by the fuse.		Both nominal voltage and current are given by the LED or fuse. Leakage current in case of blown fuse: LED 2mA	
gray	2002-1911	50	
		12 ... 30 V	2002-1911/1000-541 50
		30 ... 65 V	2002-1911/1000-542 50
		120 V	2002-1911/1000-867 50
		230 V	2002-1911/1000-836 50

Series Item No.	Overload and short circuit protection		Short circuit protection only	
	Individual argmt.	Group argmt.	Individual argmt.	Group argmt.
Fuse terminal blocks				
2002-1911	1.6 W	1.6 W	2.5 W	2.5 W
2002-1911/.....	1.6 W	1.6 W	2.5 W	2.5 W

Protective warning marker and insulation stop must be applied individually. Due to the 6.2 mm width of the fuse terminal blocks with pivoting fuse holder, 2004 Series jumpers must be used.

2002 Series Accessories

Appropriate marking systems: WMB/WMB Inline/Marking strips

End plate for fuse terminal blocks, 2 mm thick orange 2002-992 100 (4x25) gray 2002-991 100 (4x25)	Push-in type jumper bar, insulated, I _N 32 A, light gray from 1 to 3 2004-433 200 (8x25) from 1 to 4 2004-434 200 (8x25) from 1 to 5 2004-435 100 (4x25) from 1 to 6 2004-436 100 (4x25) from 1 to 7 2004-437 100 (4x25) from 1 to 8 2004-438 100 (4x25) from 1 to 9 2004-439 100 (4x25) from 1 to 10 2004-440 100 (4x25)
Insulation stop, 5 pcs/strip, 0.25 ... 0.5 mm ² light gray 2002-171 200 (8x25)	Push-in type wire jumper, insulated, I _N 18 A, wire size 1.5 mm ² L = 60 mm 2009-412 100 (10x10) L = 110 mm 2009-414 100 (10x10) L = 250 mm 2009-416 100 (10x10)
Insulation stop, 5 pcs/strip, 0.75 ... 1 mm ² dark gray 2002-172 200 (8x25)	Protective warning marker, with high-voltage symbol, black, for 5 terminal blocks yellow 2002-115 100 (4x25)
Push-in type jumper bar, insulated, I _N 32 A, light gray 2-way 2004-402 200 (8x25) 3-way 2004-403 200 (8x25) 4-way 2004-404 100 (4x25) 5-way 2004-405 100 (4x25) 6-way 2004-406 100 (4x25) 7-way 2004-407 100 (4x25) 8-way 2004-408 100 (4x25) 9-way 2004-409 100 (4x25) 10-way 2004-410 100 (4x25)	Test plug, with 500 mm cable, 2 mm Ø red 210-136 50

When selecting miniature fuses, the maximum power loss listed below should not be exceeded. The power loss is determined according to IEC or EN 60947-7-3/VDE 0611-6 at 23°C. The temperature rise of the terminal blocks must be checked according to their application and mounting. Higher ambient temperatures are an additional burden on fuse cartridges. Therefore, in such applications the rated current must be reduced if necessary. More details available from the manufacturer.

TOPJOB® S

Disconnect and Ground Conductor Disconnect Terminal Blocks 6 (10) mm² / 30 A and Through Terminal Blocks of Same Profile, 2006 Series

0.5 ... 6 (10) mm ² ① 800 V/8 kV/3 ② I _N 30 A Terminal block width 7.5 mm / 0.295 in. □ 13 ... 15 mm / 0.55 in. ③	AWG 20 ... 8 600 V, 15 A ④ 600 V, 30 A ⑤	0.5 ... 6 (10) mm ² ① 800 V/8 kV/3 ② I _N 30 A Terminal block width 7.5 mm / 0.295 in. □ 13 ... 15 mm / 0.55 in. ③	AWG 20 ... 8 600 V, 30 A ④ 600 V, 30 A ⑤	0.5 ... 6 (10) mm ² ① 800 V/8 kV/3 ② I _N 30 A Terminal block width 15 mm / 0.591 in. □ 13 ... 15 mm / 0.55 in. ③	AWG 20 ... 8 600 V, 30 A ④ 600 V, 30 A ⑤
---	--	---	--	--	--

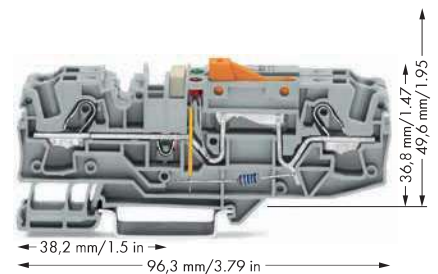
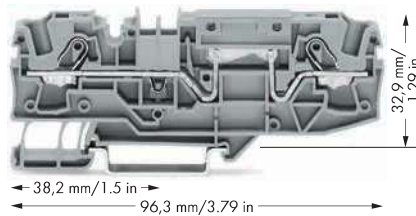
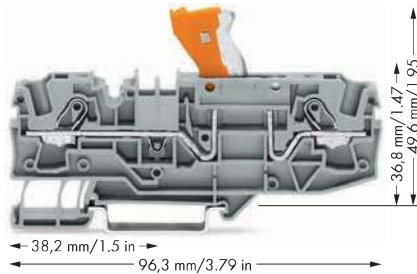

Item No.	Pack. Unit	Item No.	Pack. Unit	Item No.	Pack. Unit
2-conductor disconnect terminal block, with test point, orange disconnect link		2-conductor through terminal block, with test point, same profile as 2-conductor disconnect terminal block		Ground conductor disconnect terminal block, with test point, orange disconnect link, gray	
gray 2006-1671 25		gray 2006-1601 25		24 V 2006-1671/1000-848 12	
blue 2006-1674 25		blue 2006-1604 25		48 V 2006-1671/1000-849 12	
				120 V 2006-1671/1000-850 12	
				230 V 2006-1671/1000-851 12	
Other terminal blocks with the same profile:		Other terminal blocks with the same profile:		Other terminal blocks with the same profile:	
Through 2006-1601 Page 72		Carrier 2006-1661 Page 90		Through 2006-1601 Page 72	
Fuse 2006-1681 Page 74					
Item-Specific Accessories		Item-Specific Accessories		Item-Specific Accessories	
Push-in type jumper bar, insulated, I_N 41 A, light gray		Push-in type jumper bar, insulated, I_N 41 A, light gray		Push-in type jumper bar, insulated, I_N 41 A, light gray	
2-way 2006-402 50 (2x25)		2-way 2006-402 50 (2x25)		2-way 2006-402 50 (2x25)	
3-way 2006-403 50 (2x25)		3-way 2006-403 50 (2x25)		3-way 2006-403 50 (2x25)	
4-way 2006-404 50 (2x25)		4-way 2006-404 50 (2x25)		4-way 2006-404 50 (2x25)	
5-way 2006-405 50 (2x25)		5-way 2006-405 50 (2x25)		5-way 2006-405 50 (2x25)	
Push-in type jumper bar, insulated, I_N 41 A, light gray		Push-in type jumper bar, insulated, I_N 41 A, light gray		Push-in type jumper bar, insulated, I_N 41 A, light gray	
from 1 to 3 2006-433 50 (2x25)		from 1 to 3 2006-433 50 (2x25)		from 1 to 3 2006-433 50 (2x25)	
from 1 to 4 2006-434 50 (2x25)		from 1 to 4 2006-434 50 (2x25)		from 1 to 4 2006-434 50 (2x25)	
from 1 to 5 2006-435 50 (2x25)		from 1 to 5 2006-435 50 (2x25)		from 1 to 5 2006-435 50 (2x25)	
Star point jumper, insulated, I_N = I_N terminal block, light gray		Star point jumper, insulated, I_N = I_N terminal block, light gray		Star point jumper, insulated, I_N = I_N terminal block, light gray	
1-3-5 2006-405/011-000 50 (2x25)		1-3-5 2006-405/011-000 50 (2x25)		1-3-5 2006-405/011-000 50 (2x25)	

2006 Series Accessories

Appropriate marking systems: WMB/Marking strips

End and intermediate plate, 1 mm thick orange 2006-1692 100 (4x25) gray 2006-1691 100 (4x25)	Double-deck marker carrier, pivoting gray 2002-121 50 (2x25)	Screwless end stop, for DIN 35 rail, 6 mm wide gray 249-116 100 (4x25)
Protective warning marker, with high-voltage symbol, black, for 5 terminal blocks yellow 2006-115 100 (4x25)	WMB Multi marking system, 10 strips with 10 markers per card, stretchable 5 ... 5.2 mm plain 793-5501 5	Screwless end stop, for DIN 35 rail, 10 mm wide gray 249-117 50 (2x25)
	Marking strip, plain, 11 mm wide, 50 m roll white 2009-110 1	

Disconnect and Ground Conductor Disconnect Terminal Blocks

PUSH-IN CAGE CLAMP®



Ground conductor disconnect terminal block – top view

- 1 Conductor sizes: 0.5 mm² ... 10 mm² "s + f-st";
Push-in conductor sizes: 1 mm² ... 10 mm² "s"
and 1.5 mm² ... 6 mm²
"insulated ferrule, 12 mm"
- 2 800 V = rated voltage
8 kV = rated surge voltage
3 = pollution degree
(see Full Line Catalog, Volume 1, Section 14)
- 3 Strip length, see packaging or instructions.

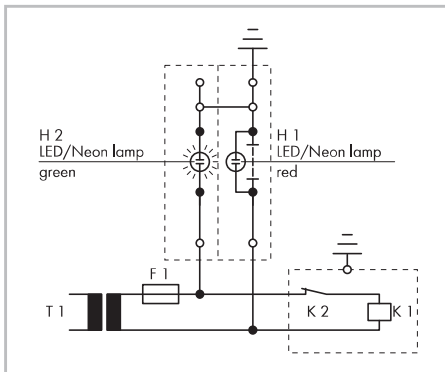

Operating condition
Slide link closed, auxiliary circuit grounded,
green lamp illuminates.

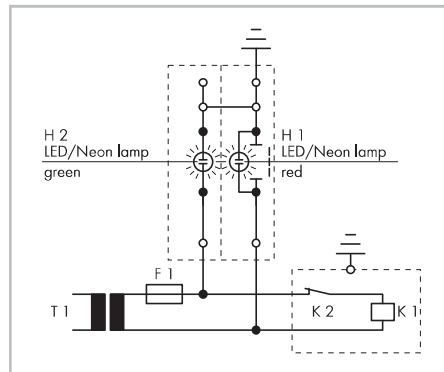

Test condition – no grounding
Slide link open, auxiliary circuit not grounded.

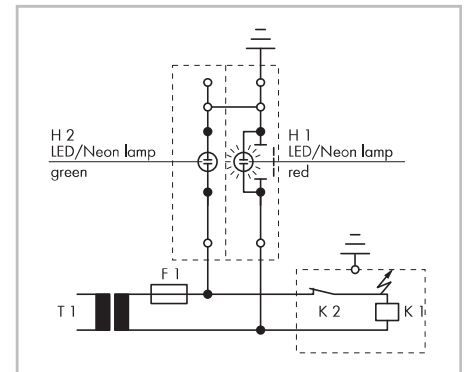

Test condition – grounding
Slide link open, auxiliary circuit not grounded,
red lamp illuminates.



Terminal block assembly including:
Through terminal blocks
N-conductor disconnect terminal blocks
Fuse terminal blocks for mini-automotive fuses

IEC 60204/DIN VDE 0113 "Electrical equipment of industrial machines, part 1: General requirements" 9.4.3.1:

Ground faults on control circuits shall not cause unintentional starting, hazardous movements or prevent stopping the machine.

In order to fulfill this requirement, bonding to the protective bonding circuit shall be provided in accordance with 8.2 and the devices shall be connected as described in 9.1.4. Control circuits fed from a transformer and not connected to the protective bonding circuit shall be provided with an insulation monitoring device (e.g., residual current device), which either indicates a ground fault or interrupts the circuit automatically after a ground fault.

In the case of electronic circuits, the connection of one side of the control circuit to the protective bonding circuit in accordance with 9.1.4 can prevent unintentional operation. When this does not help, or if due to other reasons electronic circuits cannot be connected to the protective bonding circuit, other measures shall be taken to achieve the same level of safety.

Multipole control switches which interrupt all live conductors shall be used where the control circuit is directly connected between the phase conductors of the supply or between a phase conductor and a neutral conductor, which is either not grounded or grounded through a high impedance. This is required for starting or stopping those machine functions, which can cause a hazardous situation including: damaging the machine or halting the work in progress, in the event of unintentional starting or failure to stop.

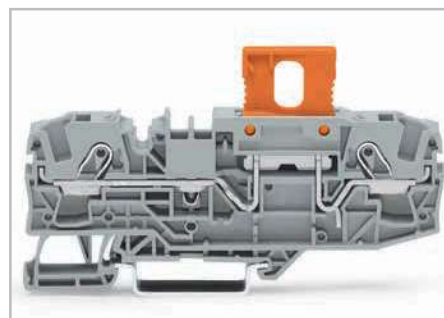

Carrier terminal block with disconnect plug in operating position.

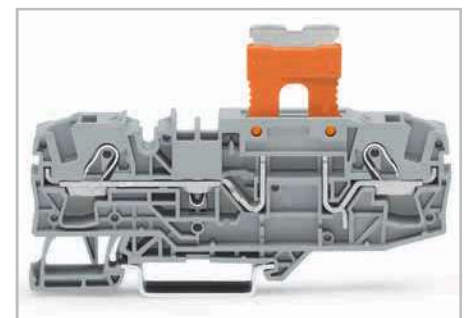

Carrier terminal block with disconnect plug in parked position.

TOPJOB® S

Fuse Terminal Blocks for Mini-Automotive Blade-Style Fuses 6 (10) mm² 2006 Series

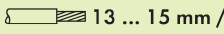
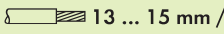
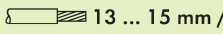
0.5 ... 6 (10) mm² ① 500 V/8 kV/3 ② I_N 25 A (30 A) ③ Terminal block width 7.5 mm / 0.295 in.  13 ... 15 mm / 0.55 in. ④	AWG 20 ... 8 12 V, 15 A ⑤ 12 V, 30 A ⑥	0.5 ... 6 (10) mm² ① 500 V/8 kV/3 ② I_N 25 A (30 A) ③ Terminal block width 7.5 mm / 0.295 in.  13 ... 15 mm / 0.55 in. ④	AWG 20 ... 8 24 V, 15 A ⑤ 24 V, 30 A ⑥	0.5 ... 6 (10) mm² ① 500 V/8 kV/3 ② I_N 25 A (30 A) ③ Terminal block width 7.5 mm / 0.295 in.  13 ... 15 mm / 0.55 in. ④	AWG 20 ... 8 48 V, 30 A ⑤ 48 V, 30 A ⑥
--	---	---	---	---	---

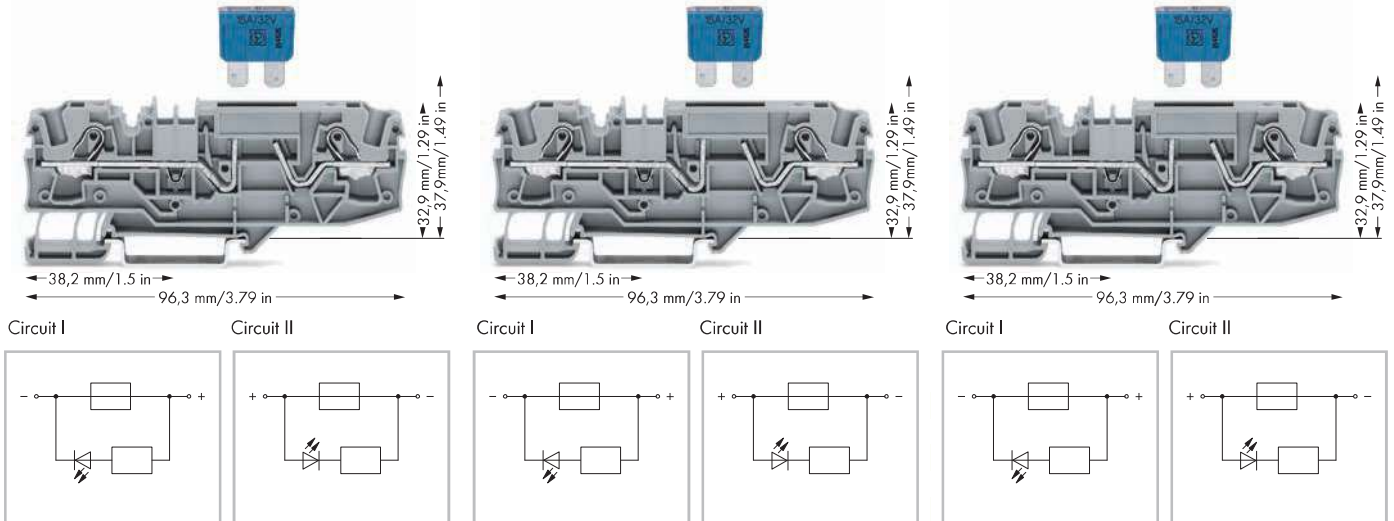

Item No.	Pack. Unit	Item No.	Pack. Unit	Item No.	Pack. Unit
2-conductor fuse terminal block for mini-automotive blade-style fuses,		2-conductor fuse terminal block for mini-automotive blade-style fuses,		2-conductor fuse terminal block for mini-automotive blade-style fuses,	
12V, with test point, with blown fuse indication by LED, LED power consumption: 4.8 mA, gray		24V, with test point, with blown fuse indication by LED, LED power consumption: 4.8 mA, gray		48V, with test point, with blown fuse indication by LED, LED power consumption: 4.8 mA, gray	
Both nominal voltage and current are given by the LED or fuse. Blade-style fuses, please note touchproof protection for 42V and higher.		Both nominal voltage and current are given by the LED or fuse. Blade-style fuses, please note touchproof protection for 42V and higher.		Both nominal voltage and current are given by the LED or fuse. Blade-style fuses, please note touchproof protection for 42V and higher.	
<input type="radio"/> Circuit I	2006-1681/1000-429 25	<input type="radio"/> Circuit I	2006-1681/1000-413 25	<input type="radio"/> Circuit I	2006-1681/1000-414 25
<input type="radio"/> Circuit II	2006-1681/1000-449 25	<input type="radio"/> Circuit II	2006-1681/1000-434 25	<input type="radio"/> Circuit II	2006-1681/1000-435 25
Other terminal blocks with the same profile:					
Through	2006-1601	Page 72			

2006 Series Accessories

Appropriate marking systems: WMB/Marking strips

End and intermediate plate, 1 mm thick orange 2006-1692 100 (4x25) gray 2006-1691 100 (4x25)	Protective warning marker, with high-voltage symbol, black, for 5 terminal blocks yellow 2006-115 100 (4x25)
Push-in type jumper bar, insulated, I _N 41 A, light gray 2-way 2006-402 50 (2x25) 3-way 2006-403 50 (2x25) 4-way 2006-404 50 (2x25) 5-way 2006-405 50 (2x25)	WMB Multi marking system, 10 strips with 10 markers per card, stretchable 5 ... 5.2 mm plain 793-5501 5 Marking strip, plain, 11 mm wide, 50 m roll white 2009-110 1
Push-in type jumper bar, insulated, I _N 41 A, light gray from 1 to 3 2006-433 50 (2x25) from 1 to 4 2006-434 50 (2x25) from 1 to 5 2006-435 50 (2x25)	Double-deck marker carrier, pivoting gray 2002-121 50 (2x25)

0.5 ... 6 (10) mm² ①
 500 V/8 kV/3 ②
 I_N 25 A (30 A) ③
 Terminal block width 7.5 mm / 0.295 in.
 13 ... 15 mm / 0.55 in. ④

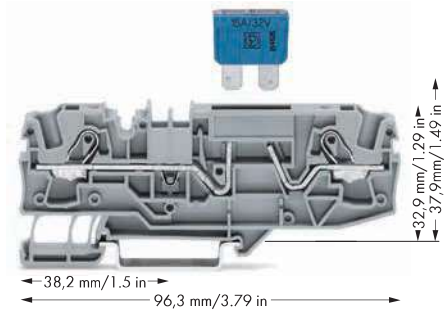
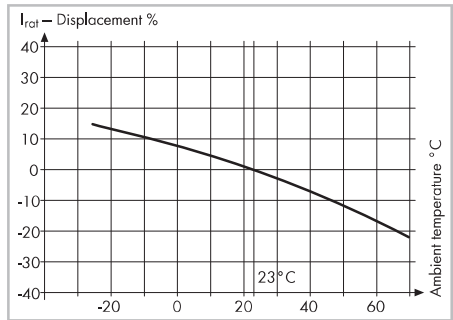

- ① Conductor sizes: 0.5 mm² ... 10 mm² "s + fst"; Push-in conductor sizes: 1 mm² ... 10 mm² "s" and 1.5 mm² ... 6 mm² "insulated ferrule, 12 mm"
- ② 500 V = rated voltage
8 kV = rated surge voltage
3 = pollution degree
(see Full Line Catalog, Volume 1, Section 14)
- ③ LED power consumption: 4.8 mA
- ④ Strip length, see packaging or instructions.

Item No.	Pack. Unit
2-conductor fuse terminal block for mini-automotive blade-style fuses,	
with test point,	
without blown fuse indication	
Both nominal voltage and current are given by the fuse.	
Blade-style fuses, please note touchproof protection for 42V and higher.	
gray	25
2006-1681	

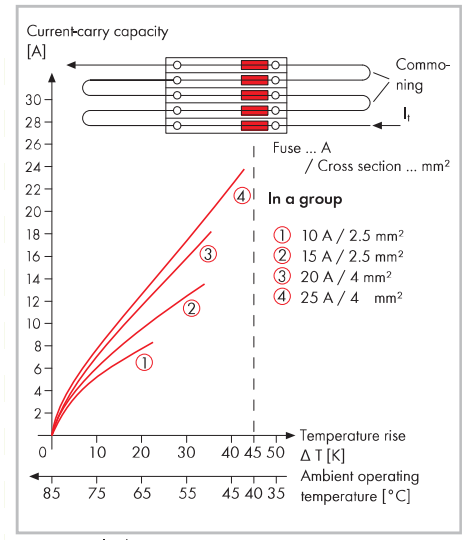
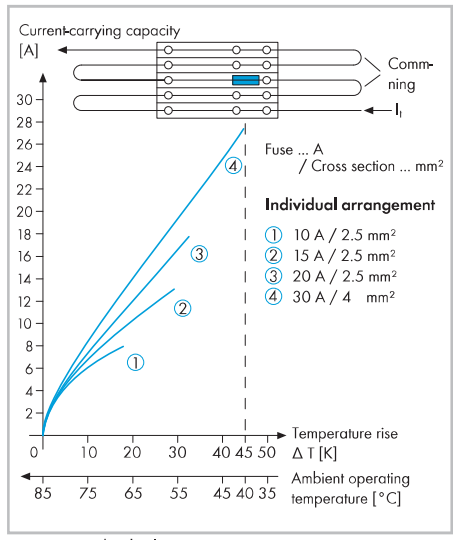

Diagram: Individual arrangement
 The rated currents of the fuse cartridges are defined differently in international standards. Due to the different current rating definitions, the recommended current-carrying permanent capacity of the fuses is max. 80% of their rated current according to DIN 72581 part 3 (for an ambient operating temperature of 23 °C).
 Selecting the correct fuse cartridge is important for product safety within applications, as well as for fuse cartridge service life and reliability. Fuse cartridges may be used as protection (break-off point) if they are properly selected and used according to manufacturer specifications.

Diagram: Block arrangement

Information from the mini-automotive blade-type fuse manufacturers

Derating T _{amb} / °C	%	F _T
- 25	14	0.877
- 20	13	0.885
- 15	12	0.893
- 10	11	0.901
- 5	10	0.909
0	9	0.917
5	8	0.926
10	6	0.943
15	4	0.962
20	2	0.980
23	0	1.000
30	- 2	1.020
35	- 4	1.042
40	- 6	1.064
45	- 8	1.087
50	- 10	1.111
55	- 13	1.149
60	- 16	1.190
65	- 19	1.235
70	- 22	1.282

Regarding product safety, it is in generally necessary to test fuse cartridges under normal conditions and operational failures within your application.

Fuse Disconnect Terminal Blocks with Pivoting Fuse Holder for Miniature Fuses 5 x 20 mm, 5 x 30 mm, 1/4" x 1 1/4", 2006 Series

0.5 ... 6 (10) mm ² ① 800 V/8 kV/3 ② I _N 10 A	AWG 20 ... 8 600 V, 15 A ^{VA} 600 V, 15 A [Ⓞ]	0.5 ... 6 (10) mm ² ① 800 V/8 kV/3 ② I _N 10 A	AWG 20 ... 8 30 V, 15 A ^{VA} 30 V, 15 A [Ⓞ]
Terminal block width 7.5 mm / 0.295 in. 13 ... 15 mm / 0.55 in. ③		Terminal block width 7.5 mm / 0.295 in. 13 ... 15 mm / 0.55 in. ③	

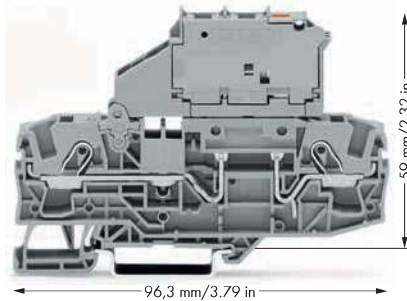
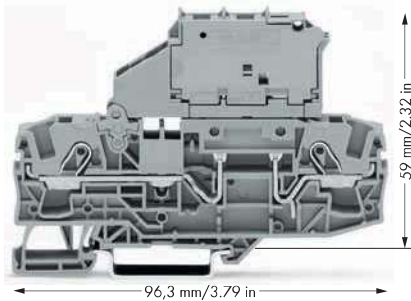

- ① Conductor sizes: 0.5 mm² ... 10 mm² "s + f-st"; Push-in conductor sizes: 1 mm² ... 10 mm² "s" and 1.5 mm² ... 6 mm² "insulated ferrule, 12 mm"
- ② 800 V = rated voltage
8 kV = rated surge voltage
3 = pollution degree
(see Full Line Catalog, Volume 1, Section 14)
- ③ Strip length, see packaging or instructions.
- ④ See application notes for: Star point jumper, page 165

Item No.	Pack. Unit	Item No.	Pack. Unit
2-conductor fuse disconnect terminal block with pivoting fuse holder, without blown fuse indication Both nominal voltage and current are given by the fuse, for miniature fuses 5 x 20 mm		2-conductor fuse disconnect terminal block with pivoting fuse holder, gray, with blown fuse indication by LED Both nominal voltage and current are given by the LED or fuse. Leakage current in case of blown fuse: LED 2mA, for miniature fuses 5 x 20 mm	
○ gray	2006-1611	25	○ 12 ... 30 V 2006-1611/1000-541 25 ○ 30 ... 65 V 2006-1611/1000-542 25 ○ 120 V 2006-1611/1000-867 25 ○ 230 V 2006-1611/1000-836 25
for miniature fuses 5 x 30 mm		for miniature fuses 5 x 30 mm	
○ gray	2006-1621	25	○ 12 ... 30 V 2006-1621/1000-541 25 ○ 30 ... 65 V 2006-1621/1000-542 25 ○ 120 V 2006-1621/1000-867 25 ○ 230 V 2006-1621/1000-836 25 ○ 380 ... 500 V 2006-1621/1000-859 25
for miniature fuses 1/4" x 1 1/4"		for miniature fuses 1/4" x 1 1/4"	
○ gray	2006-1631	25	○ 12 ... 30 V 2006-1631/1000-541 25 ○ 30 ... 65 V 2006-1631/1000-542 25 ○ 120 V 2006-1631/1000-867 25 ○ 230 V 2006-1631/1000-836 25 ○ 380 ... 500 V 2006-1631/1000-859 25



Pivoting the fuse holder in the locked open position.

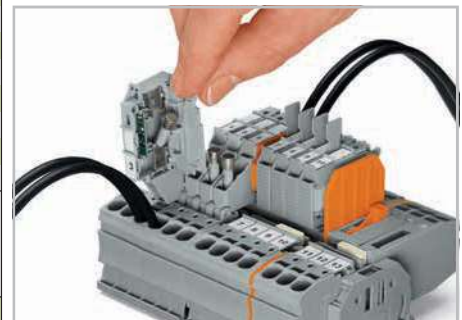

Opening the cover to replace the fuse.

2006 Series Accessories

Appropriate marking systems: WMB/Marking strips

End and intermediate plate, 1 mm thick orange 2006-1692 100 (4x25) gray 2006-1691 100 (4x25)	Push-in type jumper bar, insulated, I _N 41 A, light gray from 1 to 3 2006-433 50 (2x25) from 1 to 4 2006-434 50 (2x25) from 1 to 5 2006-435 50 (2x25)
End plate for fuse terminal blocks, 2 mm thick orange 2006-992 100 (4x25) gray 2006-991 100 (4x25)	Protective warning marker, with high-voltage symbol, black, for 5 terminal blocks yellow 2006-115 100 (4x25)
Push-in type jumper bar, insulated, I _N 41 A, light gray 2-way 2006-402 50 (2x25) 3-way 2006-403 50 (2x25) 4-way 2006-404 50 (2x25) 5-way 2006-405 50 (2x25)	Test plug, with 500 mm cable, 2 mm Ø red 210-136 50
Star point jumper, insulated, I _N = I _N terminal block, light gray 1-3-5 2006-405/011-000 50 (2x25)	WMB Multi marking system, 10 strips with 10 markers per card, stretchable 5 ... 5.2 mm plain 793-5501 5

Fuse Disconnect Terminal Blocks with Pivoting Fuse Holder for Miniature Fuses 1/4" x 1 1/4", 2006 Series

0.5 ... 6 (10) mm ² ① 800 V/8 kV/3 ② I _N 10 A Terminal block width 10.4 mm / 0.409 in. 13 ... 15 mm / 0.55 in. ③	AWG 20 ... 8 600 V, 15 A ④ 600 V, 15 A ④	0.5 ... 6 (10) mm ² ① 800 V/8 kV/3 ② I _N 10 A Terminal block width 10.4 mm / 0.409 in. 13 ... 15 mm / 0.55 in. ③	AWG 20 ... 8 30 V, 15 A ④ 30 V, 15 A ④
--	--	--	--

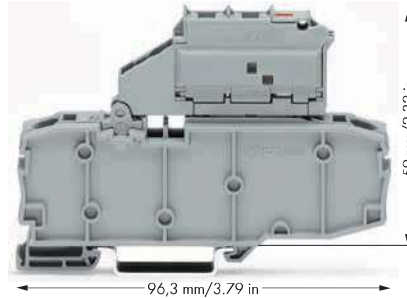
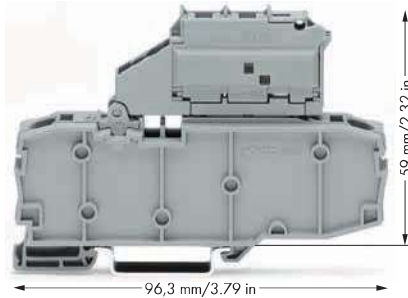

- ① Conductor sizes: 0.5 mm² ... 10 mm² "s + f-st"; Push-in conductor sizes: 1 mm² ... 10 mm² "s" and 1.5 mm² ... 6 mm² "insulated ferrule, 1.2 mm"
- ② 800 V = rated voltage
8 kV = rated surge voltage
3 = pollution degree
(see Full Line Catalog, Volume 1, Section 14)
- ③ Strip length, see packaging or instructions.
- ④ See application notes for: Star point jumper, page 165

Item No.	Pack. Unit	Item No.	Pack. Unit
Fuse disconnect terminal block with pivoting fuse holder and end plate, without blown fuse indication Both nominal voltage and current are given by the fuse. for miniature fuses 1/4" x 1 1/4"		Fuse disconnect terminal block with pivoting fuse holder and end plate, gray, with blown fuse indication by LED Both nominal voltage and current are given by the LED or fuse. Leakage current in case of blown fuse: LED 2mA, for miniature fuses 1/4" x 1 1/4"	
○ gray	2006-1631/099-000 25	○ 12 ... 30 V	2006-1631/1099-541 25
		○ 30 ... 65 V	2006-1631/1099-542 25
		○ 120 V	2006-1631/1099-867 25
		○ 230 V	2006-1631/1099-836 25
		○ 380 ... 500 V	2006-1631/1099-859 25



Pivoting fuse holder with spare fuse holders

Protective warning markers must be applied individually. Due to the 10.4 mm width of the fuse terminal blocks with pivoting fuse holder, 2002 Series jumpers must be used.

2006 Series Accessories

Appropriate marking systems: WMB/Marking strips

End plate for fuse terminal blocks, 2 mm thick orange 2006-992 100 (4x25) gray 2006-991 100 (4x25)	Screwless end stop, for DIN 35 rail, 6 mm wide gray 249-116 100 (4x25)
Push-in type jumper bar, insulated, I _N 25 A, light gray from 1 to 3 2002-433 200 (8x25) from 1 to 5 2002-435 100 (4x25) from 1 to 7 2002-437 100 (4x25) from 1 to 9 2002-439 100 (4x25)	Screwless end stop, for DIN 35 rail, 10 mm wide gray 249-117 50 (2x25)
Star point jumper, insulated, ④ I _N = I _N terminal block, light gray 1-3-5 2002-405/011-000 100 (4x25)	
Protective warning marker, with high-voltage symbol, black, for 5 terminal blocks yellow 2006-115 100 (4x25)	
WMB Multi marking system, 10 strips with 10 markers per card, stretchable 5 ... 5.2 mm plain 793-5501 5	
Test plug, with 500 mm cable, 2 mm Ø red 210-136 50	

Miniature fuses

Series Item No.	Overload and short circuit protection		Short circuit protection only	
	Individual argmt.	Group argmt.	Individual argmt.	Group argmt.
Fused disconnect terminal blocks				
2006-1611	7.5	1.6 W	1.6 W	2.5 W
2006-1621	7.5	1.6 W	1.6 W	2.5 W
2006-1631	7.5	1.6 W	1.6 W	2.5 W
2006-1631 /099...	10.4	2.5 W	2.5 W	2.5 W
2006-1631 /1099...	10.4	2.5 W	2.5 W	2.5 W

When selecting miniature fuses, the maximum power loss listed below should not be exceeded. The power loss is determined according to IEC or EN 60947-7-3/VDE 0611-6 at 23 °C. The temperature rise of the terminal blocks must be checked according to their application and mounting. Higher ambient temperatures represent an additional impact on miniature fuses. Therefore, in such applications the rated current must be reduced if necessary. More details are available from the fuse manufacturer.

TOPJOB® S

Disconnect Terminal Blocks for Test and Measurement 1500 VDC, Carrier/Through Terminal Blocks of Same Profile 6 (10) mm²/30 A, 2006 Series



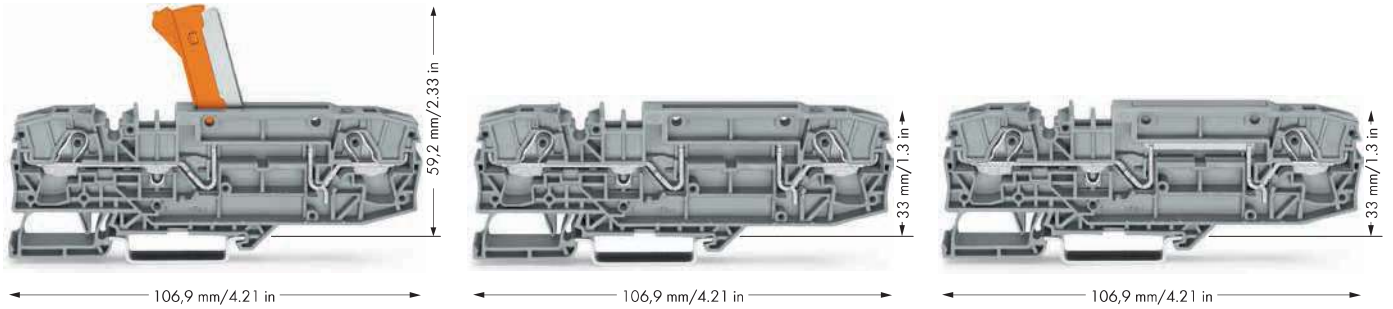





0.5 ... 6 (10) mm ² ① AWG 20 ... 8 AC/DC 1000 V/ DC 1500 V/12 kV/3 ② I _N 30 A 600 V, 30 A ③, 1000 V, 30 A ④ Terminal block width 15 mm / 0.591 in. 13 ... 15 mm / 0.55 in. ⑤	0.5 ... 6 (10) mm ² ① AWG 20 ... 8 AC/DC 1000 V/ DC 1500 V/12 kV/3 ② I _N 30 A 600 V, 30 A ③, 1000 V, 30 A ④ Terminal block width 15 mm / 0.591 in. 13 ... 15 mm / 0.55 in. ⑤	0.5 ... 6 (10) mm ² ① AWG 20 ... 8 AC/DC 1000 V/ DC 1500 V/12 kV/3 ② I _N 30 A 600 V, 30 A ③, 1000 V, 30 A ④ Terminal block width 15 mm / 0.591 in. 13 ... 15 mm / 0.55 in. ⑤
--	--	--



Item No.	Pack. Unit	Item No.	Pack. Unit	Item No.	Pack. Unit
2-conductor disconnect terminal block for test and measurement, with test point, orange disconnect link		2-conductor carrier terminal block, with test point		2-conductor through terminal block, with test point, same profile as 2-conductor disconnect terminal block	
gray 2006-8671	12	gray 2006-8661	12	gray 2006-8601	12
blue 2006-8674	12	blue 2006-8664	12	blue 2006-8604	12
Item-Specific Accessories					
 Disconnect plug for carrier terminal blocks, suited when using a carrier terminal block as disconnect terminal block orange 2006-8401 48 (4x12)					

2006 Series Accessories

Appropriate marking systems: WMB/Marking strips

End and intermediate plate, 1 mm thick  orange 2006-8692 48 (4x12)  gray 2006-8691 48 (4x12)	WMB Multi marking system, 10 strips with 10 markers per card, for terminal widths 5 ... 17.5 mm  plain 793-501 5
Protective warning marker, ④ with high-voltage symbol, black, for 5 terminal blocks  yellow 2006-115 100 (4x25)	WMB Multi marking system, plain, 10 strips with 10 markers per card, for terminal widths 5 ... 17.5 mm  yellow 793-501/000-002 red 793-501/000-005 blue 793-501/000-006 gray 793-501/000-007 orange 793-501/000-012 light green 793-501/000-017 green 793-501/000-023 violet 793-501/000-024 5
Push-in type jumper bar, insulated, I _N 41 A, light gray  from 1 to 3 2006-433 50 (2x25) from 1 to 5 2006-435 50 (2x25)	Marking strip, plain, 11 mm wide, 50 m roll  white 2009-110 1
Lockout cap, for conductor entry hole and operating slot  gray 2006-191 25	WMB Inline, plain, stretchable 5 ... 5.2 mm, 1,500 WMB markers, 5 mm, on roll  white 2009-115 1



Disconnect/test terminal block with knife disconnect (2006-8671) in disconnect position

Both 2006-8671 and 2006-8661 TOPJOB® S disconnect terminal blocks have been specially designed for use in photovoltaic and wind power systems, where voltages exceeding 1,000 V (IEC) and 600 V (UL) are required (e.g., generator junction boxes).

- Ideal for high voltages in renewable energy applications
- **Disconnect terminal blocks with two alternative disconnect options:
with orange knife disconnect (2006-8671)
with orange disconnect plug (2006-8661)**
- This 2006 Series terminal blocks are approved for 30 A/1,500 VDC (IEC) or 1,000 VDC (UL)
- With a terminal block width of 15 mm, the maximum cross-section for solid and fine-stranded conductors is 10 mm² (AWG 8) and 6 mm² (AWG 10) for ferruled conductors.
- Equipped with test slots
- Compatible with through terminal blocks of the same profile and all other TOPJOB® S terminal blocks

① Conductor sizes: 0.5 mm² ... 10 mm² "s + f-st";
Push-in conductor sizes: 1 mm² ... 10 mm² "s"
and 1.5 mm² ... 6 mm²
"insulated ferrule, 12 mm"

② AC/DC 1000 V = rated voltage
DC 1500 V
12 kV = rated surge voltage
3 = pollution degree

(see Full Line Catalog, Volume 1, Section 14)

③ Strip length, see packaging or instructions.

④ Protective warning marker must be applied individually.

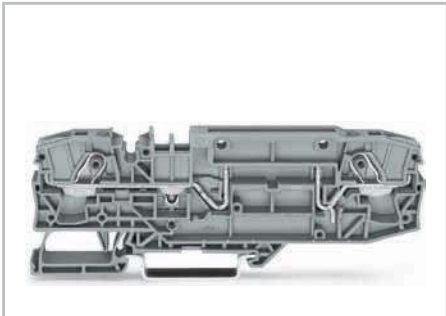

Carrier terminal block (2006-8661) with receptacle for orange disconnect plug

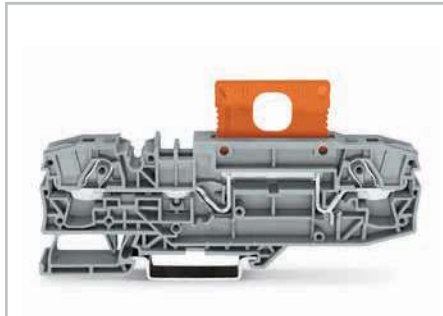

Orange disconnect plug (2006-8401) in operating position

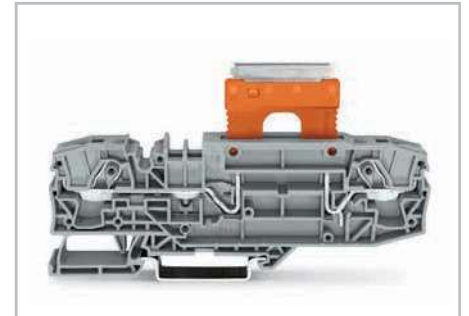

Orange disconnect plug (2006-8401) in parked position

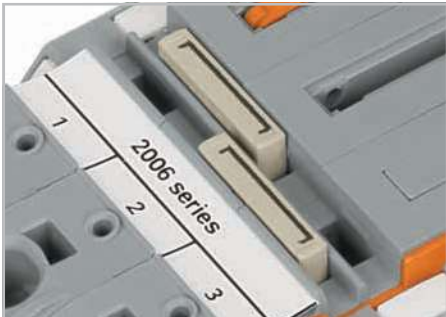

Commoning a 15 mm wide terminal block via push-in type jumper bars: 1 to 3 (2006-433) and 1 to 5 (2006-435).

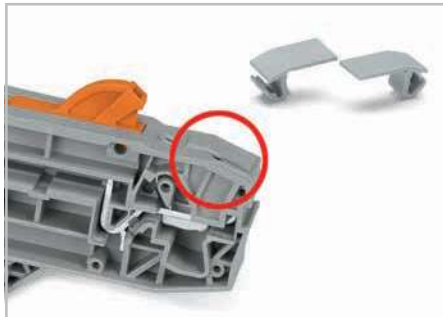

Cover seals unused conductor entry.



Alternatively, measurement can also be performed using TOPJOB® S connectors (2006-511) from terminal block 1 to 2. Spacer modules (2006-549) must be used to compensate for the 15 mm terminal block width.

TOPJOB® S 2007-8821 Current Transformer Terminal Blocks (Orange Disconnect Link)

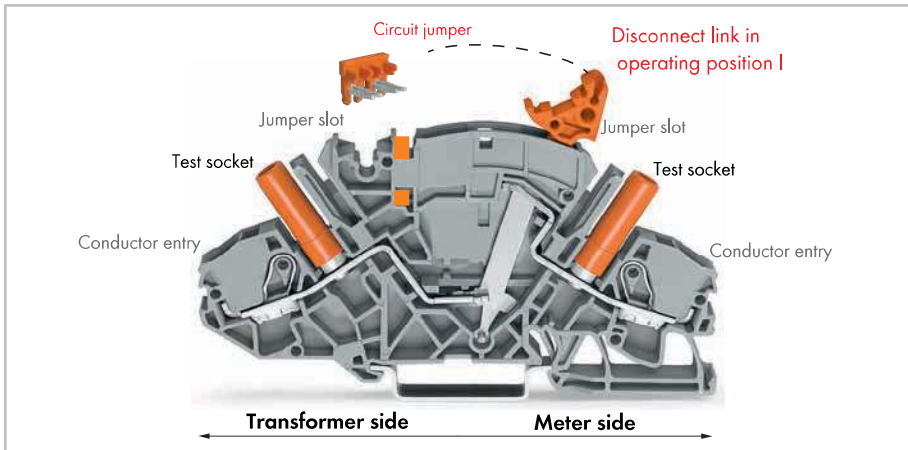

The TOPJOB® S current transformer (disconnect/test) terminal block (2007-8821) has been specially designed for current and voltage transformer circuits to measure the current transformer's operability.

First, the current transformer is shorted via disconnect link and circuit jumper (insert jumper, move disconnect link from operation position I to shorting position II, activate shorting path). Connecting a measuring device via test socket on the meter side can only be performed once circuit disconnection is complete (disconnect link in measuring position III).

- Features top-of-unit circuit jumper slot for shorting path activation.
- Disconnect link provides intuitive and easy operation, as well as exact switching status indication.
- Combines high functionality with compact design (99.6 mm long and 8 mm wide).
- All 2007 Series terminal blocks are rated 30 A/500 V (IEC) and 300 V (UL).
- With a terminal block width of 8 mm, the maximum cross-section for solid and fine-stranded conductors is 10 mm² (AWG 8) and 6 mm² (AWG 10) for ferruled conductors.
- Touch-proof test sockets for 4 mm Ø test plugs on transformer and meter side.
- Compatible with through and ground conductor terminal blocks of same profile.

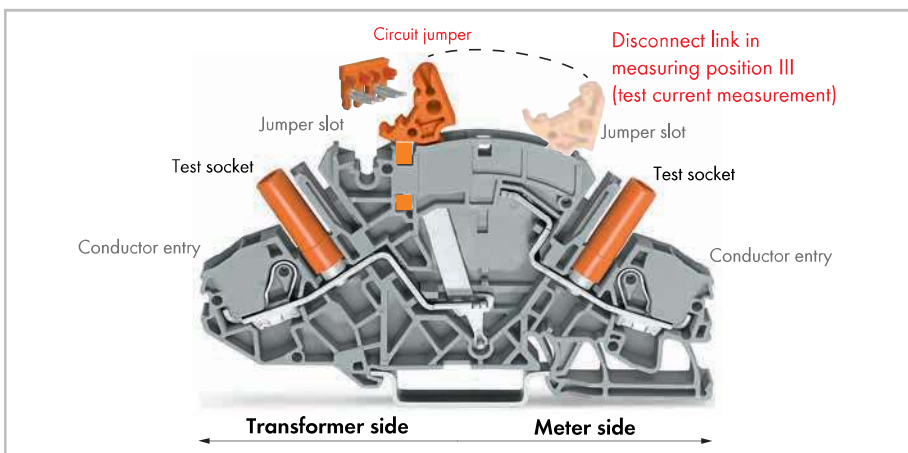
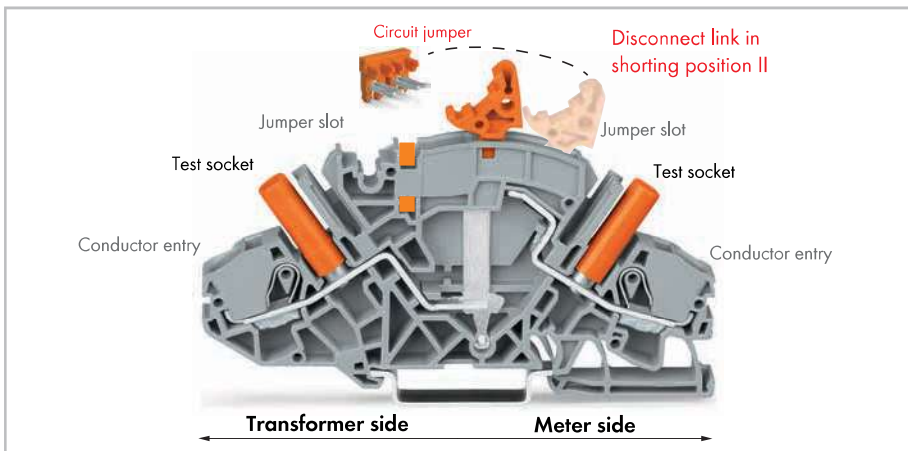

Preparing the shorting path for current transformer circuits

Inserting insulated, touch-proof circuit jumpers into jumper slot. Using locking covers or profiles for adjacent terminal blocks allows disconnect links to be operated simultaneously.

TOPJOB® S

Implementing a Current and Voltage Transformer Circuit

Disconnect link in operating position I



Terminal blocks required:
 2 x disconnect/test terminal block 2007-8821
 1 x circuit jumper, orange 2007-8442
 optional with locking covers or interlocking links

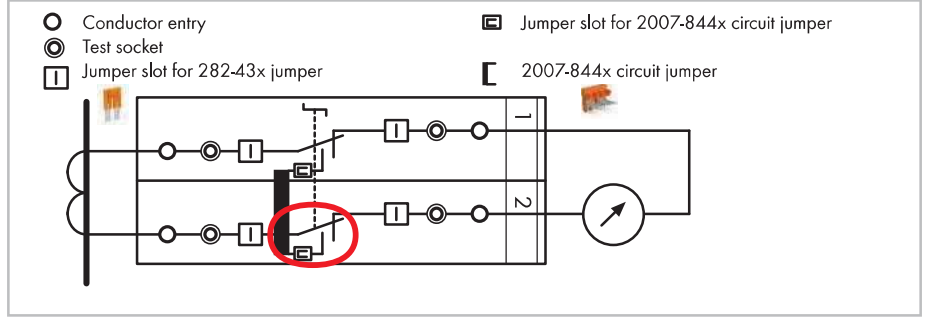

In operating position, the measuring device is connected to the transformer, the circuit jumper is inserted and the disconnect link is in position I.

Disconnect link in shorting position II

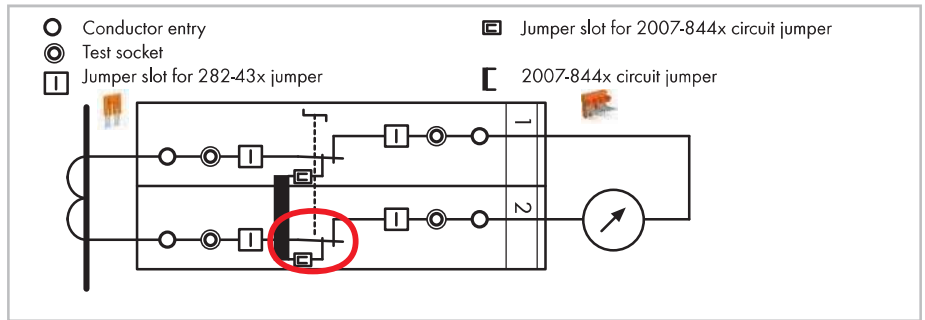

The transformer is **not** disconnected from the measuring device yet, the shorting path is activated by moving the disconnect link into shorting position II and the transformer is safely shorted.

Measuring, disconnect link in measuring position III / test current measurement

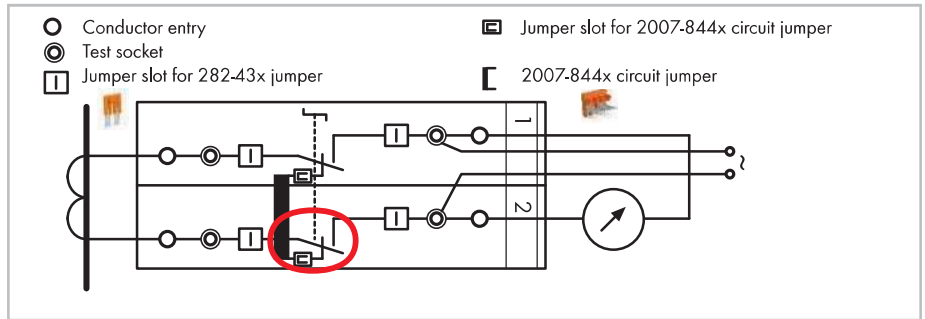

The measuring device/relay is electrically disconnected from the transformer. If required, an external voltage can be applied to the measuring device/relay via the test socket.

Measurement testing via both test sockets



Terminal block 1: Disconnect link in operating position I
 Terminal block 2: Disconnect link in measuring position III

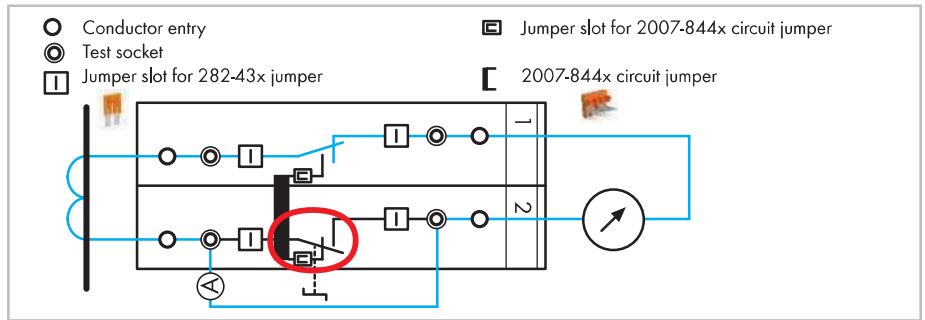

Measurement testing: First insert the reference current meter (A) into the test socket, then move the disconnect link into measurement position III (test current measurement).

Examples for Current Transformer Circuits

Measuring set for a 3-phase current transformer



Terminal blocks required:
 6 x disconnect/test terminal block 2007-8821
 3 x circuit jumper, orange 2007-8442
 In addition: interlocking links, locking covers, lock-outs

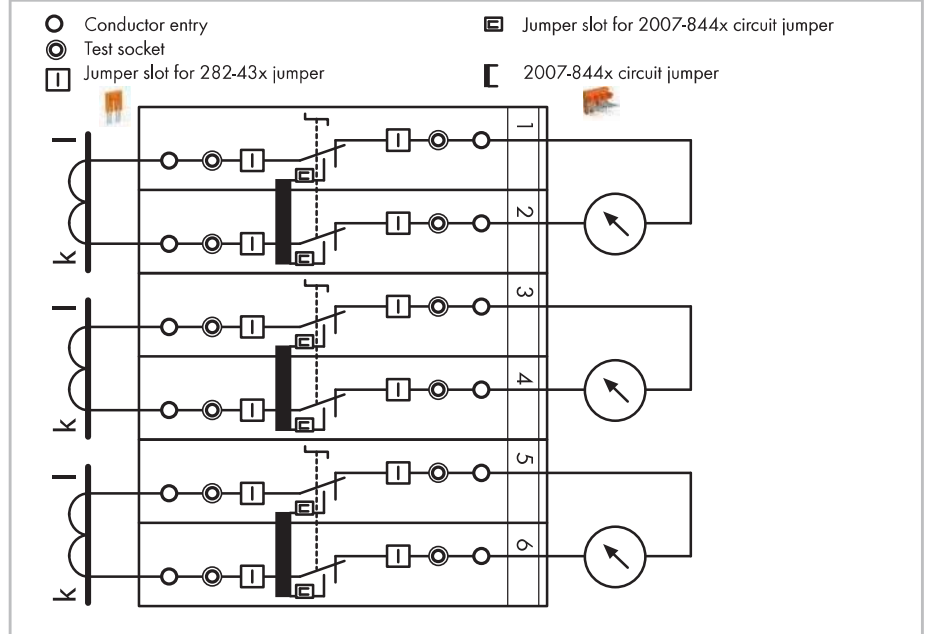

Pairs of disconnect links are interconnected via locking covers or interlocking links. Measurement testing is performed after the interlocking is released.

Measuring set for a 3-phase current transformer with 'Y' point



Terminal blocks required:
 6 x disconnect/test terminal block 2007-8821
 1 x circuit jumper, orange 2007-8446
 1 x jumper, orange 282-433
 In addition: interlocking links, locking covers, lock-outs

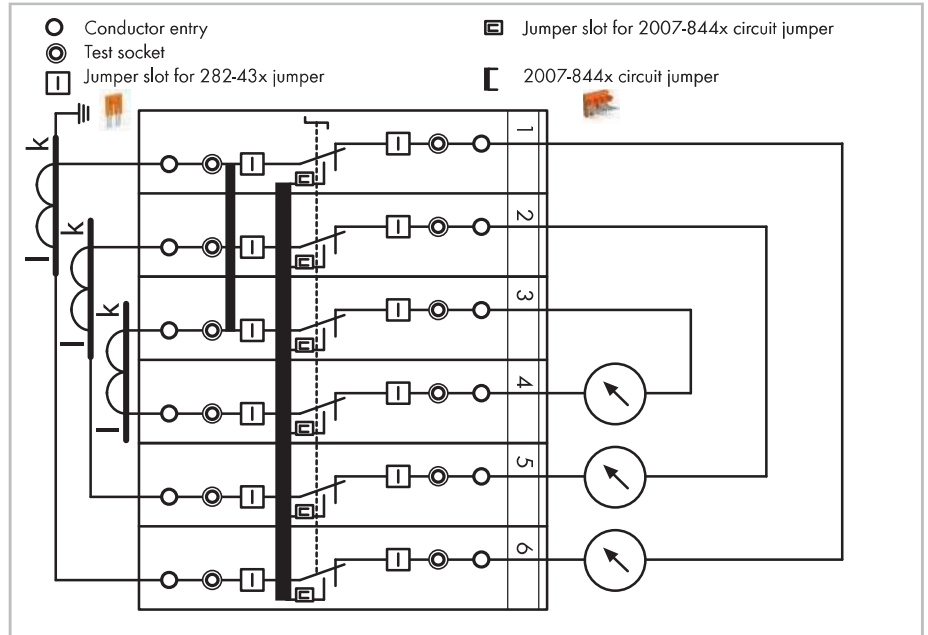

All 6 disconnect links are interconnected via via locking covers or interlocking links.

TOPJOB® S 2007-8811 Voltage Transformer Terminal Blocks (Light Gray Disconnect Link)

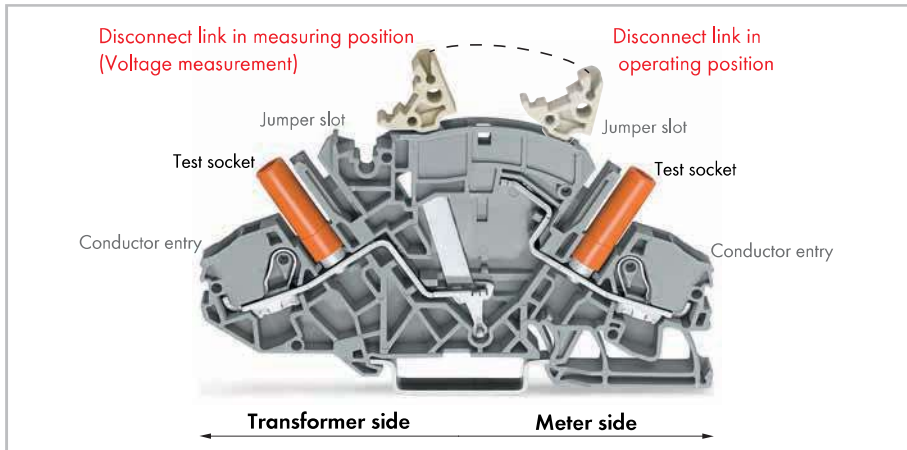

The TOPJOB® S voltage transformer (disconnect/test) terminal block (2007-8811) has been specially designed for voltage transformer circuits.

First, the voltage transformer must be disconnected from the circuit (from operating position to measuring position). Connecting a measuring device via test socket on the meter side can only be performed once circuit disconnection is completed (measuring position).

- For voltage transformer circuits (no circuit jumper slot required as for current transformer terminal block 2007-8821).
- Disconnect link provides intuitive and easy operation, as well as exact switching status indication.
- Combines high functionality with compact design (99.6 mm long and 8 mm wide).
- All 2007 Series terminal blocks are rated at 30 A/500 V (IEC) and 300 V (UL).
- With a terminal block width of 8 mm, the maximum cross-section for solid and fine-stranded conductors is 10 mm² (AWG 8) and 6 mm² (AWG 10) for ferruled conductors.
- Touch-proof test sockets for 4 mm Ø test plugs on transformer and meter side.
- Compatible with through and ground conductor terminal blocks of same profile.

Example for voltage transformer testing Measuring set for single-phase voltage transformer testing



Terminal blocks required:
 1 x disconnect/test terminal block 2007-8811
 1 x through terminal block 2007-8801
 1 x end plate, orange 2007-8892
 In addition: locking cover, lock-out

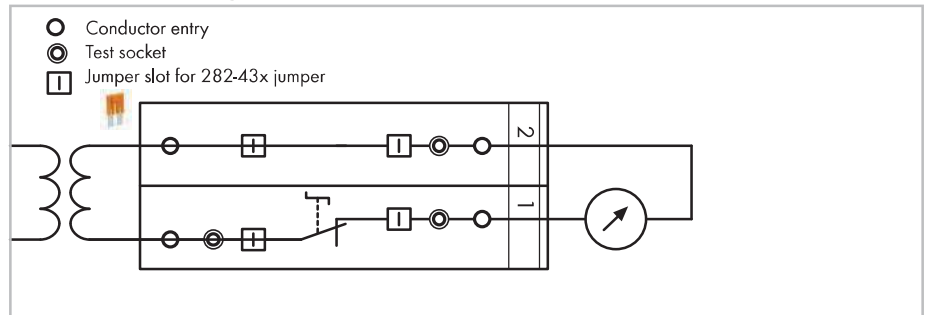

Disconnecting the voltage transformer from the circuit: Move disconnect link from operating position to measuring position.
 Voltage measurement: Connecting a measuring device via test socket on the meter side can only be performed after disconnection is completed (measuring position).

Marking



Marking via WMB Multi markers or marking strips.

Commoning



Additional commoning option via circuit-related jumpers or testing via test plug adapters (209-170) on transformer side

Locking cover for disconnect links





Multipole switching via snap-on type, transparent (locking) cover for disconnect links.

TOPJOB® S

Disconnect Terminal Blocks for Test and Measurement, 6 mm²/30 A, for Current and Voltage Transformer Circuits, 2007 Series

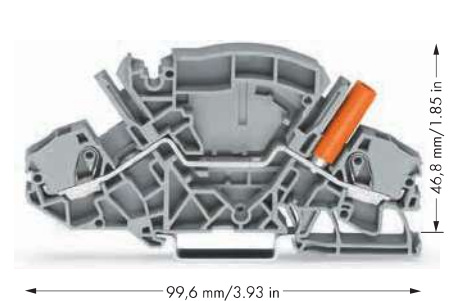
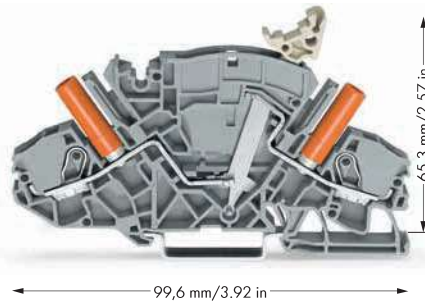
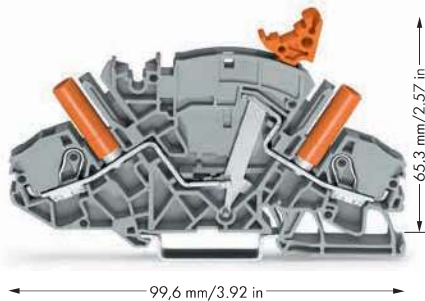
0.5 ... 6 (10) mm ² ① 500 V/6 kV/3 ② I _N 30 A Terminal block width 8 mm / 0.315 in. 13 ... 15 mm / 0.55 in. ③	AWG 20 ... 8 300 V, 30 A ④	0.5 ... 6 (10) mm ² ① 500 V/6 kV/3 ② I _N 30 A Terminal block width 8 mm / 0.315 in. 13 ... 15 mm / 0.55 in. ③	AWG 20 ... 8 300 V, 10 A ④	0.5 ... 6 (10) mm ² ① 500 V/6 kV/3 ② I _N 30 A Terminal block width 8 mm / 0.315 in. 13 ... 15 mm / 0.55 in. ③	AWG 20 ... 8 300 V, 30 A ④
---	-------------------------------	---	-------------------------------	---	-------------------------------



Item No.	Pack. Unit	Item No.	Pack. Unit	Item No.	Pack. Unit
2-conductor disconnect terminal block for test and measurement , e.g., current transformer circuits, with receptacle for adjacent jumper with switch lever, with touch-proof test sockets, for 4 mm Ø test plug		2-conductor disconnect terminal block for test and measurement , e.g., voltage transformer circuits, with touch-proof test sockets, for 4 mm Ø test plug		2-conductor through terminal block , with touch-proof test socket, for 4 mm Ø test plug	
● gray 2007-8821	20	● gray 2007-8811	20	● gray 2007-8801	20
Item-Specific Accessories					
Adjacent jumper for switch lever , insulated, orange, I _N 30 A					
	2-way 2007-8442	50 (5x10)			
	3-way 2007-8443	50 (5x10)			
	4-way 2007-8444	50 (5x10)			
	5-way 2007-8445	50 (5x10)			
	6-way 2007-8446	50 (5x10)			
	7-way 2007-8447	50 (5x10)			
	8-way 2007-8448	50 (5x10)			

2006 Series Accessories

Appropriate marking systems: WMB/Marking strips

End and separator plate , 1.5 mm thick, without use of lock-out seal	Jumper , insulated, I _N 30 A, orange	Jumper , special design, I _N 30 A, orange
orange 2007-8892 50 (5x10)	2-way 282-432 50 (5x10)	1-3-5 282-435/011-000
gray 2007-8891 50 (5x10)	3-way 282-433 50 (5x10)	1-2-4-6 282-436/301-000
End and separator plate , 1.5 mm thick, for use of lock-out seal	4-way 282-434 50 (5x10)	1-3-5-7 282-437/011-000
orange 2007-8894 50 (5x10)	5-way 282-435 50 (5x10)	1-4-7 282-437/012-000
gray 2007-8893 50 (5x10)	6-way 282-436 50 (5x10)	1-2-5-8 282-438/300-000
Lock-out , for disconnect link	7-way 282-437 50 (5x10)	1-4-7-8 282-438/301-000
yellow 2007-8899 100 (5x20)	8-way 282-438 50 (5x10)	1-3-5-7-9 282-439/011-000 50 (5x10)
Locking cover , transparent, mechanically locks multiple links	Jumper with safety lid , insulated, I _N 30 A, orange	Protective warning marker , with high-voltage symbol, black, for 5 terminal blocks
1-pole 282-881 50 (5x10)	2-way 282-432/100-000	yellow 2006-115 100 (4x25)
2-pole 282-882 50 (5x10)	3-way 282-433/100-000	WMB Multi marking system , 10 strips with 10 markers per card, for terminal widths 5 ... 17.5 mm
3-pole 282-883 50 (5x10)	4-way 282-434/100-000 50 (5x10)	plain 793-501 5
4-pole 282-884 50 (5x10)		Marking strip , plain, 11 mm wide, 50 m roll
5-pole 282-885 50 (5x10)	Interlocking link , mechanically locks multiple links, 1 m/3'3" long	white 2009-110 1
6-pole 282-886 50 (5x10)	transparent 210-254 1	
7-pole 282-887 50 (5x10)		
8-pole 282-888 50 (5x10)		

Approvals see www.wago.com



0.5 ... 6 (10) mm² ① | AWG 20 ... 8

Terminal block width 8 mm / 0.315 in.
 13 ... 15 mm / 0.55 in. ③



The terminal blocks feature integrated test sockets for touch-proof 4 mm Ø test plugs.

- ① Conductor sizes: 0.5 mm² ... 10 mm² "s + f-st";
 Push-in conductor sizes: 1 mm² ... 10 mm² "s"
 and 1.5 mm² ... 6 mm²
 "insulated ferrule, 12 mm"
- ② 500 V = rated voltage
 6 kV = rated surge voltage
 3 = pollution degree
 (see Full Line Catalog, Volume 1, Section 14)
- ③ Strip length, see packaging or instructions.

Item No.	Pack. Unit
2-conductor ground terminal block, with touch-proof test socket, for 4 mm Ø test plug	
 green-yellow	2007-8807 20
WMB Multi marking system, 10 strips with 10 markers per card, for terminal widths 5 ... 17.5 mm, yellow	
 k/1 (50x)	794-5553/000-002 5
WMB Multi marking system, 10 strips with 10 markers per card, for terminal widths 5 ... 17.5 mm, blue	
 U/V (50x)	794-5554/000-006 5



Lock-out prevents accidental operation of disconnect link.



Lock-out snaps into one of two notched positions.



Interlocking link for mechanical interlocking of several links for multi-pole switching



A lock-out seal can be used on the disconnect link in operating position I in connection with end and separator plate (2007-8893 or 2007-8894)

TOPJOB® S

Terminal Block Assemblies for Current and Voltage Transformers

2007 Series



Item No. for 2007-8873	Description	Quantity
249-117	Screwless end stop, 10 mm wide	2
282-882	Locking cover, mechanically locks multiple links, 2-pole	3
282-884	Locking cover, mechanically locks multiple links, 4-pole	1
2007-8442	Adjacent jumper for switch lever, insulated, 2-way	3
2007-8807	2-conductor ground terminal block, with touch-proof test socket, for 4 mm Ø test plug	1
2007-8811	2-conductor disconnect terminal block for test and measurement, with touch-proof test sockets, for 4 mm Ø test plug	4
2007-8821	2-conductor disconnect terminal block for test and measurement, with touch-proof test sockets, for 4 mm Ø test plug	6
2007-8892	End and separator plate, 1.5 mm thick, without use of lock-out seal	2
2009-115	WMB Inline, plain, 1,500 WMB markers, 5 mm, on roll	21 Markers
282-435/011-000	Jumper, insulated, 1-3-5	1
Assembly width incl. end stop		11.2 cm

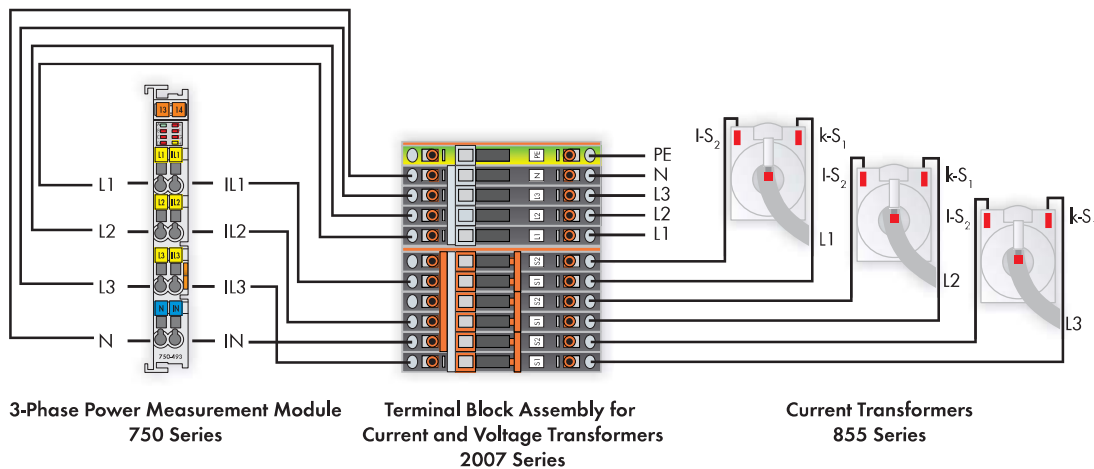



Item No. for 2007-8876	Quantity
Description	
249-117 Screwless end stop, 10 mm wide	2
282-369 Collective carrier for jumpers, for DIN 35 rail, for jumpers for transverse switching terminal block (282-811) and longitudinal switching disconnect terminal block (282-821)	1
282-882 Locking cover, mechanically locks multiple links, 2-pole	3
2007-8442 Adjacent jumper for switch lever, insulated, 2-way	3
2007-8821 2-conductor disconnect terminal block for test and measurement, with touch-proof test sockets, for 4 mm Ø test plug	6
2007-8892 End and separator plate, 1.5 mm thick, without use of lock-out seal	1
2009-115 WMB Inline, plain, 1,500 WMB markers, 5 mm, on roll	12 Markers
282-435/011-000 Jumper, insulated, 1-3-5	1
Assembly width incl. end stop	8.5 cm

TOPJOB® S

2004 Series Fuse Plugs on 2002 Series Carrier Terminal Blocks

Fuse plug with pull-tab
for miniature fuses 5 x 20 mm
250 V / I_N 6.3 A
Plug width 6.1 mm / 0.24 in.

Fuse plug with pull-tab
for miniature fuses 5 x 20 mm
250 V / I_N 6.3 A
Plug width 6.1 mm / 0.24 in.

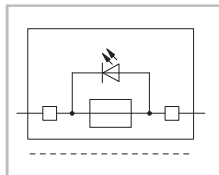
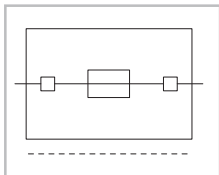

Accessories

WMB Multi marking system,

10 strips with 10 markers per card,
stretchable 5 ... 5.2 mm
plain **793-5501** 5

WMB Multi marking system, plain,

10 strips with 10 markers per card,
stretchable 5 ... 5.2 mm
yellow **793-5501/000-002**
red **793-5501/000-005**
blue **793-5501/000-006**
gray **793-5501/000-007**
orange **793-5501/000-012**
light green **793-5501/000-017**
green **793-5501/000-023**
violet **793-5501/000-024** 5

Item No.	Pack. Unit	Item No.	Pack. Unit
Fuse plug with pull-tab, for miniature fuses 5 x 20 mm Both nominal voltage and current are given by the fuse.		Fuse plug with pull-tab, for miniature fuses 5 x 20 mm, with indicator lamp, gray Both nominal voltage and current are given by the LED or fuse. Leakage current in case of blown fuse: LED 2mA	
● gray	2004-911 50	● 12 ... 30 V	2004-911/1000-541 50
		● 30 ... 65 V	2004-911/1000-542 50
		● 120 V	2004-911/1000-867 50
		● 230 V	2004-911/1000-836 50

Accessories

Appropriate marking systems: WMB/Marking strips

2-conductor carrier terminal block, ① 0.25 ... 2.5 (4) mm ² / AWG 22 ... 12 Terminal block width 5.2 mm / 0.205 in. gray 2002-1661 50	2-conductor carrier terminal block, ④ 0.25 ... 2.5 (4) mm ² / AWG 22 ... 12 Terminal block width 5.2 mm / 0.205 in. gray 2002-1961 50
End and intermediate plate, 1 mm thick orange 2002-1692 100 (4x25) gray 2002-1691 100 (4x25)	End and intermediate plate, 1 mm thick orange 2002-1992 100 (4x25) gray 2002-1991 100 (4x25)
3-conductor carrier terminal block, ② 0.25 ... 2.5 (4) mm ² / AWG 22 ... 12 Terminal block width 5.2 mm / 0.205 in. gray 2002-1761 50	Double-deck carrier terminal block, 0.25 ... 2.5 (4) mm ² / AWG 22 ... 12 Terminal block width 5.2 mm / 0.205 in. L/L 2002-2961 50
End and intermediate plate, 1 mm thick orange 2002-1792 100 (4x25) gray 2002-1791 100 (4x25)	Double-deck carrier terminal block, 0.25 ... 2.5 (4) mm ² / AWG 22 ... 12 Terminal block width 5.2 mm / 0.205 in. L/N 2002-2963 50
4-conductor carrier terminal block, ⑤ 0.25 ... 2.5 (4) mm ² / AWG 22 ... 12 Terminal block width 5.2 mm / 0.205 in. gray 2002-1861 50	End and intermediate plate, 1 mm thick orange 2002-2992 100 (4x25) gray 2002-2991 100 (4x25)
End and intermediate plate, 1 mm thick orange 2002-1892 100 (4x25) gray 2002-1891 100 (4x25)	End plate for fuse terminal blocks, 2 mm thick orange 2002-992 100 (4x25) gray 2002-991 100 (4x25)
	Shorting link, 5 x 20 mm, if the fuse plug is used as disconnect plug I _N 6.3 A 281-503 250 (10x25)

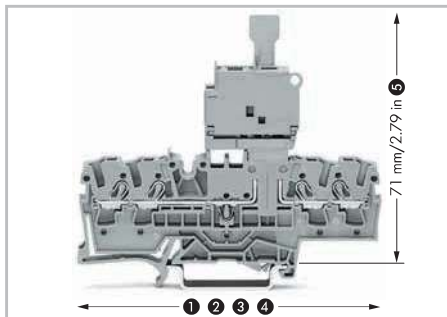

Fuse plug dimensions:

- ① 66.5 mm/2.62 in. for 2002-1661
- ② 76.8 mm/3.02 in. for 2002-1761
- ③ 87.5 mm/3.45 in. for 2002-1861
- ③ 72.9 mm/2.87 in. for 2002-1961
- ④ with inserted fuse plug

Using pluggable fuse holders with rail-mount terminal blocks for control circuit protection is highly advantageous for the user since the function and the wiring are accomplished by two separate parts:

- No additional cost for assembly and wiring
- No risk of accidental contact with live parts during disconnection of fuse plug
- If exchanging a defective fuse, the fuse plug is completely separated from the carrier terminal block. This provides safe fuse changeout away from current carrying parts.
- The fuse plug can be removed by service personnel, avoiding unintentional reclosing of the circuit by another person.
- Quick replacement a fuse by using a prepared "stand-by plug."

The following fuse plug features provide quick and safe handling:

- Optional LED indicates blown fuse
- Marking slot on the fuse plug for clear coordination to the correct carrier terminal block
- Two touch-proof test slots
- High density with only 6.1 mm width of terminal block/ fuse plug
- Instead of a fuse, a shorting link may be used as a disconnect plug.

Miniature fuses 5 x 20

Series Item No.	Overload and short circuit protection		Short circuit protection only	
	Individual argmt.	Group argmt.	Individual argmt.	Group argmt.
Fuse terminal blocks				
2004-911				
2004-911/.....	1.6 W	1.6 W	2.5 W	2.5 W

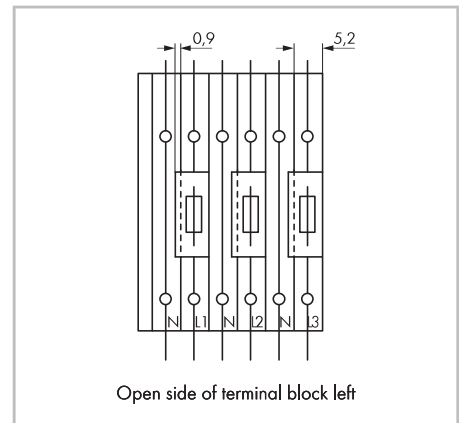

Please note:

The extra width of the plug (6.1 mm compared to 5.2 mm for carrier terminal blocks) must be compensated for by intermediate plates (1 mm) when building an assembly of carrier terminal blocks equipped with fuse plugs.

TOPJOB® S

Fuse Plugs on Carrier Terminal Blocks 6 (10) mm²

2006 Series

Fuse plug with pull-tab 800 V / I _N 10 A Plug width 7.4 mm / 0.291 in.	Fuse plug with pull-tab 800 V / I _N 10 A Plug width 7.4 mm / 0.291 in.	Fuse plug with pull-tab 800 V / I _N 10 A Plug width 10.4 mm / 0.409 in.
--	--	---

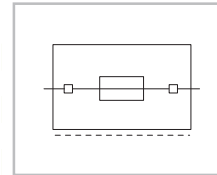
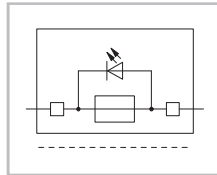
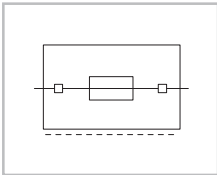

Item No.	Pack. Unit	Item No.	Pack. Unit	Item No.	Pack. Unit
Fuse plug with pull-tab Both nominal voltage and current are given by the fuse. for miniature fuses 5 x 20 mm		Fuse plug with pull-tab, gray, with indicator lamp Both nominal voltage and current are given by the LED or fuse. Leakage current in case of blown fuse: LED 2mA, for miniature fuses 5 x 20 mm		Fuse plug with pull-tab Both nominal voltage and current are given by the fuse. for miniature fuses ¼" x 1¼"	
● gray	2006-911	25	● 12 ... 30 V	2006-911/1000-541	25
			● 30 ... 65 V	2006-911/1000-542	25
			● 120 V	2006-911/1000-867	25
			● 230 V	2006-911/1000-836	25
for miniature fuses 5 x 30 mm		for miniature fuses 5 x 30 mm			
● gray	2006-921	25	● 12 ... 30 V	2006-921/1000-541	25
			● 30 ... 65 V	2006-921/1000-542	25
			● 120 V	2006-921/1000-867	25
			● 230 V	2006-921/1000-836	25
			● 380 ... 500 V	2006-921/1000-859	25
for miniature fuses ¼" x 1¼"		for miniature fuses ¼" x 1¼"			
● gray	2006-931	25	● 12 ... 30 V	2006-931/1000-541	25
			● 30 ... 65 V	2006-931/1000-542	25
			● 120 V	2006-931/1000-867	25
			● 230 V	2006-931/1000-836	25
			● 380 ... 500 V	2006-931/1000-859	25
Item-Specific Accessories		Item-Specific Accessories		Item-Specific Accessories	
End and intermediate plate, 1 mm thick orange 2006-1692 100 (4x25) gray 2006-1691 100 (4x25)		End and intermediate plate, 1 mm thick orange 2006-1692 100 (4x25) gray 2006-1691 100 (4x25)		Intermediate plate, 2.9 mm thick orange 2006-1696 100 (4x25) gray 2006-1695 100 (4x25)	
Accessories fuse plugs					
Appropriate marking systems: WMB/Marking strips					
End plate for fuse terminal blocks, 2 mm thick orange 2006-992 100 (4x25) gray 2006-991 100 (4x25)		Shorting link, 5 x 20 mm, if the fuse plug is used as disconnect plug I _N 6.3 A 281-503 250 (10x25)		Screwless end stop, for DIN 35 rail, 6 mm wide gray 249-116 100 (4x25)	
2-conductor carrier terminal block, 0.5 ... 6 (10) mm ² / AWG 20 ... 8 Terminal block width 7.5 mm / 0.295 in. gray 2006-1661 25		WMB Multi marking system, 10 strips with 10 markers per card, stretchable 5 ... 5.2 mm plain 793-5501 5		Screwless end stop, for DIN 35 rail, 10 mm wide gray 249-117 50 (2x25)	

Approvals see www.wago.com

Fuse plug with pull-tab

800 V / I_N 10 A

Plug width 10.4 mm / 0.409 in.



Using pluggable fuse holders with rail-mounted terminal blocks for control circuit protection is highly advantageous for the user, as the function and the wiring are accomplished by two separate parts:

- No additional cost for assembly and wiring
- No risk of accidental contact with live parts during disconnection of fuse plug
- If exchanging a defective fuse, the fuse plug is completely separated from the carrier terminal block. This provides changeout away from current carrying parts.
- The fuse plug can be removed by service personnel, avoiding unintentional reclosing of the circuit by another person
- Quick replacement a fuse by using a prepared "stand-by plug."

The following features of the fuse plug ensure quick and safe use:

- Optional LED indicates blown fuse
- Markable fuse plug for clear coordination to the correct carrier terminal block
- Two touch-proof test slots
- High density with only 7.5 mm width of terminal block and fuse plug width 7.4 (10.4) mm
- Instead of a fuse, a shorting link may be used as a disconnect plug

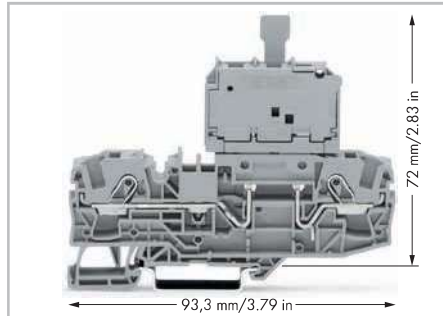
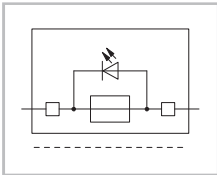

Fuse plug dimensions

Miniature fuses

Series Item No.	Overload and short circuit protection		Short circuit protection only		
	Individual argmt.	Group argmt.	Individual argmt.	Group argmt.	
Fused disconnect terminal blocks					
2006-911	7.5	1.6 W	1.6 W	2.5 W	2.5 W
2006-921	7.5	1.6 W	1.6 W	2.5 W	2.5 W
2006-931	7.5	1.6 W	1.6 W	2.5 W	2.5 W
2006-931 /099...	10.4	2.5 W	2.5 W	2.5 W	2.5 W
2006-931 /1099...	10.4	2.5 W	2.5 W	2.5 W	2.5 W

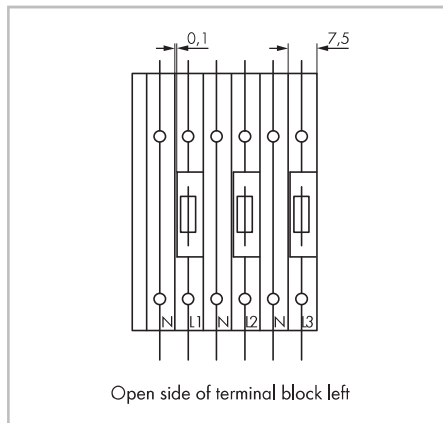

Item No.	Pack. Unit
Fuse plug with pull-tab, gray, with indicator lamp	
Both nominal voltage and current are given by the LED or fuse. Leakage current in case of blown fuse: LED 2mA, for miniature fuses ¼" x 1¼"	
○ 12 ... 30 V	2006-931/1099-541 25
○ 30 ... 65 V	2006-931/1099-542 25
○ 120 V	2006-931/1099-867 25
○ 230 V	2006-931/1099-836 25
○ 380 ... 500 V	2006-931/1099-859 25



Open side of terminal block left

Item-Specific Accessories

Intermediate plate, 2.9 mm thick

 orange	2006-1696	100 (4x25)
 gray	2006-1695	100 (4x25)

When using the 10.4 mm wide plug,

please note:

The extra width of the plug (10.4 mm compared to 7.5 mm for carrier terminal blocks) must be compensated for by intermediate plates (2.9 mm) when building an assembly of carrier terminal blocks equipped with fuse plugs.

TOPJOB® S

Diode Terminal Blocks and LED Terminal Blocks 1.5 (2.5) mm²

2001 Series

<p>0.25 ... 1.5 (2.5) mm² ① AWG 22 ... 14 U_N 250 V, U_{RM} 1000 V 1N4007 - 0.5 A continuous current Terminal block width 4.2 mm / 0.165 in. 9 ... 11 mm / 0.39 in. ②</p>	<p>0.25 ... 1.5 (2.5) mm² ① AWG 22 ... 14 U_N 250 V, U_{RM} 1000 V 1N4007 - 0.5 A continuous current Terminal block width 4.2 mm / 0.165 in. 9 ... 11 mm / 0.39 in. ②</p>	<p>0.25 ... 1.5 (2.5) mm² ① AWG 22 ... 14 24 VDC I_F 0.025 A max. Terminal block width 4.2 mm / 0.165 in. 9 ... 11 mm / 0.39 in. ②</p>
--	--	---

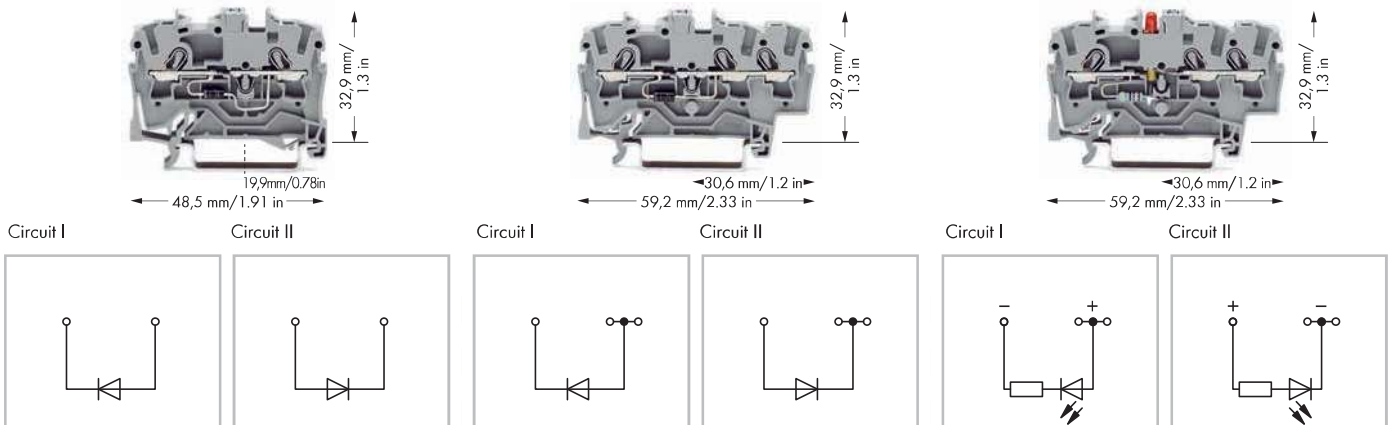

Item No.	Pack. Unit	Item No.	Pack. Unit	Item No.	Pack. Unit
2-conductor diode terminal block with 1N4007 diode, gray		3-conductor diode terminal block with 1N4007 diode, gray		3-conductor LED terminal block with red LED, 24 VDC, gray	
Notice: This LED terminal block cannot be commoned with push-in type jumper bars!					
○ Circuit I	2001-1211/1000-411	100	○ Circuit I	2001-1311/1000-411	100
○ Circuit II	2001-1211/1000-410	100	○ Circuit II	2001-1311/1000-410	100
				○ Circuit I	2001-1321/1000-413
				○ Circuit II	2001-1321/1000-434

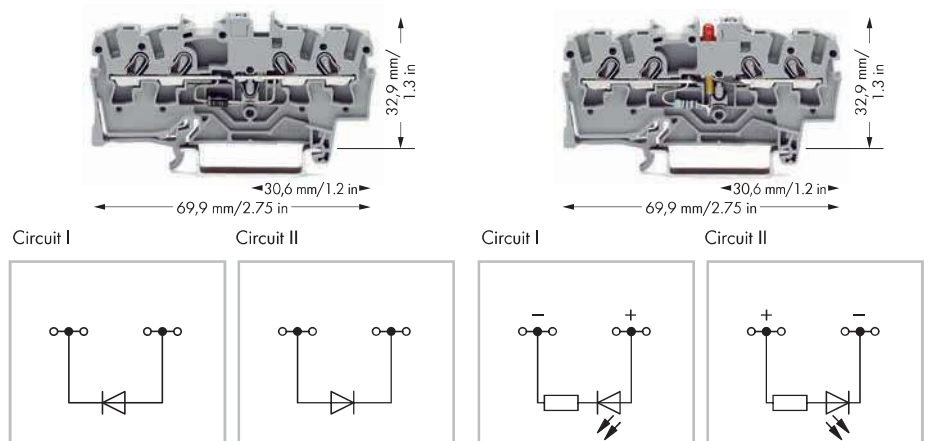

	Item No.	Pack. Unit	Item No.	Pack. Unit
Through terminal blocks with same profile, see page 20	4-conductor diode terminal block with 1N4007 diode, gray		4-conductor LED terminal block with red LED, 24 VDC, gray	
	Notice: This LED terminal block cannot be commoned with push-in type jumper bars!			
	○ Circuit I	2001-1411/1000-411	100	○ Circuit I
	○ Circuit II	2001-1411/1000-410	100	○ Circuit II
				○ Circuit I
				○ Circuit II

Circuit Configuration Examples

Diode Terminal Blocks and LED Terminal Blocks

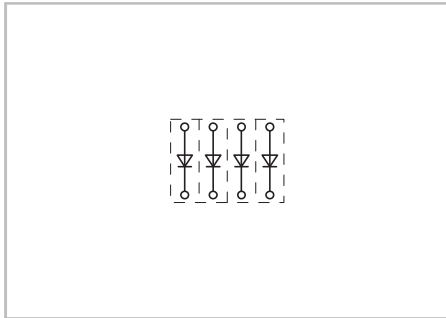

Open diode gates can be created using the following terminal blocks:
2001-1211/1000-410 or
2001-1211/1000-411



These diode terminal blocks have been specially developed for custom diode circuits, such as lamp test and collective fault signal circuits. Using LED terminal blocks, monitoring units can be designed, e.g., for control and operating circuits.

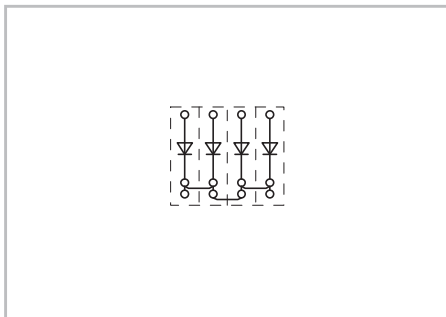

Polarized diode gates with common cathode can be created using the following terminal blocks:
2001-1311/1000-410 or
2001-1311/1000-411

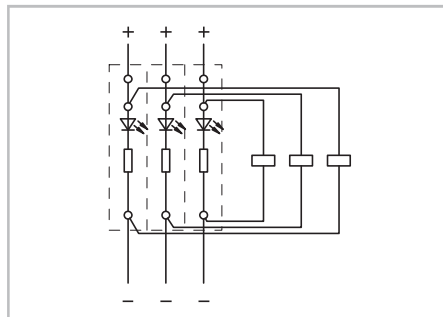

Circuit-related voltage indications can be created using the following terminal blocks:
2001-1321/1000-434 or
2001-1321/1000-413

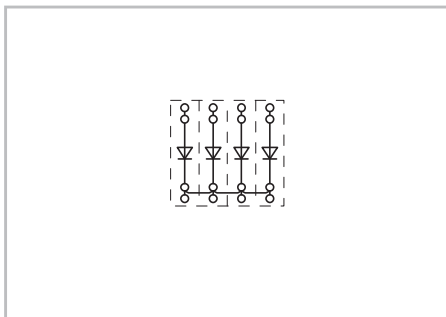

Polarized diode gates with common cathode can be created using the following terminal blocks:
2001-1411/1000-410 or
2001-1411/1000-411

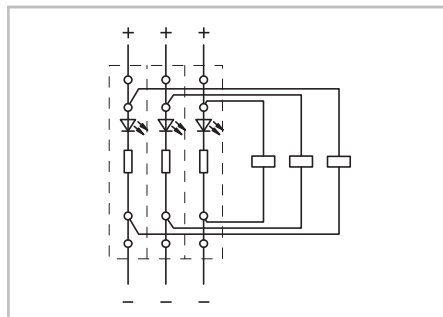

Circuit-related voltage indications can be created using the following terminal blocks:
2001-1421/1000-434 or
2001-1421/1000-413

- ① Conductor sizes: 0.25 mm² ... 2.5 mm² "s + f-st";
Push-in conductor sizes: 0.5 mm² ... 2.5 mm² "s"
and 0.75 mm² ... 1.5 mm²
"insulated ferrules, 12 mm"
- ② Strip length, see packaging or instructions.

2001 Series Accessories

Insulation stop,

5 pcs/strip, 0.25 ... 0.5 mm ² light gray	2001-171	200 (8x25)
--	-----------------	------------

Push-in type jumper bar, insulated,

I_N 18 A, light gray		
2-way	2001-402	200 (8x25)
3-way	2001-403	200 (8x25)
4-way	2001-404	200 (8x25)
5-way	2001-405	100 (4x25)
6-way	2001-406	100 (4x25)
7-way	2001-407	100 (4x25)
8-way	2001-408	100 (4x25)
9-way	2001-409	100 (4x25)
10-way	2001-410	100 (4x25)



Push-in type jumper bar, insulated,

I_N 18 A, light gray		
from 1 to 3	2001-433	200 (8x25)
from 1 to 4	2001-434	200 (8x25)
from 1 to 5	2001-435	100 (4x25)
from 1 to 6	2001-436	100 (4x25)
from 1 to 7	2001-437	100 (4x25)
from 1 to 8	2001-438	100 (4x25)
from 1 to 9	2001-439	100 (4x25)
from 1 to 10	2001-440	100 (4x25)

TOPJOB® S

Diode Terminal Blocks and LED Terminal Blocks 2.5 (4) mm²

2002 Series

<p>0.25 ... 2.5 (4) mm² ① AWG 22 ... 12 U_N 250 V, U_{RM} 1000 V 1N4007 - 0.5 A continuous current Terminal block width 5.2 mm / 0.205 in.  10 ... 12 mm / 0.43 in. ②</p>	<p>0.25 ... 2.5 (4) mm² ① AWG 22 ... 12 U_N 250 V, U_{RM} 1000 V 1N4007 - 0.5 A continuous current Terminal block width 5.2 mm / 0.205 in.  10 ... 12 mm / 0.43 in. ②</p>	<p>0.25 ... 2.5 (4) mm² ① AWG 22 ... 12 24 VDC I_F 0.025 A max. Terminal block width 5.2 mm / 0.205 in.  10 ... 12 mm / 0.43 in. ②</p>
--	---	--

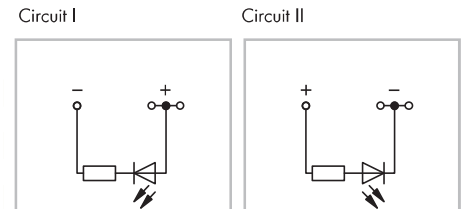
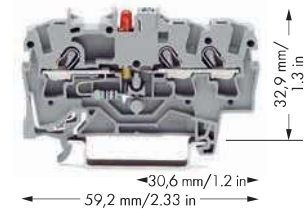
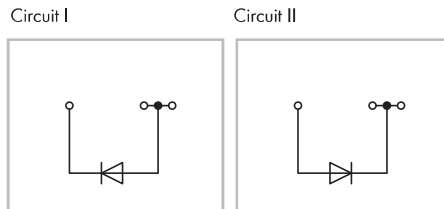
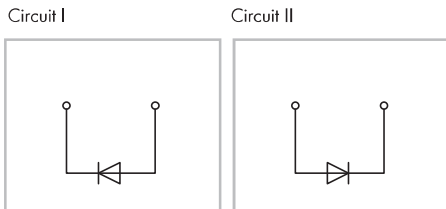
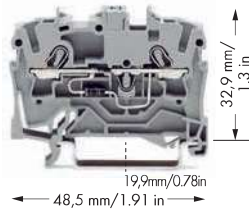

Item No.	Pack. Unit	Item No.	Pack. Unit	Item No.	Pack. Unit
2-conductor diode terminal block with 1N4007 diode, gray		3-conductor diode terminal block with 1N4007 diode, gray		3-conductor LED terminal block with red LED, 24 VDC, gray Notice: This LED terminal block cannot be commoned with push-in type jumper bars!	
○ Circuit I	2002-1211/1000-411 100	○ Circuit I	2002-1311/1000-411 100	○ Circuit I	2002-1321/1000-413 100
○ Circuit II	2002-1211/1000-410 100	○ Circuit II	2002-1311/1000-410 100	○ Circuit II	2002-1321/1000-434 100

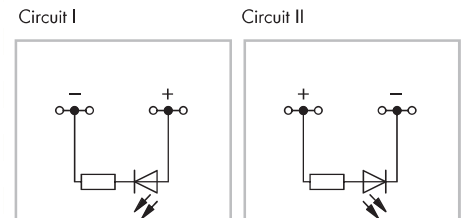
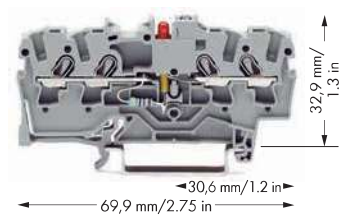
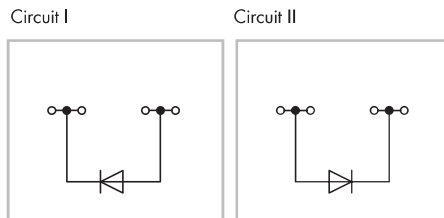
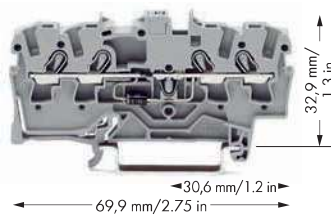

	Item No.	Pack. Unit	Item No.	Pack. Unit
Through terminal blocks with same profile, see page 22	4-conductor diode terminal block with 1N4007 diode, gray		4-conductor LED terminal block with red LED, 24 VDC, gray Notice: This LED terminal block cannot be commoned with push-in type jumper bars!	
	○ Circuit I	2002-1411/1000-411 100	○ Circuit I	2002-1421/1000-413 100
	○ Circuit II	2002-1411/1000-410 100	○ Circuit II	2002-1421/1000-434 100

Circuit Configuration Examples

Diode Terminal Blocks and LED Terminal Blocks

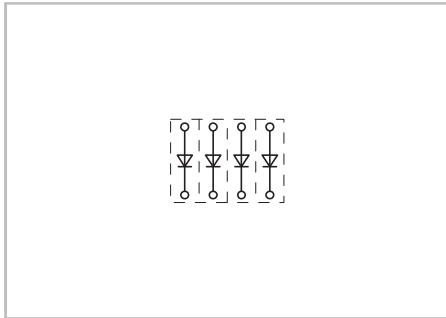

Open diode gates can be created using the following terminal blocks:
2002-1211/1000-410 or 2002-1211/1000-411



These diode terminal blocks have been specially developed for custom diode circuits, such as lamp test and collective fault signal circuits.

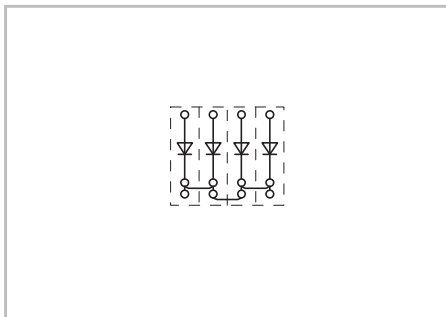

Polarized diode gates with common cathode can be created using the following terminal blocks:
2002-1311/1000-410 or 2002-1311/1000-411

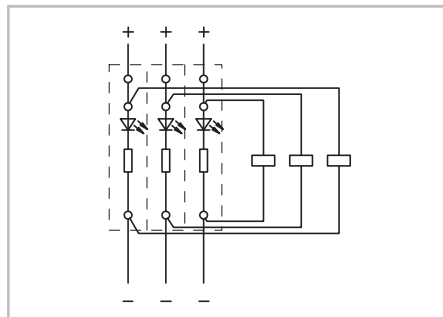

Circuit-related voltage indications can be created using the following terminal blocks:
2002-1321/1000-434 or 2002-1321/1000-413

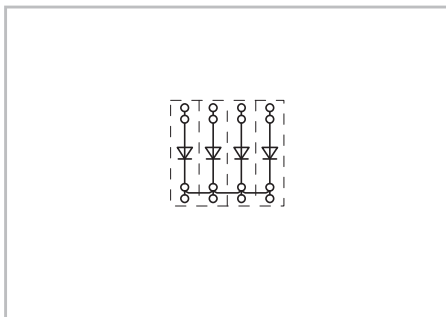

Polarized diode gates with common cathode can be created using the following terminal blocks:
2002-1411/1000-410 or 2002-1411/1000-411

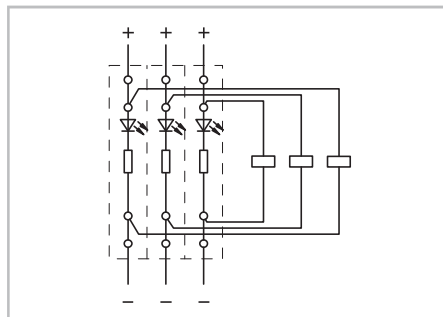

Circuit-related voltage indications can be created using the following terminal blocks:
2002-1421/1000-434 or 2002-1421/1000-413

- ① Conductor sizes: 0.25 mm² ... 4 mm² "s + fst";
 Push-in conductor sizes: 0.75 mm² ... 4 mm² "s"
 and 0.75 mm² ... 2.5 mm²
 "insulated ferrules, 12 mm"
- ② Strip length, see packaging or instructions.

2002 Series Accessories

Insulation stop,			
	5 pcs/strip, 0.25 ... 0.5 mm ²	light gray	2002-171 200 (8x25)

Insulation stop,			
	5 pcs/strip, 0.75 ... 1 mm ²	dark gray	2002-172 200 (8x25)

Push-in type jumper bar, insulated,			
	I _N 25 A, light gray		
	2-way	2002-402	200 (8x25)
	3-way	2002-403	200 (8x25)
	4-way	2002-404	200 (8x25)
	5-way	2002-405	100 (4x25)
	6-way	2002-406	100 (4x25)
	7-way	2002-407	100 (4x25)
	8-way	2002-408	100 (4x25)
	9-way	2002-409	100 (4x25)
	10-way	2002-410	100 (4x25)

Push-in type jumper bar, insulated,			
	I _N 25 A, light gray		
	from 1 to 3	2002-433	200 (8x25)
	from 1 to 4	2002-434	200 (8x25)
	from 1 to 5	2002-435	100 (4x25)
	from 1 to 6	2002-436	100 (4x25)
	from 1 to 7	2002-437	100 (4x25)
	from 1 to 8	2002-438	100 (4x25)
	from 1 to 9	2002-439	100 (4x25)
	from 1 to 10	2002-440	100 (4x25)

TOPJOB® S

Diode Terminal Blocks 4 (6) mm²

2004 Series

0.5 ... 4 (6) mm ² ① AWG 20 ... 10 U _N 250 V, U _{RM} 1000 V 1N5408 - 1.5 A continuous current Terminal block width 6.2 mm / 0.244 in. □ 11 ... 13 mm / 0.47 in. ②	0.5 ... 4 (6) mm ² ① AWG 20 ... 10 U _N 250 V, U _{RM} 1000 V 1N5408 - 1.5 A continuous current Terminal block width 6.2 mm / 0.244 in. □ 11 ... 13 mm / 0.47 in. ②
--	--

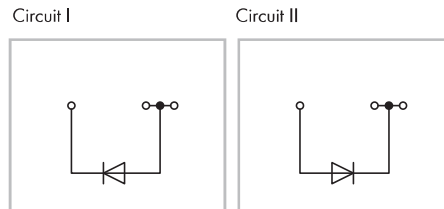
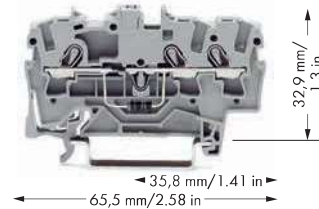
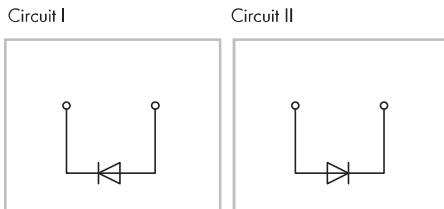
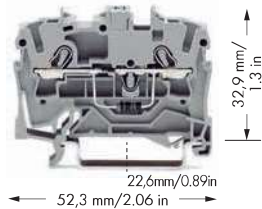

Item No.	Pack. Unit	Item No.	Pack. Unit
2-conductor diode terminal block with 1N5408 diode, gray		3-conductor diode terminal block with 1N5408 diode, gray	
○ Circuit I 2004-1211/1000-401	50	○ Circuit I 2004-1311/1000-401	50
○ Circuit II 2004-1211/1000-400	50	○ Circuit II 2004-1311/1000-400	50

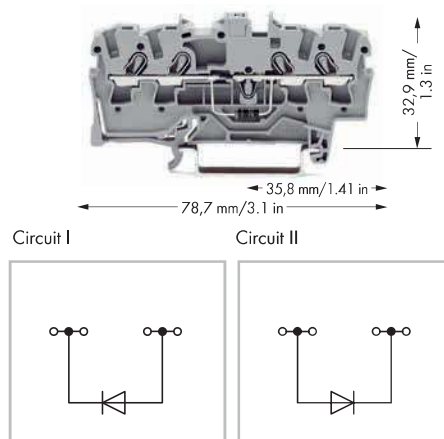

Item No.	Pack. Unit
Through terminal blocks with same profile, see page 18	
4-conductor diode terminal block with 1N5408 diode, gray	
○ Circuit I 2004-1411/1000-401	50
○ Circuit II 2004-1411/1000-400	50

Circuit Configuration Examples

Diode Terminal Blocks

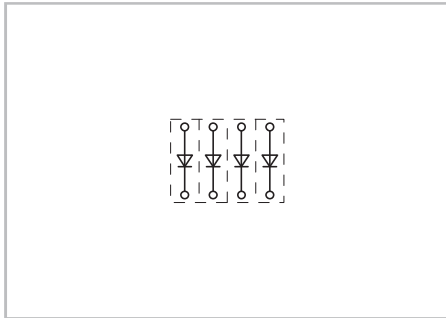

Open diode gates can be created using the following terminal blocks:
2004-1211/1000-400 or
2004-1211/1000-401



These diode terminal blocks have been specially developed for custom diode circuits, such as lamp test and collective fault signal circuits.

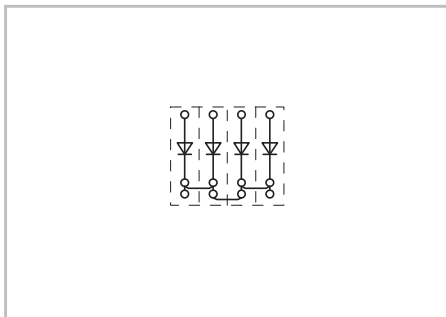



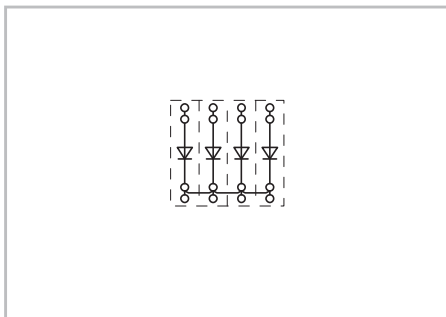



Polarized diode gates with common cathode can be created using the following terminal blocks:
2004-1311/1000-400 or
2004-1311/1000-401



Polarized diode gates with common cathode can be created using the following terminal blocks:
2004-1411/1000-400 or
2004-1411/1000-401

- ① Conductor sizes: 0.5 mm² ... 6 mm² "s + f-st";
Push-in conductor sizes: 1 mm² ... 6 mm² "s"
and 0.75 mm² ... 2.5 mm²
"insulated ferrule, 1.2 mm"
- ② Strip length, see packaging or instructions.



2004 Series Accessories

Insulation stop,			
	5 pcs/strip, 0.25 ... 0.5 mm ² light gray	2004-171	200 (8x25)
Insulation stop,			
	5 pcs/strip, 0.75 ... 1 mm ² dark gray	2004-172	200 (8x25)
Push-in type jumper bar, insulated,			
	I _N 32 A, light gray		
	2-way	2004-402	200 (8x25)
	3-way	2004-403	200 (8x25)
	4-way	2004-404	100 (4x25)
	5-way	2004-405	100 (4x25)
	6-way	2004-406	100 (4x25)
	7-way	2004-407	100 (4x25)
	8-way	2004-408	100 (4x25)
	9-way	2004-409	100 (4x25)
	10-way	2004-410	100 (4x25)
Push-in type jumper bar, insulated,			
	I _N 32 A, light gray		
	from 1 to 3	2004-433	200 (8x25)
	from 1 to 4	2004-434	200 (8x25)
	from 1 to 5	2004-435	100 (4x25)
	from 1 to 6	2004-436	100 (4x25)
	from 1 to 7	2004-437	100 (4x25)
	from 1 to 8	2004-438	100 (4x25)
	from 1 to 9	2004-439	100 (4x25)
	from 1 to 10	2004-440	100 (4x25)
Wire commoning chain, 50 connections,			
	insulated, I _N 8 A		
	black	210-103	1
Wire commoning chain, 50 connections,			
	insulated, I _N 8 A		
	blue	210-123	1

TOPJOB® S

Double-Deck Diode Terminal Blocks and LED Terminal Blocks 2.5 (4) mm²

2002 Series

0.25 ... 2.5 (4) mm ² ① AWG 22 ... 12 U _N 250 V, U _{RM} 1000 V 1N4007 - 0.5 A continuous current Terminal block width 5.2 mm / 0.205 in.  10 ... 12 mm / 0.43 in.②	0.25 ... 2.5 (4) mm ² ① AWG 22 ... 12 U _N 250 V, U _{RM} 1000 V 1N4007 - 0.5 A continuous current Terminal block width 5.2 mm / 0.205 in.  10 ... 12 mm / 0.43 in.②	0.25 ... 2.5 (4) mm ² ① AWG 22 ... 12 24 VDC I _F 0.025 A max. Terminal block width 5.2 mm / 0.205 in.  10 ... 12 mm / 0.43 in.②
---	--	--

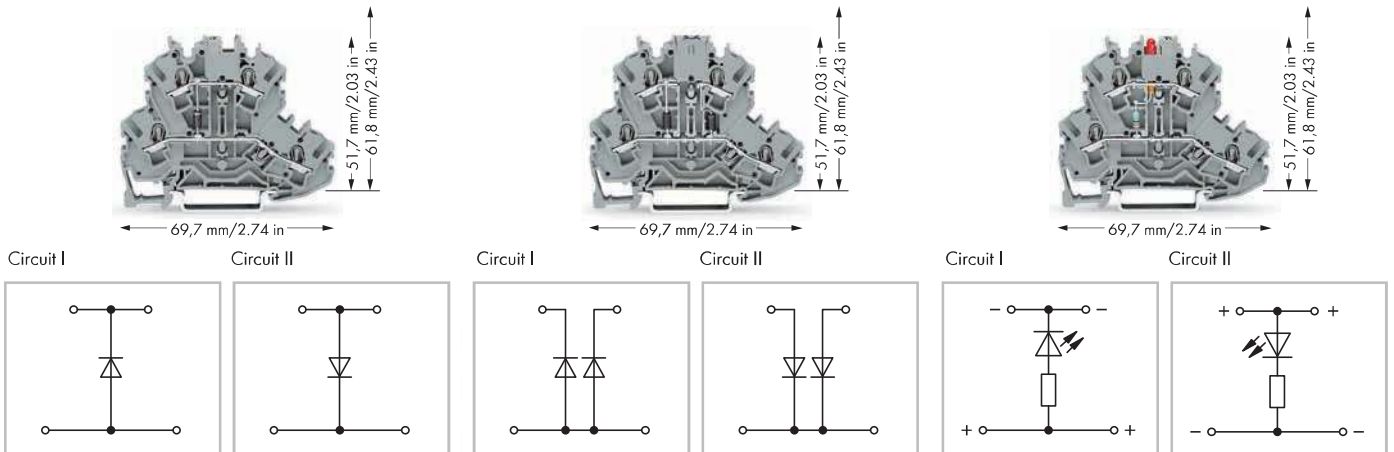

Item No.	Pack. Unit	Item No.	Pack. Unit	Item No.	Pack. Unit
Double-deck diode terminal block with 1N4007 diode, gray		Double-deck diode terminal block with 2 diodes 1N4007, gray		Double-deck LED terminal block with red LED, 24 VDC, gray	
● Circuit I	2002-2211/1000-410 50	● Circuit I	2002-2213/1000-487 50	● Circuit I	2002-2221/1000-434 50
● Circuit II	2002-2211/1000-411 50	● Circuit II	2002-2213/1000-488 50	● Circuit II	2002-2221/1000-413 50

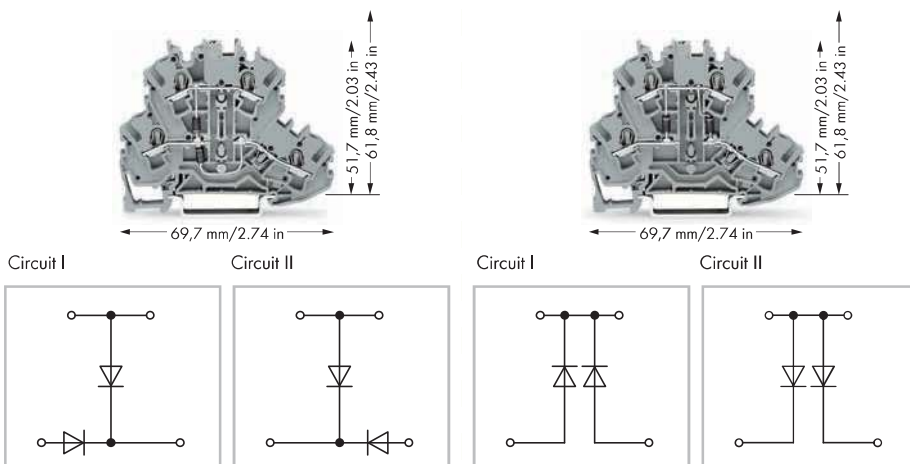

Item No.	Pack. Unit	Item No.	Pack. Unit	Item No.	Pack. Unit
Double-deck diode terminal block with 2 diodes 1N4007, gray		Double-deck diode terminal block with 2 diodes 1N4007, gray		Through terminal blocks with same profile, see page 36	
● Circuit I	2002-2214/1000-492 50	● Circuit I	2002-2214/1000-489 50		
● Circuit II	2002-2214/1000-491 50	● Circuit II	2002-2214/1000-490 50		

Circuit Configuration Examples

Double-Deck Diode and LED Terminal Blocks

PUSH-IN CAGE CLAMP®

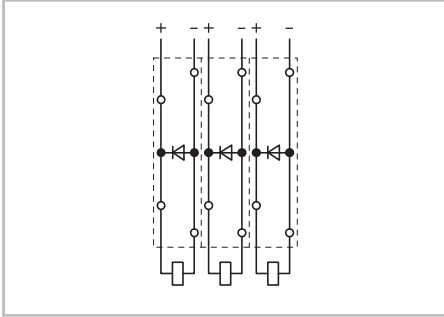

Recovery diodes can be created using the following terminal blocks:
2002-2211/1000-410 or
2002-2211/1000-411

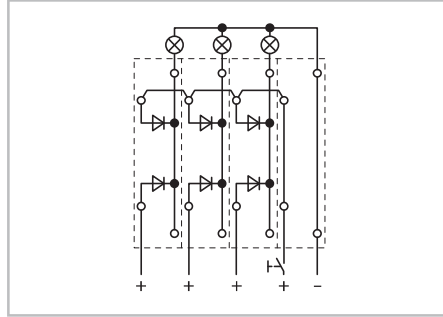

Lamp test circuits can be created using the following terminal blocks:
2002-2213/1000-487 or
2002-2213/1000-488

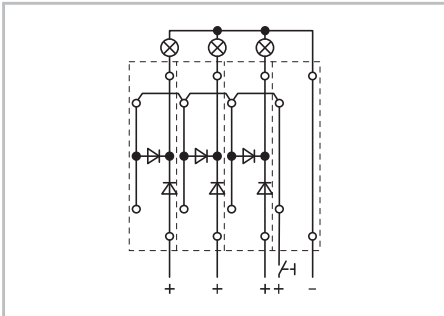

Lamp test circuits can be created using the following terminal blocks:
2002-2214/1000-492 or
2002-2214/1000-491

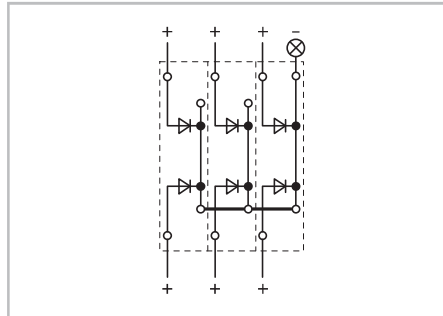

Collective fault signals can be created using the following terminal blocks:
2002-2214/1000-489 or
2002-2214/1000-490

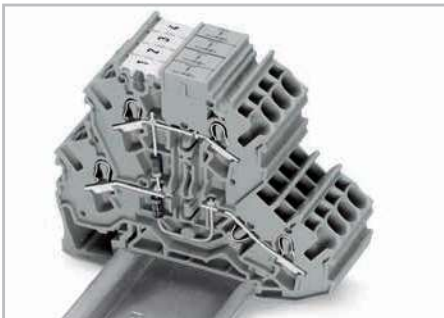

Double-deck diode terminal blocks have been specially developed for custom diode circuits, such as lamp test and collective fault signal circuits. Using LED terminal blocks, monitoring units can be designed, e.g., for control and operating circuits. The terminal blocks provide high-density wiring, while maintaining a width of only 5.2 mm. Push-in type jumper bars provide additional options for custom circuit design.

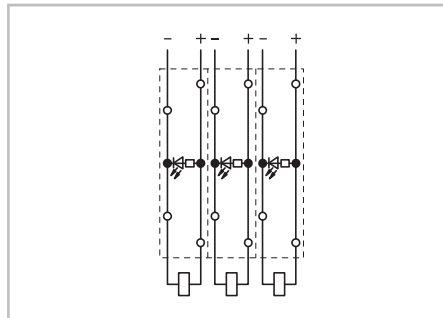



Circuit-related voltage indications can be created using the following terminal blocks:
2002-2221/1000-434 or
2002-2221/1000-413

- ① Conductor sizes: 0.25 mm² ... 4 mm² "s + fst";
Push-in conductor sizes: 0.75 mm² ... 4 mm² "s"
and 0.75 mm² ... 2.5 mm²
"insulated ferrules, 12 mm"
- ② Strip length, see packaging or instructions.

2002 Series Accessories

End and intermediate plate, 0.8 mm thick			
	orange	2002-2292	100 (4x25)
	gray	2002-2291	100 (4x25)

Double-deck marker carrier,			
	pivoting		
	gray	2002-121	50 (2x25)

Insulation stop,			
	5 pcs/strip,		
	0.25 ... 0.5 mm ²		
	light gray	2002-171	200 (8x25)

Insulation stop,			
	5 pcs/strip,		
	0.75 ... 1 mm ²		
	dark gray	2002-172	200 (8x25)



Push-in type jumper bar, insulated,			
	I _N 25 A,		
	light gray		
	2-way	2002-402	200 (8x25)
	3-way	2002-403	200 (8x25)
	4-way	2002-404	200 (8x25)
	5-way	2002-405	100 (4x25)
	6-way	2002-406	100 (4x25)
	7-way	2002-407	100 (4x25)
	8-way	2002-408	100 (4x25)
	9-way	2002-409	100 (4x25)
10-way	2002-410	100 (4x25)	

Push-in type jumper bar, insulated,			
	I _N 25 A,		
	light gray		
	from 1 to 3	2002-433	200 (8x25)
	from 1 to 4	2002-434	200 (8x25)
	from 1 to 5	2002-435	100 (4x25)
	from 1 to 6	2002-436	100 (4x25)
	from 1 to 7	2002-437	100 (4x25)
	from 1 to 8	2002-438	100 (4x25)
	from 1 to 9	2002-439	100 (4x25)
	from 1 to 10	2002-440	100 (4x25)

TOPJOB® S

Triple-Deck Diode Terminal Blocks and LED Terminal Blocks 2.5 (4) mm²

2002 Series

<p>0.25 ... 2.5 (4) mm² ① AWG 22 ... 12 U_N 250 V, U_{RM} 1000 V 1N4007 - 0.5 A continuous current Terminal block width 5.2 mm / 0.205 in.  10 ... 12 mm / 0.43 in. ②</p>	<p>0.25 ... 2.5 (4) mm² ① AWG 22 ... 12 U_N 250 V, U_{RM} 1000 V 1N4007 - 0.5 A continuous current Terminal block width 5.2 mm / 0.205 in.  10 ... 12 mm / 0.43 in. ②</p>	<p>0.25 ... 2.5 (4) mm² ① AWG 22 ... 12 24 VDC I_F 0.025 A max. Terminal block width 5.2 mm / 0.205 in.  10 ... 12 mm / 0.43 in. ②</p>
--	---	--

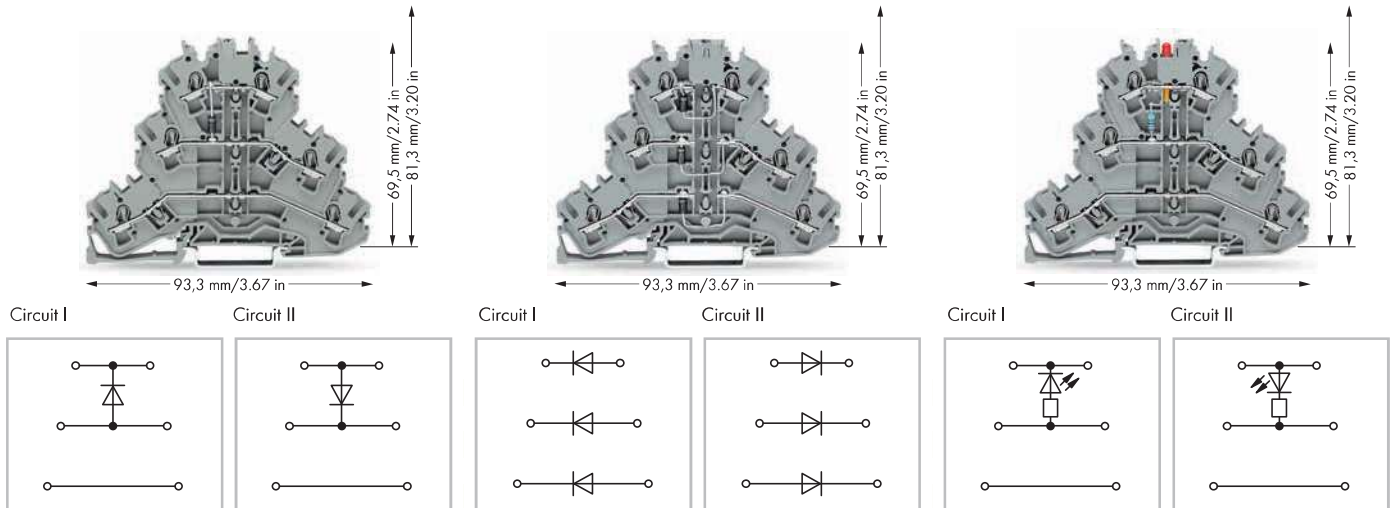

Item No.	Pack. Unit	Item No.	Pack. Unit	Item No.	Pack. Unit
Triple-deck diode terminal block with 1N4007 diode, gray		Triple-deck diode terminal block with 3 diodes 1N4007, gray		Triple-deck LED terminal block with red LED, 24 VDC, gray	
● Circuit I	2002-3211/1000-410 50	● Circuit I	2002-3212/1000-673 50	● Circuit I	2002-3221/1000-434 50
● Circuit II	2002-3211/1000-411 50	● Circuit II	2002-3212/1000-674 50	● Circuit II	2002-3221/1000-413 50

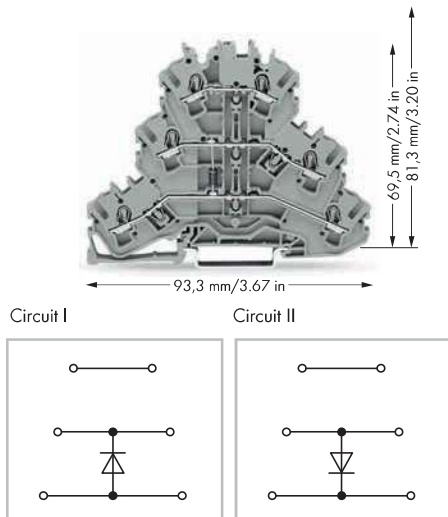

Item No.	Pack. Unit		
Triple-deck diode terminal block with 1N4007 diode, gray		Through terminal blocks with same profile, see page 46	
● Circuit I	2002-3211/1000-675 50		
● Circuit II	2002-3211/1000-676 50		

Circuit Configuration Example

Triple-Deck Diode Terminal Blocks

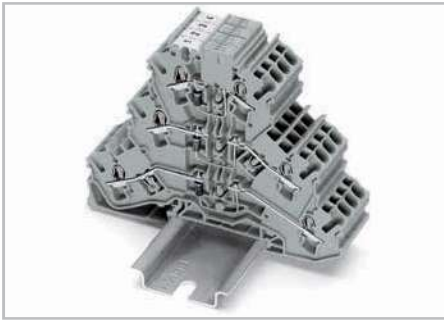

Triple-deck diode terminal blocks have been specially developed for custom diode circuits, such as lamp test and collective fault signal circuits. Using LED terminal blocks, monitoring units can be designed, e.g., for control and operating circuits. The terminal blocks provide high-density wiring, while maintaining a width of only 5.2 mm. Push-in type jumper bars provide additional options for custom circuit design.

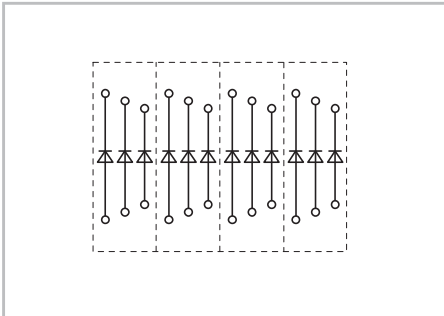

Open diode gates can be created, which can be connected individually using the following terminal blocks:
2002-3212/1000-673 or 2002-3212/1000-674
 Using push-in type jumper bars, individual levels can be turned into polarized diode gates.





















Double-deck and triple-deck LED terminal blocks

- ① Conductor sizes: 0.25 mm² ... 4 mm² "s + fst"; Push-in conductor sizes: 0.75 mm² ... 4 mm² "s" and 0.75 mm² ... 2.5 mm² "insulated ferrules, 12 mm"
- ② Strip length, see packaging or instructions.

2002 Series Accessories

Appropriate marking systems: WMB/WMB Inline/Marking strips

End and intermediate plate, 0.8 mm thick  <ul style="list-style-type: none"> orange 2002-3292 100 (4x25) gray 2002-3291 100 (4x25) 	End plate,  <ul style="list-style-type: none"> for modular TOPJOB® S connectors, 1.5 mm thick gray 2002-541 100 (4x25)
Triple-deck marker carrier,  <ul style="list-style-type: none"> pivoting gray 2002-131 50 (2x25) 	Test plug,  <ul style="list-style-type: none"> with 500 mm cable, 2 mm Ø red 210-136 50
Insulation stop,  <ul style="list-style-type: none"> 5 pcs/strip, 0.25 ... 0.5 mm² light gray 2002-171 200 (8x25) 	Test plug adapter,  <ul style="list-style-type: none"> for 4 mm Ø test plug gray 2009-174 100 (4x25)
Insulation stop,  <ul style="list-style-type: none"> 5 pcs/strip, 0.75 ... 1 mm² dark gray 2002-172 200 (8x25) 	Testing tap,  <ul style="list-style-type: none"> for max. 2.5 mm² gray 2009-182 100 (4x25)
Push-in type jumper bar, insulated,  <ul style="list-style-type: none"> I_N 25 A, light gray 2-way 2002-402 200 (8x25) 3-way 2002-403 200 (8x25) 4-way 2002-404 200 (8x25) 5-way 2002-405 100 (4x25) 6-way 2002-406 100 (4x25) 7-way 2002-407 100 (4x25) 8-way 2002-408 100 (4x25) 9-way 2002-409 100 (4x25) 10-way 2002-410 100 (4x25) 	Banana plug,  <ul style="list-style-type: none"> for socket 4 mm Ø, color mixed 215-111 50
	WMB Multi marking system,  <ul style="list-style-type: none"> 10 strips with 10 markers per card, stretchable 5 ... 5.2 mm plain 793-5501 5
	WMB Inline, plain,  <ul style="list-style-type: none"> stretchable 5 ... 5.2 mm, 1,500 WMB markers, 5 mm, on roll white 2009-115 1
Push-in type jumper bar, insulated,  <ul style="list-style-type: none"> I_N 25 A, light gray from 1 to 3 2002-433 200 (8x25) from 1 to 4 2002-434 200 (8x25) from 1 to 5 2002-435 100 (4x25) from 1 to 6 2002-436 100 (4x25) from 1 to 7 2002-437 100 (4x25) from 1 to 8 2002-438 100 (4x25) from 1 to 9 2002-439 100 (4x25) from 1 to 10 2002-440 100 (4x25) 	Marking strip, plain,  <ul style="list-style-type: none"> 11 mm wide, 50 m roll white 2009-110 1
	TOPJOB® S group marker carrier,  <ul style="list-style-type: none"> snap-on type for jumper slot, 5 mm wide gray 2009-191 50 (2x25)
	Screwless end stop,  <ul style="list-style-type: none"> for DIN 35 rail, 6 mm wide gray 249-116 100 (4x25)
Modular TOPJOB® S connector,  <ul style="list-style-type: none"> can be snapped together, for jumper contact slot gray 2002-511 100 (4x25) 	Screwless end stop,  <ul style="list-style-type: none"> for DIN 35 rail, 10 mm wide gray 249-117 50 (2x25)
Spacer module, can be snapped together,  <ul style="list-style-type: none"> e.g., for bridging commoned terminal blocks gray 2002-549 100 (4x25) 	