

Catalogue

May

05

**Altivar 78**  
**Flux Vector Control**  
**AC Variable Speed Drives**



3-phase variable speed drive  
2 HP to 1500 HP (2.2 kW to 800 kW), 525 to 690 VAC



# Variable speed drives for asynchronous motors

Altivar 78

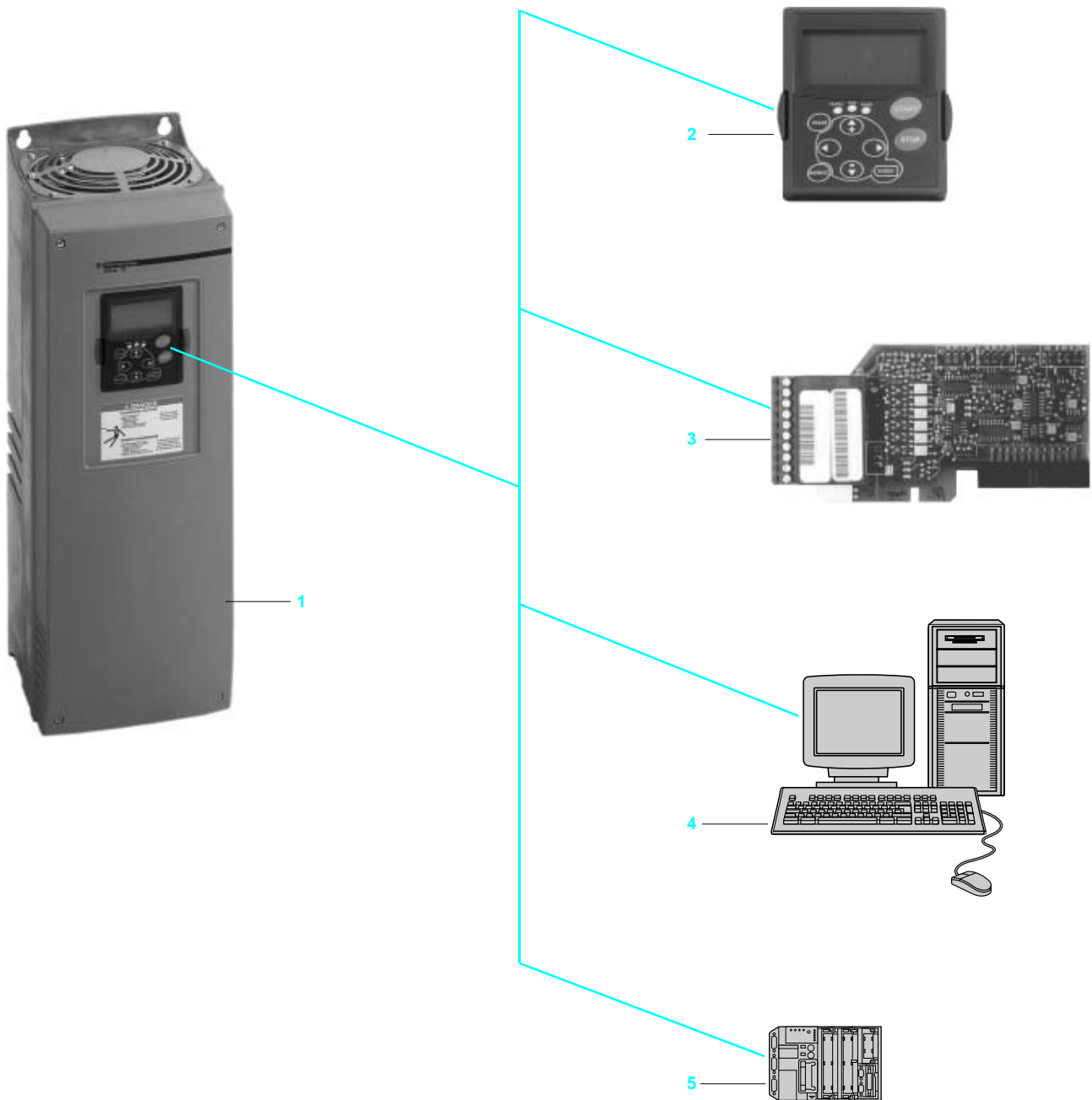

# Variable speed drives for asynchronous motors

## Altivar 78

### Applications

A compact and robust variable speed drive for 3-phase asynchronous motors, the Altivar 78 1 incorporates the latest technological developments and its innovative functions meet the requirements of the most common applications, notably:

- ventilation,
- air-conditioning,
- pumping,
- conveying,
- grinding,
- handling and lifting.

The Altivar 78 has several application-specific preset configurations with a few basic parameters, which can be modified using the programming terminal 2 to create additional functions.

The Altivar 78 range extends across a range of motor power ratings from 2,2 to 710 kW (2 to 800 HP) for high torque applications and from 3 to 800 kW (3 to 800 HP) for standard torque applications with one single type of power supply from 525 to 690 V.

Despite its high performance, it is easy to adjust. The introduction of elements on the motor rating plate and autotuning make it possible to obtain high torque together with remarkable drive quality, even at very low rotation speeds (< 0.5 Hz).

For applications which require exceptional speed precision even at very low speed, and full torque at zero speed, a closed loop flux vector variable speed drive can be supplied.

### Functions

The main functions are:

- integrated PID drive (flow rate, pressure, speed correction),
- 9 possible preset speeds,
- JOG operation,
- brake release sequences for translational movement and hoisting,
- user-definable analogue and logic inputs,
- ± speed,
- skip frequencies,
- local/remote control function,
- logic functions,
- starting and speed regulation via flux vector control,
- multi-pump and fan control function,
- protection of motor and variable speed drive,
- automatic catching of spinning load with speed search (catch on the fly),
- high overtorque on start-up,
- separate 24 V  $\overline{\text{---}}$  supply is possible for control circuit,
- integrated line choke for protection against supply overvoltage and reduction of harmonic distortion.

### Programming terminal

The Altivar 78 is supplied with a programming terminal which:

- controls the variable speed drive in local mode,
- configures the various parameters,
- provides a remote display and indication of the variable speed drive status,
- copies and backs up the parameters.

### Options

Possible options, according to the rating:

- additional I/O card 3, 11 available (see page 60628/2),
- PC-based setup software 4 (see page 60628/2),
- various dialogue and communication options 5 can be used with the drives (Modbus, Profibus DP, LonWorks, CANopen (slave), N2, DeviceNet communication cards) (see page 60628/3),
- braking resistors (see page 60626/3),
- dv/dt filters when motor cables are 30 meter long maximum (see page 60625/2),
- remote mounting kit for programming terminal which enables installation of the terminal on the door of the enclosure or operator panel (see page 60629/2),
- enclosure kit for converting to IP 54 (NEMA Type 12) enclosure (see page 60629/2).

# Variable speed drives for asynchronous motors

## Altivar 78

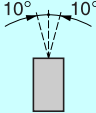
Environment characteristics																																																										
<b>Conforming to standards</b>		Altivar 78 drives have been developed to conform to the strictest national and international standards and the recommendations relating to electrical industrial control devices (IEC, EN, NFC, VDE), in particular: <ul style="list-style-type: none"> <li>- low voltage: EN 50178,</li> <li>- electrical isolation: conforming to EN 50178, PELV,</li> <li>- EMC immunity: conforming to IEC 61800-3, EN 50082-1, -2,</li> <li>- EMC emission: conforming to IEC 61800-3.</li> </ul>																																																								
<b>Product certifications</b>		UL, CSA, GOST, CE, C-TICK																																																								
<b>CE Marking</b>		These variable speed drives have been designed to comply with the essential recommendations of the following European directives: <ul style="list-style-type: none"> <li>- low Voltage Directive 73/23 EC,</li> <li>- EMC Directive 89/336 EC for industrial environments.</li> </ul> To indicate this, Altivar 78 products are marked with the European community CE marking																																																								
<b>Degree of protection</b>		IP 21/NEMA 1 or IP 54/NEMA 12 from <b>ATV 78●U22Y</b> to <b>ATV 78●C16Y</b> IP 54/NEMA 12 kit for IP 21/NEMA 1 products from <b>ATV 78●U22Y</b> to <b>ATV 78●D22Y</b> installable in the field IP 00/ open type from <b>ATV 780C20Y</b> to <b>ATV 780C71Y</b>																																																								
<b>Maximum ambient pollution</b>		Level 2 conforming to IEC 60664-1 and EN 50178																																																								
<b>Maximum relative humidity and Environmental class</b>		95 % without condensation or dripping water, conforming to IEC 60068-2-3 3C2, according to IEC 60721-3-3																																																								
<b>Ambient temperature around the device</b>	Storage	°C - 40...+ 70																																																								
	Operation (with a switching frequency of 1.5 kHz, for a higher frequency see the derating current values below)	°C High torque rating: <ul style="list-style-type: none"> <li>- From <b>ATV 78●U22Y</b> to <b>ATV 78●C16Y</b>: - 10 (no frost)...+ 50</li> <li>- From <b>ATV 780C20Y</b> to <b>ATV 780C71Y</b> or <b>ATV 780FC20Y</b> to <b>ATV 780FC71Y</b>: - 10 (no frost)...+ 40</li> </ul> Standard torque rating: - 10 (no frost)...+ 40																																																								
<b>Derating current values</b>	Inv = max. nominal current of variable speed drive	kHz To operate at a switching frequency from 1.5 to 6, select the motor rating according to the derating current value given in the table below:																																																								
		<table border="1"> <thead> <tr> <th rowspan="2">ATV 78●/ ATV 78●F</th> <th rowspan="2">Ambient Temperature</th> <th colspan="8">Switching frequency (kHz)</th> </tr> <tr> <th>1.5</th> <th>2</th> <th>2.5</th> <th>3</th> <th>3.5</th> <th>4</th> <th>5</th> <th>6</th> </tr> </thead> <tbody> <tr> <td rowspan="2">U22Y to D90Y</td> <td>40 °C</td> <td>Inv</td> <td>Inv</td> <td>Inv</td> <td>Inv</td> <td>Inv</td> <td>0.93</td> <td>0.85</td> <td>0.75</td> </tr> <tr> <td>Inv</td> <td>Inv</td> <td>Inv</td> <td>Inv</td> <td>Inv</td> <td>Inv</td> <td>Inv</td> <td>Inv</td> <td>Inv</td> </tr> <tr> <td rowspan="2">C11Y to C71Y</td> <td>40 °C</td> <td>Inv</td> <td>0.90</td> <td>0.82</td> <td>0.74</td> <td>0.67</td> <td>0.62</td> <td>0.53</td> <td>0.47</td> </tr> <tr> <td>Inv</td> <td>Inv</td> <td>Inv</td> <td>Inv</td> <td>Inv</td> <td>Inv</td> <td>Inv</td> <td>Inv</td> <td>Inv</td> </tr> </tbody> </table>	ATV 78●/ ATV 78●F	Ambient Temperature	Switching frequency (kHz)								1.5	2	2.5	3	3.5	4	5	6	U22Y to D90Y	40 °C	Inv	Inv	Inv	Inv	Inv	0.93	0.85	0.75	Inv	Inv	Inv	Inv	Inv	Inv	Inv	Inv	Inv	C11Y to C71Y	40 °C	Inv	0.90	0.82	0.74	0.67	0.62	0.53	0.47	Inv	Inv	Inv	Inv	Inv	Inv	Inv	Inv	Inv
		ATV 78●/ ATV 78●F			Ambient Temperature	Switching frequency (kHz)																																																				
1.5	2		2.5	3		3.5	4	5	6																																																	
U22Y to D90Y	40 °C	Inv	Inv	Inv	Inv	Inv	0.93	0.85	0.75																																																	
	Inv	Inv	Inv	Inv	Inv	Inv	Inv	Inv	Inv																																																	
C11Y to C71Y	40 °C	Inv	0.90	0.82	0.74	0.67	0.62	0.53	0.47																																																	
	Inv	Inv	Inv	Inv	Inv	Inv	Inv	Inv	Inv																																																	
Hz 5...200 conforming to IEC/EN 50178/60068-2-6 and 60068-2-6 (60068-2-34, -35, -36) Displacement amplitude 3 mm (peak) at 5...10.7 Hz Max acceleration amplitude 0.7 gn at 10.7...200 Hz																																																										
<b>Vibration resistance</b>																																																										
<b>Shock resistance</b>		Conforming to EN 50178/EN 60068-2-27 UPS drop test (for applicable UPS weights) Storage and shipping: max 15 gn, 11 ms (in package)																																																								
<b>Maximum operating altitude</b>		m 1000 without derating 1000...3000 derating the current by 1 % per additional 100 m																																																								
<b>Operating position</b> Maximum permanent angle in relation to the normal vertical mounting position																																																										

# Variable speed drives for asynchronous motors

## Altivar 78

Drive characteristics			
Output frequency range	Hz	0...320 Frequency stability: $\pm 0.01$ % at 50 Hz Resolution: 0.01 Hz	
Switching frequency	kHz	1.5...6, factory default 1.5	
Speed range		1...100 in high torque configuration, 1...1000 close loop vector mode	
Speed accuracy		Without encoder feedback card: - 30 % of nominal slip, speed > 10 % of nominal motor speed, - 50 % of nominal slip, speed < 5 % of nominal motor speed. With encoder feedback in control mode: $\pm 0.01$ % of nominal speed	
Transient overtorque on start-up		200 % of nominal motor torque (typical value $\pm 10$ %) in high torque configuration, 150 % in standard torque configuration	
Maximum transient current		525...690 V: 150 % of nominal current in high torque operation for 60 s then 100 % in continuous operation 110 % of nominal current in standard torque operation (variable torque) for 60 s then 100 % in continuous operation	
Braking torque		Up to 30 % of nominal motor torque without braking unit (typical value) Up to 100 % with external brake resistor	
Control method		<b>ATV 78●●●●Y</b> : flux vector control without sensor; constant torque or variable torque. <b>ATV 78●F●●●Y</b> : flux vector control with sensor for more accurate speed control and torque control	
Electrical characteristics			
3-phase power supply	Voltage	V	525...690 V, $\pm 10$ %
	Frequency	Hz	45...66
Output voltage			Maximum voltage equal to line supply voltage
Efficiency			97.5 % (including line choke losses), at 50/60 Hz at nominal load
Available internal supplies			1 + 10 V output 0...+ 3 %, 10 mA maximum, with short-circuit protection 1 + 24 V output $\pm 15$ %, 150 mA maximum with short-circuit protection
Analogue inputs	AI1		1 analogue voltage input 0...10 V Impedance 200 k $\Omega$ Precision $\pm 1$ % of full scale (10 V) 10-bit resolution
	AI2		1 analogue current input: 0 (4)...20 mA differential Maximum load: 250 $\Omega$ 10-bit resolution
Analogue output	AO		Analogue current output 0 (4)...20 mA with programmable operations Maximum external load < 500 $\Omega$ 10-bit resolution, accuracy $\pm 3$ %
Logic inputs	DI●		6 bipolar inputs: positive or negative logic, $\approx 18$ ... 30 V Programmable operations, impedance > 5 k $\Omega$ State 1 above 18 V, state 0 below 10 V
Auxiliary power supply			Used to supply the control circuit and option cards via an external + 24 V if the main power supply is cut. + 24 V input $\pm 15$ %, 300 mA minimum Separated from the internal power supply by a diode
Output relay			Programmable relay Switching voltage: $\approx 24$ V/6 A, $\sim 250$ V/6 A, $\approx 125$ V/0.4 A Max. continuous current < 2 A RMS Min. switched current 5 V/ 10 mA Electrical isolation between the line supply and the relay power supply
Signalling			Via 3 indicator lamps on the programming terminal, - green power on, - green drive running, - red drive fault.

Protection characteristics		
Overcurrent		Trip limit $4.0 \times I_M$ (nominal drive current) instantaneously
Overvoltage	V	--- 1200
Undervoltage	V	--- 461
Earth fault		In case of earth fault in motor or motor cable, only the frequency converter is protected
Input phase loss		Trips if any of the input phase is missing
Output phase loss		Trips if any of the output phase is missing
Overtemperature	°C	Yes, warning at 85 and trip at 95
Motor thermal overload		Yes, calculation of $I^2 t$
Motor stall		Yes
Motor underload		Yes
Short-circuit protection of + 24 V and + 10 V reference voltage		Yes

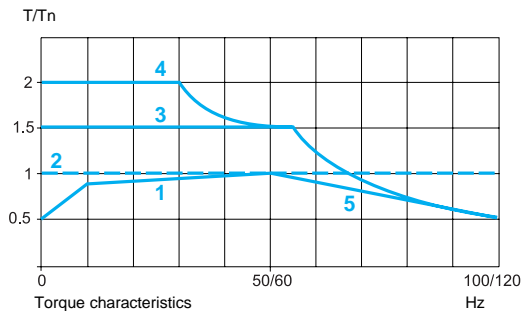

### Torque characteristics (typical curves)

The curve below defines the available continuous torque and transient torque, either on a naturally-cooled or a forced-cooled motor. The only difference is the ability of the motor to provide a high continuous torque at less than half nominal speed.

- 1 Naturally-cooled motor: continuous useful torque
- 2 Force-cooled motor: continuous useful torque (1)
- 3 Transient torque (1)
- 4 Possible overtorque at low speed (1)
- 5 Overspeed torque at constant power (2)

(1) Torque available at zero speed with encoder feedback card.

(2) **Warning:** check with the motor manufacturer regarding the mechanical overspeed possibilities of the selected motor.

### Special uses

#### Motor power rating different from that of speed drive

The variable speed drive can supply any motor which has a power rating between 20 and 120 % of that for which it is designed. Ensure that the current drawn does not exceed the continuous output current of the drive.

#### Motors connected in parallel

The variable speed drive rating must be greater than the sum of the motor currents to be connected to the variable speed drive. In this case, external thermal protection must be provided for each motor by probes (up to 6 motors) or a thermal overload relay.

If the total length of the cables is greater than 30 m (100 feet), the fitting of a line choke between the variable speed drive and the motor is recommended (dv/dt filter is recommended at 525/660/690 V).

Autotuning is necessary for applications which require a high start-up torque (conveyors, lifting). In this case, the motors should be mechanically coupled, should have the same power rating and the same cable length.

Autotuning is not necessary for applications which do not require a high start-up torque (pumps, fans). In this case, the motor power ratings and the cable lengths may be different.

Each motor can be isolated by a contactor during operation. On the other hand, the motor should be reconnected to the variable speed drive in accordance with the precautions described below: "Coupling a contactor downstream of the variable speed drive".

The nominal current set for the variable speed drive should be equal to the sum of the motor currents.

#### Coupling a motor downstream of the speed drive

Connecting on the fly is possible if the current peak of the motor to be connected is less than the current supported by the variable speed drive at the time of coupling. In all cases it is preferable to lock the variable speed drive before closing the contactor and unlock it after closing the main poles of the contactors.

#### Connection to an IT network

This type of connection is possible, but radio interference filters cannot be mounted. In addition, if the stray capacitance (or the filter capacitors) between the network and earth are excessive, there is a risk of premature wear on the variable speed drive in the event of a prolonged earth fault.

# Variable speed drives for asynchronous motors

## Altivar 78



ATV 782D11Y



ATV 782C16Y

### High torque applications (150 % Tn)

Motor				Altivar 78				Reference (5) (6)	Weight (7)
Power rating on motor plate				Input/output current (1)		Transient output current (4)	Power dissipated at nominal load		
525 V	575 V	660 V	690 V	Nominal drive current (2)	150 % overload current (3)			A	W
kW	HP	kW	kW	A	A	A	W	kg	
<b>3-phase power supply voltage 525 V - 10 %...690 V + 10 % 50/60 Hz</b>									
1.7	2	2.1	2.2	3.2	4.8	6.4	97	ATV 78●U22Y	18.500
2.3	3	2.9	3	4.5	6.8	9	111	ATV 78●U30Y	18.500
3	—	3.8	4	5.5	8.3	11	126	ATV 78●U40Y	18.500
4.2	5	5.3	5.5	7.5	11.3	15	170	ATV 78●U55Y	18.500
5.7	7,5	7.2	7.5	10	15	20	193	ATV 78●U75Y	18.500
8	10	11	11	13.5	20.3	27	295	ATV 78●D11Y	18.500
11	15	14	15	18	27	36	414	ATV 78●D15Y	18.500
14	20	18	18,5	22	33	44	450	ATV 78●D18Y	18.500
17	25	21	22	27	41	54	520	ATV 78●D22Y	18.500
23	30	29	30	34	51	68	630	ATV 78●D30Y	35.000
29	40	36	37	41	62	82	791	ATV 78●D37Y	35.000
34	50	43	45	52	78	104	1039	ATV 78●D45Y	58.000
42	60	53	55	62	93	124	1396	ATV 78●D55Y	58.000
57	75	72	75	80	120	160	2144	ATV 78●D75Y	58.000
68	100	86	90	100	150	200	2015	ATV 78●D90Y	146.000
84	125	105	110	125	188	213	2687	ATV 78●C11Y	146.000
100	150	126	132	144	216	245	3123	ATV 78●C13Y	146.000
122	—	153	160	170	255	289	3707	ATV 78●C16Y	146.000
152	200	191	200	208	312	375	3971	ATV 780C20Y (8)	176.000
190	250	239	250	261	392	470	5157	ATV 780C25Y (8)	207.000
240	300	301	315	325	488	585	6016	ATV 780C31Y (8)	207.000
270	400	340	355	385	578	693	6410	ATV 780C35Y (8)	335.000
342	450	430	450	460	690	828	7401	ATV 780C45Y (8)	335.000
380	500	478	500	502	753	903.6	8058	ATV 780C50Y (8)	378.000
426	600	536	560	590	885	1062	8400	ATV 780C56Y (8)	414.000
479	650	603	630	650	975	1170	9450	ATV 780C63Y (8)	414.000
540	800	679	710	650	975	1170	10 650	ATV 780C71Y (8)	414.000

### High torque applications with integrated encoder feedback card

In the hereabove references, replace **ATV 78●** with **ATV 78●F**.

Example : **ATV 78●U22Y** becomes **ATV 78●FU22Y**, **ATV 780C71Y** becomes **ATV 780FC71Y**.

(1) The input and output current values are about the same at nominal speed and nominal load.

(2) The current rating is according to a standard 4 poles class B motor.

(3) 150 % current overload for 1 minute every 10 minutes.

(4) Transient output current for 2 seconds every 20 seconds.

(5) In the reference, replace the ● with **2** for a drive IP 21 (NEMA type 1) or **5** for a drive IP 54 (NEMA type 12).

Example : **ATV 782U22Y** for IP 21 or **ATV 785U22Y** for IP 54.

From **ATV 780C20Y** to **ATV 780C71Y**, the product is only available in IP 00 (open type) from the factory.

(6) The conformal coating is available by adding suffix **S337** to part number from **ATV 785U22Y** to **ATV 785C16Y** and **ATV 780C20Y** to **ATV 780C71Y**. Examples: **ATV 785D75Y** becomes **ATV 785D75YS337**.

(7) The weight includes drive and line choke.

(8) The line chokes are supplied with the variable speed drives, but not integrated.



# Variable speed drives for asynchronous motors

## Altivar 78



ATV 782D11Y



ATV 782C16Y

### Standard torque applications (110 % Tn)

Motor				Altivar 78				Reference (5) (6)	Weight (7)
Power rating on motor plate				Input/output current (1)		Transient output current (4)	Power dissipated at nominal load		
525 V	575 V	660 V	690 V	Nominal drive current (2)	110 % overload current (3)			A	W
kW	HP	kW	kW	A	A	A	W		
<b>3-phase power supply voltage 525 V - 10 %...690 V + 10 % 50/60 Hz</b>									
2.3	3	2.9	3	4.5	5	6.4	104	ATV 78●U22Y	18.500
3	–	3.8	4	5.5	6.1	9	118	ATV 78●U30Y	18.500
4.2	5	5.3	5.5	7.5	8.3	11	141	ATV 78●U40Y	18.500
5.7	7.5	7.2	7.5	10	11	15	190	ATV 78●U55Y	18.500
8	10	11	11	13	14.9	20	227	ATV 78●U75Y	18.500
11	15	14	15	18	19.8	27	342	ATV 78●D11Y	18.500
14	20	18	18.5	22	24.2	36	455	ATV 78●D15Y	18.500
17	25	21	22	27	29.7	44	483	ATV 78●D18Y	18.500
23	30	29	30	34	37.4	54	614	ATV 78●D22Y	18.500
29	40	36	37	41	45.1	68	712	ATV 78●D30Y	35.000
34	50	43	45	52	57.2	82	901	ATV 78●D37Y	35.000
42	60	53	55	62	68.2	104	1160	ATV 78●D45Y	58.000
57	75	72	75	80	88	124	1670	ATV 78●D55Y	58.000
68	100	86	90	100	110	160	2345	ATV 78●D75Y	58.000
84	125	105	110	125	138	200	2286	ATV 78●D90Y	146.000
100	150	126	132	144	158	213	2998	ATV 78●C11Y	146.000
122	–	153	160	170	187	245	3639	ATV 78●C13Y	146.000
152	200	191	200	208	229	289	4263	ATV 78●C16Y	146.000
190	250	239	250	261	287	375	4803	ATV 780C20Y (8)	176.000
240	300	301	315	325	358	470	5660	ATV 780C25Y (8)	207.000
270	400	340	355	385	424	585	7089	ATV 780C31Y (8)	207.000
342	450	430	450	460	506	693	7377	ATV 780C35Y (8)	335.000
380	500	478	500	502	552	828	8635	ATV 780C45Y (8)	335.000
426	600	536	560	590	649	903.6	9201	ATV 780C50Y (8)	378.000
479	650	603	630	650	715	1062	9450	ATV 780C56Y (8)	414.000
540	800	679	710	650	825	1170	10 650	ATV 780C63Y (8)	414.000
609	800	765	800	820	902	1170	12 000	ATV 780C71Y (8)	414.000

(1) The input and output current values are about the same at nominal speed and nominal load.

(2) The current rating is according to a standard 4 poles class B motor.

(3) 150 % current overload for 1 minute every 10 minutes.

(4) Transient output current for 2 seconds every 20 seconds.

(5) In the reference, replace the ● with 2 for a drive IP 21 (NEMA type 1) or 5 for a drive IP 54 (NEMA type 12).

Example : ATV 782U22Y for IP 21 or ATV 785U22Y for IP 54.

From ATV 780C20Y to ATV 780C71Y, the product is only available in IP 00 (open type) from the factory.

(6) The conformal coating is available by adding suffix S337 to part number from ATV 785U22Y to ATV 785C16Y and ATV 780C20Y to ATV 780C71Y. Examples: ATV 785D75Y becomes ATV 785D75YS337.

(7) The weight includes drive and line choke.

(8) The line chokes are supplied with the variable speed drives, but not integrated.

# Variable speed drives for asynchronous motors

## Altivar 78

### Reduction of harmonic currents

The main solutions for reducing harmonic currents are as follows:

- line chokes (supplied with the Altivar 78),
- passive filters,
- active compensators, also called Accusine active filters are marketed under the Merlin Gerin brand,
- hybrid filters.

All four solutions can be used on the same installation. It is always easier and less expensive to handle the harmonics at installation level as a whole rather than at the level of each individual unit, particularly when using passive filters and active compensators.

#### Line chokes

##### Presentation

The Altivar 78 has integrated line chokes to help reduce the current harmonic distortion generated by the variable speed drive itself and help improve protection against overvoltages on the line supply. The integrated line chokes in the Altivar 78 are also used to minimize the line current.

The use of line chokes is especially recommended in the following cases:

- close connection of several variable speed drives in parallel,
- line supply with significant interference from other equipment (interference, overvoltages, switching capacitors),
- line supply with a voltage imbalance between phases > 1.8 % of nominal voltage,
- line supply with a low impedance, e.g. the KVA of supply transformer is 10 times greater than the input KVA of the variable speed drive,
- installation of a large number of variable speed drives on the same power supply,
- if a power factor correction unit is installed, the line choke reduces the overload of the power factor (cos φ) correction capacitors and limits the voltage spikes caused by capacitor switching.

#### Example of currents and harmonic levels at 690 V, 50 Hz

Variable speed drives	H1		H5		H7		H11		H13	
	at 150 % Tn	at 110 % Tn	at 150 % Tn	at 110 % Tn	at 150 % Tn	at 110 % Tn	at 150 % Tn	at 110 % Tn	at 150 % Tn	at 110 % Tn
	A	A	A	A	A	A	A	A	A	A
ATV 78●U22Y, ●FU22Y	1.84	2.51	72.46	69.11	51.65	45.19	14.86	9.13	6.42	5.96
ATV 78●U30Y, ●FU30Y	2.51	3.35	69.11	69.10	45.19	45.45	9.13	10.29	5.96	6.53
ATV 78●U40Y, ●FU40Y	3.35	4.60	69.10	65.82	45.45	39.84	10.29	5.94	6.53	5.21
ATV 78●U55Y, ●FU55Y	4.60	6.28	65.82	63.58	39.84	36.49	5.94	5.89	5.21	5.80
ATV 78●U75Y, ●FU75Y	6.28	9.20	63.58	57.32	36.49	30.32	5.89	7.21	5.80	7.07
ATV 78●D11Y, ●FD11Y	9.20	12.55	57.32	45.73	30.32	22.68	7.21	6.20	7.07	4.96
ATV 78●D15Y, ●FD15Y	12.55	15.48	45.73	43.45	22.68	21.53	6.20	6.09	4.96	5.68
ATV 78●D18Y, ●FD18Y	15.48	18.41	43.45	41.32	21.53	17.83	6.09	6.15	5.68	5.17
ATV 78●D22Y, ●FD22Y	18.41	25.10	41.32	34.43	17.83	11.99	6.15	5.13	5.17	4.50
ATV 78●D30Y, ●FD30Y	25.10	31.38	45.91	40.78	21.76	17.02	6.61	5.93	5.75	4.64
ATV 78●D37Y, ●FD37Y	31.38	37.65	40.78	37.82	17.02	15.20	5.93	5.75	4.64	4.97
ATV 78●D45Y, ●FD45Y	37.65	46.02	43.42	38.00	19.82	16.32	6.49	5.51	4.92	4.67
ATV 78●D55Y, ●FD55Y	46.02	62.76	38.00	35.30	16.32	13.58	5.51	5.85	4.67	4.46
ATV 78●D75Y, ●FD75Y	62.76	75.31	35.30	32.22	13.58	10.63	5.85	5.64	4.46	4.08
ATV 78●D90Y, ●FD90Y	75.31	92.04	32.22	32.09	10.63	9.29	5.64	5.92	4.08	3.39
ATV 78●C11Y, ●FC11Y	92.04	110.45	38.32	36.03	15.87	13.19	5.81	6.03	5.05	4.29
ATV 78●C13Y, ●FC13Y	110.45	133.88	36.03	33.39	13.19	10.30	6.03	5.63	4.29	3.92
ATV 78●C16Y, ●FC16Y	133.88	167.35	33.39	31.74	10.30	9.65	5.63	5.72	3.92	3.53
ATV 780C20Y, 0FC20Y	167.35	209.18	37.69	35.58	16.62	10.90	6.29	5.97	3.94	3.56
ATV 780C25Y, 0FC25Y	209.18	263.57	40.05	34.87	15.27	11.65	5.95	5.33	4.19	3.94
ATV 780C31Y, 0FC31Y	263.57	297.04	34.87	33.90	11.65	11.28	5.33	5.00	3.94	3.98
ATV 780C35Y, 0FC35Y	297.04	376.53	43.10	39.70	18.10	14.70	7.20	7.00	3.90	3.30
ATV 780C45Y, 0FC45Y	376.53	418.37	39.70	38.40	14.70	13.40	7.00	6.90	3.30	3.20
ATV 780C50Y, 0FC50Y	418.37	468.57	46.70	44.90	21.10	19.20	6.90	6.80	4.10	3.70
ATV 780C56Y, 0FC56Y	468.57	527.15	43.00	41.30	17.60	15.90	7.00	6.90	3.70	3.40
ATV 780C63Y, 0FC63Y	527.15	594.09	41.30	39.80	15.90	14.30	6.90	6.90	3.40	3.20
ATV 780C71Y, 0FC71Y	527.15	669.39	41.30	38.10	15.90	12.90	6.90	6.80	3.40	3.20

#### Line chokes (continued)

##### Characteristics

Variable speed drives	Nominal current (In) (1)		Line choke								
	at 150 % Tn	at 110 % Tn	Inductance value	Impedance value with In at 150 % Tn (high torque application)				Impedance value with In at 110 % Tn (standard torque application)			
				525 V 60 Hz	575 V 60 Hz	660 V 50 Hz	690 V 50 Hz	525 V 60 Hz	575 V 60 Hz	660 V 50 Hz	690 V 50 Hz
	A	A	μH	%	%	%	%	%	%	%	%
ATV 78●U22Y, ●FU22Y	3	4	1500	0.44	0.40	0.29	0.28	0.60	0.55	0.40	0.38
ATV 78●U30Y, ●FU30Y	4	5	1500	0.60	0.55	0.40	0.38	0.80	0.73	0.53	0.51
ATV 78●U40Y, ●FU40Y	5	7	1500	0.80	0.73	0.53	0.51	1.10	1.01	0.73	0.70
ATV 78●U55Y, ●FU55Y	7	10	1500	1.10	1.01	0.73	0.70	1.50	1.37	1.00	0.95
ATV 78●U75Y, ●FU75Y	10	13	1500	1.50	1.37	1.00	0.95	2.20	2.01	1.46	1.40
ATV 78●D11Y, ●FD11Y	13	18	1500	2.20	2.01	1.46	1.40	3.00	2.74	1.99	1.90
ATV 78●D15Y, ●FD15Y	18	22	1500	3.00	2.74	1.99	1.90	3.71	3.38	2.46	2.35
ATV 78●D18Y, ●FD18Y	22	27	1500	3.71	3.38	2.46	2.35	4.41	4.02	2.92	2.79
ATV 78●D22Y, ●FD22Y	27	34	1500	4.41	4.02	2.92	2.79	6.01	5.49	3.98	3.81
ATV 78●D30Y, ●FD30Y	34	41	880	3.52	3.22	2.34	2.24	4.41	4.02	2.92	2.79
ATV 78●D37Y, ●FD37Y	41	52	880	4.41	4.02	2.92	2.79	5.29	4.83	3.50	3.35
ATV 78●D45Y, ●FD45Y	52	62	880	5.29	4.83	3.50	3.35	6.46	5.90	4.28	4.10
ATV 78●D55Y, ●FD55Y	62	80	575	4.22	3.86	2.80	2.68	5.76	5.26	3.82	3.65
ATV 78●D75Y, ●FD75Y	80	100	575	5.76	5.26	3.82	3.65	6.91	6.31	4.58	4.38
ATV 78●D90Y, ●FD90Y	100	125	300	3.61	3.29	2.39	2.29	4.41	4.02	2.92	2.79
ATV 78●C11Y, ●FC11Y	125	144	300	4.41	4.02	2.92	2.79	5.29	4.83	3.50	3.35
ATV 78●C13Y, ●FC13Y	144	170	300	5.29	4.83	3.50	3.35	6.41	5.85	4.25	4.06
ATV 78●C16Y, ●FC16Y	170	208	300	6.41	5.85	4.25	4.06	8.01	7.31	5.31	5.08
ATV 780C20Y, 0FC20Y	208	261	187	4.99	4.56	3.31	3.17	6.24	5.70	4.14	3.96
ATV 780C25Y, 0FC25Y	261	325	126	4.21	3.84	2.79	2.67	5.30	4.84	3.51	3.36
ATV 780C31Y, 0FC31Y	325	385	126	5.30	4.84	3.51	3.36	5.97	5.45	3.96	3.79
ATV 780C35Y, 0FC35Y	416	460	95	4.50	4.11	2.98	2.86	5.71	5.21	3.78	3.62
ATV 780C45Y, 0FC45Y	460	502	95	5.71	5.21	3.78	3.62	6.34	5.79	4.20	4.02
ATV 780C50Y, 0FC50Y	502	590	63	4.21	3.84	2.79	2.67	4.71	4.30	3.12	2.99
ATV 780C56Y, 0FC56Y	590	650	63	4.71	4.30	3.12	2.99	5.30	4.84	3.51	3.36
ATV 780C63Y, 0FC63Y	650	750	63	5.30	4.84	3.51	3.36	5.97	5.45	3.96	3.79
ATV 780C71Y, 0FC71Y	750	820	63	5.97	5.45	3.96	3.79	6.73	6.14	4.46	4.27

(1) In is the nominal output current rating of variable speed drive in standard torque applications (110 % Tn) or in high torque applications (150 % Tn).

#### Passive filters

##### Presentation

These work by "trapping" harmonic currents in LC circuits linked to the harmonic numbers to be filtered. The filter thus consists of "steps", each step corresponding to a harmonic number. Numbers 5 and 7 are the most commonly filtered.

The filter can be installed for a load or for a group of loads. Its design requires a detailed analysis of the supply and a research project. Its size depends on the harmonic range of the load and the impedance of the source.

This type of filtering depends entirely on the source and the loads. It therefore offers very little flexibility and almost no opportunity for upgrading the installation.

**Note:** this type of filter can also be used to eliminate harmonic distortion which already exists on the line supply. Please consult your Regional Sales Office.

#### Active compensators

##### Presentation

These compensators, connected in parallel on the load and on the line supply, measure harmonic currents emitted by the equipment and automatically generate inverse harmonic currents.

The advantages are as follows:

- independence in relation to the load and to the supply impedance,
- adaptive tuning.

**Note:** please consult your Regional Sales Office.

#### Hybrid filters

##### Presentation

The hybrid filter is a device which comprises a passive filter and an active compensator and provides an excellent compromise for handling harmonics.

**Note:** please consult your Regional Sales Office.

# Variable speed drives for asynchronous motors

Altivar 78

Options: dv/dt long lead filters

## Presentation

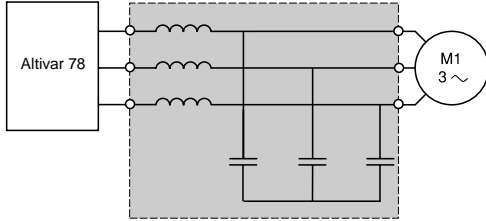

dv/dt long lead filter

dv/dt are the steep-front voltage pulses that travel down the long leads in the circuit to the motor and subsequently revert back in a "reflected wave".

When the conductors are long enough, usually 30 metres (100 feet) or more, the time for reflection matches the time for transmission resulting in a high amplitude "standing wave" on the circuit. Voltage spikes of up to 2100 volts are frequently experienced for  $\sim$  525/660/690 V systems, and equipment failures are the result. It is imperative to use the dv/dt filter.

Installed between the variable speed drive and motor, dv/dt filter provides protection for the motor by slowing the rate of voltage increase and minimizing the peak voltage that occurs at the motor terminals.

## References

For variable speed drives	Maxi. length of cable		dv/dt for $\sim$ 525/660/690 V		Reference	Weight
	Shielded	Unshielded	Nominal current	Max. loss		
	m	m	A	W		kg
ATV 78●U22Y...●D15Y ATV 78●FU22Y...●FD15Y	100	140	25	90	VW3 A78601C	7
ATV 78●D18Y...●D31Y ATV 78●FD18Y...●FD31Y	100	210	55	120	VW3 A78602C	12
ATV 78●D45Y...●D55Y ATV 78●FD45Y...●FD55Y	150	210	80	140	VW3 A78603C	15
ATV 78●D75Y...●D90Y ATV 78●FD75Y...●FD90Y	150	280	130	190	VW3 A78604C	23
ATV 78●C11Y...●C16Y ATV 78●FC11Y...●FC16Y	200	280	210	210	VW3 A78605C	35
ATV 780C20Y ATV 780FC20Y	200	350	280	350	VW3 A78606C	60
ATV 780C25Y ATV 780FC25Y	250	350	350	480	VW3 A78607C	70
ATV 780C31Y ATV 780FC31Y	250	350	420	650	VW3 A78608C	85
ATV 780C35Y...0C50Y ATV 780FC35Y...0FC50Y	250	420	600	850	VW3 A78609C	120
ATV 780C56Y...0C71Y ATV 780FC56Y...0FC71Y	300	420	820	1050	VW3 A78610C	140

# Variable speed drives for asynchronous motors

Altivar 78

Options: output chokes

---

## Presentation

The use of an output chokes between the drive and the motor is recommended for motor cables which are longer than 10 metres (30 feet).

This makes it possible to:

- limit  $dv/dt$ ,
- limit overvoltage on the motor terminal,
- limit "reflected wave" from the motor back to the variable speed drive,
- filter interference caused by opening a contactor placed between the reactor and the motor,
- reduce the motor earth leakage current.

*Note: please consult your Regional Sales Office.*

# Variable speed drives for asynchronous motors

Altivar 78

Options: braking resistors

## Presentation

The dynamic braking transistor and braking resistor allow the Altivar 78 variable speed drive to function in quadrants 2 and 4 of the four-quadrant speed/torque curve. In these quadrants of motor operation, the motor is essentially a generator through which energy is transferred from the motor load back to the variable speed drive. This results in elevated DC bus voltage to the variable speed drive, which may cause it to shut down to protect itself.

Braking resistors are commonly used to dissipate the excess energy generated by the motor operating in this mode. The flow of current to the braking resistor is controlled by the dynamic braking transistor.

The dynamic braking transistor is integrated in the Altivar 78 from 2.2 to 160 kW (2 to 150 HP), and externally mounted from 200 to 710 kW (200 to 800 HP).

## Characteristics

Type of braking resistors			VW3 A78701L ...A78703L	VW3 A78704L and A78705L	VW3 A78706L and A78707L	VW3 A78701H ...A78703H	VW3 A78704H ...A78707H
Ambient air temperature around the device	Storage	°C	- 40...+ 70				
	Operation	°C	- 40...+ 40 without derating Up to 80 °C with current derating of 2.5 % per °C above 40				
Degree of protection of enclosure	If vertical mounting		IP 50	IP 21	IP 20	IP 21	IP 20
	In other cases		IP 50	IP 20	IP 20	IP 20	IP 20
Thermal protection			-				Via temperature controlled switch
Temperature controlled switch	Tripping temperature	°C	220				

# Variable speed drives for asynchronous motors

## Altivar 78

### Options: braking resistors

#### Braking resistors

For variable speed drives	Braking resistors				
	Minimum ohmic value at 20° (1)	Power continuous	Number of resistors required per drive	Reference	Weight
	$\Omega$	kW			kg
<b>Braking time 5 s (2)</b>					
ATV 78●U22Y...●U75Y ATV 78●FU22Y...●FU75Y	100	0.3	1	VW3 A78701L	1.700
ATV 78●D11Y...●D22Y ATV 78●FD11Y...●FD22Y	30	1.0	1	VW3 A78702L	4.000
ATV 78●D30Y...●D37Y ATV 78●FD30Y...●FD37Y	18	1.7	1	VW3 A78703L	7.000
ATV 78●D45Y...●D75Y (3) ATV 78●FD45Y...●FD75Y (3)	9	3.2	1	VW3 A78704L	16.000
ATV 78●D90Y...●C16Y (3) ATV 78●FD90Y...●FC16Y (3)	7	4	1	VW3 A78705L	28.000
ATV 780C20Y...0C31Y and ATV 780FC20Y...0FC31Y	2.5	11	1	VW3 A78706L	57.000
ATV 780C35Y...0C50Y and ATV 780FC35Y...0FC50Y	1.7	17	1	VW3 A78707L	86.000
ATV 780C56Y...0C71Y and ATV 780FC56Y...0FC71Y	2.5	11	2	VW3 A78706L	114.000
<b>Braking time 10 s (2)</b>					
ATV 78●U22Y...●U75Y ATV 78●FU22Y...●FU75Y	100	0.79	1	VW3 A78701H	7.000
ATV 78●D11Y...●D22Y ATV 78●FD11Y...●FD22Y	30	2.8	1	VW3 A78702H	14.000
ATV 78●D30Y...●D37Y ATV 78●FD30Y...●FD37Y	18	5.5	1	VW3 A78703H	33.000
ATV 78●D45Y...●D75Y (3) ATV 78●FD45Y...●FD75Y (3)	9	9.4	1	VW3 A78704H	46.000
ATV 78●D90Y...●C16Y (3) ATV 78●FD90Y...●FC16Y (3)	7	12	1	VW3 A78705H	55.000
ATV 780C20Y...0C31Y and ATV 780FC20Y...0FC31Y	2.5	34	1	VW3 A78706H	160.000
ATV 780C35Y...0C50Y and ATV 780FC35Y...0FC50Y	1.7	50	1	VW3 A78707H	230.000
ATV 780C56Y...0C71Y and ATV 780FC56Y...0FC71Y	2.5	34	2	VW3 A78706H	320.000
<b>Braking resistor connection kit</b>					
For variable speed drives				Reference	Weight
ATV 78●D45Y...●C16Y ATV 78●FD45Y...●FC16Y				VW3 A78810	1.250

(1) Do not use a resistor with a value less than the minimum value given in the table.

(2) For special applications such as hoisting, please refer to the curves (see pages 60627/4 and 60627/5).

(3) Braking resistor connection kit VW3 A78810 must be used.

# Variable speed drives for asynchronous motors

## Altivar 78

Options: braking resistors

### Determining the braking power

Calculating the braking time from the inertia

$$t_b = \frac{J \cdot \omega}{T_b + T_r}$$

$$\omega = \frac{2\pi \cdot n}{60}$$

$$T_b = \frac{\Sigma J \cdot (n_1 - n_2)}{9,55 \cdot t_b}$$

$$\hat{P}_b = \frac{T_b \cdot n_1}{9,55}$$

$$\bar{P}_b = \frac{\hat{P}_b}{2}$$

$T_b$	Motor braking torque
$\Sigma J$	Total inertia applied to the motor
$n_1$	Motor speed ahead of gearbox
$n_2$	Motor speed after gearbox
$t_b$	Braking time
$\hat{P}_b$	Peak braking power
$\bar{P}_b$	Average braking power during time $t_b$
$T_r$	Braking torque

[Nm]
[kgm <sup>2</sup> ]
[rpm]
[rpm]
[s]
[W]
[W]
[mN]

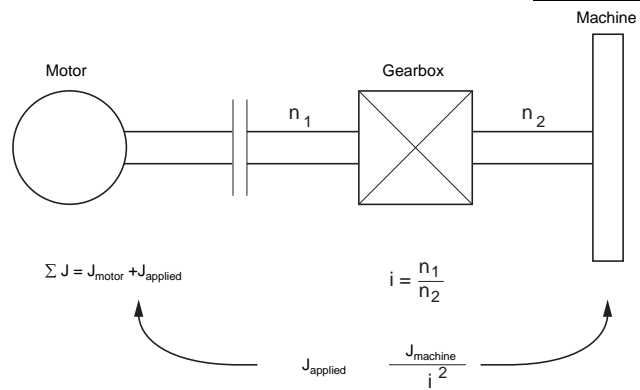

### Braking power of a load moving horizontally with constant deceleration (eg.: carriage)

$W$	Kinetic energy
$w$	Weight
$v$	Speed
$t_b$	Braking time
$\hat{P}_b$	Peak braking power
$\bar{P}_b$	Average braking power during time $t_b$
$T_b$	Braking torque
$n$	Motor speed

[Joule]
[kg]
[m/s]
[s]
[W]
[W]
[Nm]
[rpm]

$$W = \frac{w \cdot v^2}{2}$$

$$\bar{P}_f = \frac{W}{t_b}$$

$$\hat{P}_b = \bar{P}_b \cdot 2$$

### Braking power for an active load (eg.: test bench)

$$\bar{P}_b = \frac{T_b \cdot n}{9,55}$$

### Braking power for a downward vertical movement

$g$	Acceleration	9.81 m/s <sup>2</sup>
$a$	Deceleration	[m/s <sup>2</sup> ]
$v$	Linear downward speed	[m/s]
$J$	Moment of inertia	[kgms <sup>2</sup> ]
$\omega$	Angular speed	[rad/s]
$t_b$	Downward stopping time	[s]

$$\bar{P}_b = w \cdot g \cdot v$$

$$\hat{P}_b = w \cdot (g + a) \cdot v + \frac{J \cdot \omega^2}{t_b}$$

$$\omega = \frac{2\pi \cdot n}{60}$$

All the braking power calculations are only true if it is assumed that there are no losses ( $\eta = 1$ ) and that there is no resistive torque.

Since all these points are important, an accurate assumption must be made:

- Losses in the system,
- The losses generated in the motor (working as a generator, quadrants II and IV) are of some help during the braking phase. Without exception, efficiency must be calculated to the braking power squared,
- Resistive torque,
- There may sometimes be resistive torque related to mechanical friction, air and opposing quadratic torque of the fans,
- These phenomena, which are rarely taken into consideration, reduce the braking power, The resistive torque or the power should be deduced from the calculated braking power,
- Driving torque.

Additional phenomena, such as the wind, may cause an increase in the braking power. These phenomena should be taken into consideration.

The required braking power is calculated as follows:

$$\hat{P}_{bR} = (\hat{P}_b - P_{load}) \times \eta_{total}^2$$

$$\bar{P}_{bR} = (\bar{P}_b - P_{load}) \times \eta_{total}^2$$

$$\eta_{total} = \eta_{mec} \times \eta_{mot} \times 0,98$$

$\hat{P}_{bR}$	Maximum actual braking power	[W]
$\bar{P}_{bR}$	Continuous actual braking power	[W]
$\eta_{total}$	Total efficiency	
$P_{load}$	Braking power connected with the resistive or [W] driving torque (not taken into account in the calculation). $P_{load}$ can be positive or negative.	
$\eta_{drive}$	Drive efficiency = 0.98	
$\eta_{mec}$	Mechanical efficiency	
$\eta_{mot}$	Motor efficiency	



# Variable speed drives for asynchronous motors

## Altivar 78

### Options: braking resistors

$\hat{P}_{max}$	Maximum braking power available with the braking unit	[W]
$P_{contin}$	Permanent thermal braking power	[W]
$U_d$	Braking unit control level	[V]
$I$	Braking resistor thermal current (see the TH setting)	[A]
$P_{cycle}$	See the braking cycle diagram	

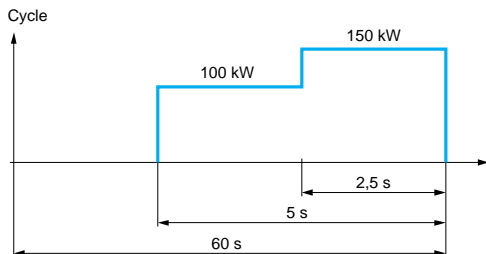

Example of selection of a braking resistance for a hosting application

To select the braking power ( $\hat{P}_b, \overline{P}_b$ ) it is also necessary to consider the following points when selecting the braking option:

- Type of installation and protection of the braking resistors,
- Wiring conditions,
- Problems with heat dissipation (air conditioning),
- Cost and possibility of depreciation of the installation due to the reduced costs of electrical energy.

**For braking, the braking resistor is selected to match the required power and the braking cycle.**

In general :

$$\hat{P}_{max} = \frac{U_d^2}{R}$$

⚠ The drive has a protection device inside the braking resistor. See parameters of setting-up E3.06, E3.07 and E3.08.

The protection curve and other advice is given in the programming guide.

If this protection curve is suitable for your braking resistors, then it is possible to use the internal protection. If not, external protection must be provided by a thermal overload relay.

Thermal overload relay

$P$  = nominal braking resistor power

$R$  = value of the resistor

$$P = R I^2 \rightarrow I = \sqrt{\frac{P}{R}} = \text{thermal overload relay rated value}$$

In the formula, we have:  $\hat{P}_{max} = \frac{U_d^2}{R}$

$$\hat{P}_{max} = \text{Braking unit power} + R$$

$$P_{continuous} = I^2 R \text{ (Resistor P)}$$

**Customer data:** Raising/lowering cycle = **1 minute**

$Cd/Cn = 1,38$

Raising with rated load at steady state: **106 kW**

$\eta_{total} = 0,85$

**Calculations:**

106 kW leads to selection of a 120 kW motor

$120 \text{ kW} \times 0,85 = 102 \text{ kW} \rightarrow 100 \text{ kW}$  braking at steady state

$102 \text{ kW} \times 1,38 = 140 \text{ kW} \rightarrow$  selection of 150 kW max braking power

The speed drive used is a 132 kW **ATV 782C13Y** (min. braking resistance = 9  $\Omega$ )

The minimum resistance to be used is determined as a function of the speed drive used with the aid of braking resistance cycle curves.

Braking cycle: 60 s = 150 kW max. for 2.5 s and 100 kW for 5 s.

Braking resistance **VW3 A78705H** can be used since it accepts 100 kW for more than 5 s and 150 kW for 2.5 s.

# Variable speed drives for asynchronous motors

Altivar 78

Characteristics curves of braking resistors

## Permissible overload per braking resistor according to time

**VW3 A78701L (P continuous = 0.3 kW)**

**VW3 A78702L (P continuous = 1.0 kW)**

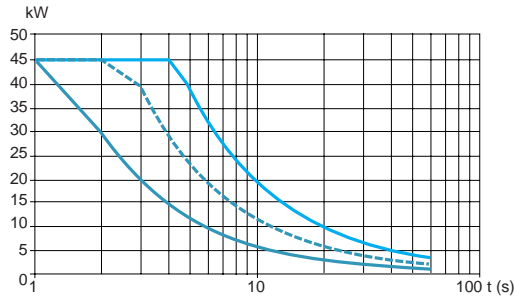
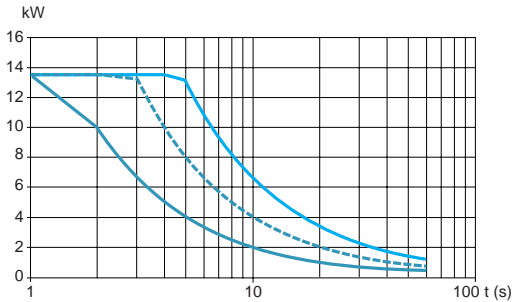

**VW3 A78703L (P continuous = 1.7 kW)**

**VW3 A78704L (P continuous = 3.2 kW)**

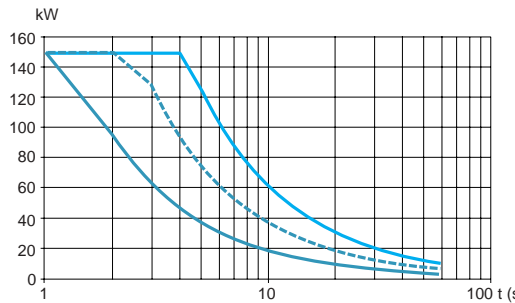
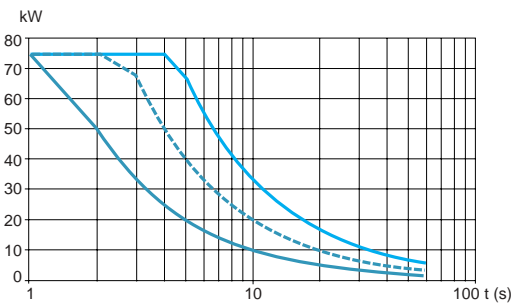

**VW3 A78705L (P continuous = 4.0 kW)**

**VW3 A78706L (P continuous = 11 kW)**

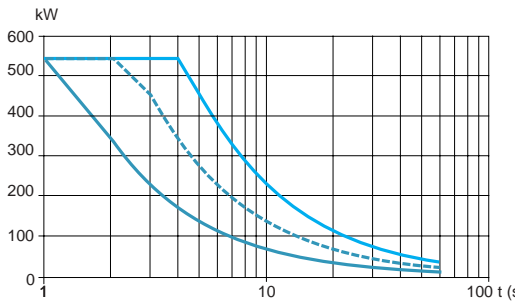
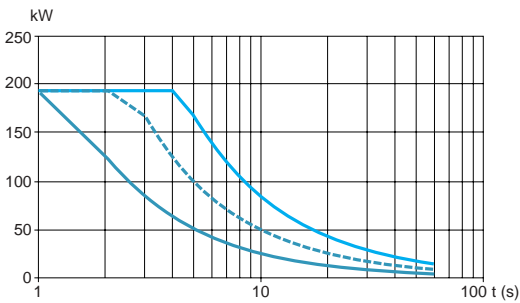

**VW3 A78707L (P continuous = 17 kW)**

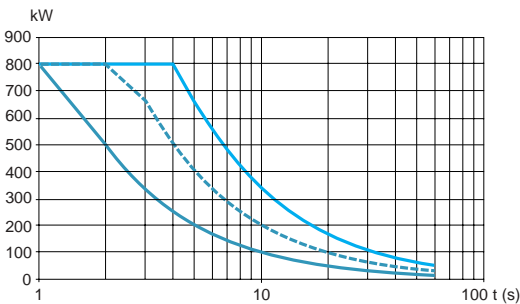

— P max (60 s cycle)  
 - - - P max (120 s cycle)  
 — P max (200 s cycle)

# Variable speed drives for asynchronous motors

Altivar 78

Characteristics curves of braking resistors

## Permissible overload per braking resistor according to time (continued)

VW3 A78701H (P continuous = 0.79 kW)

VW3 A78702H (P continuous = 2.8 kW)

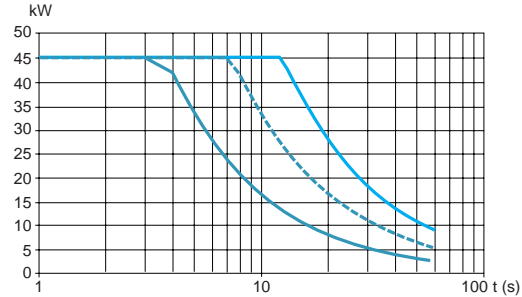
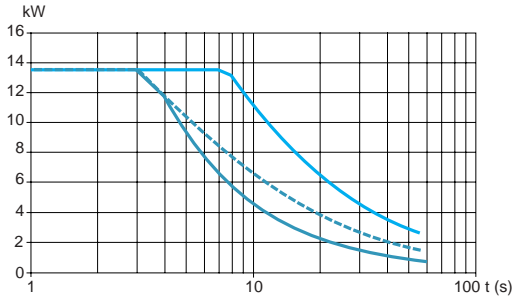

VW3 A78703H (P continuous = 5.5 kW)

VW3 A78704H (P continuous = 9.4 kW)

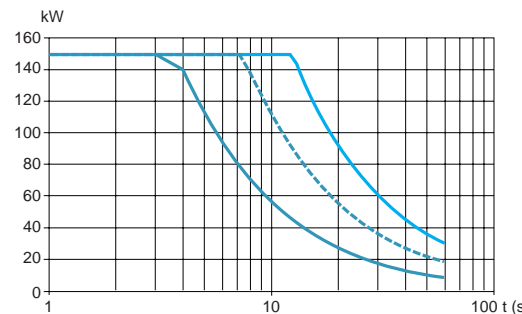
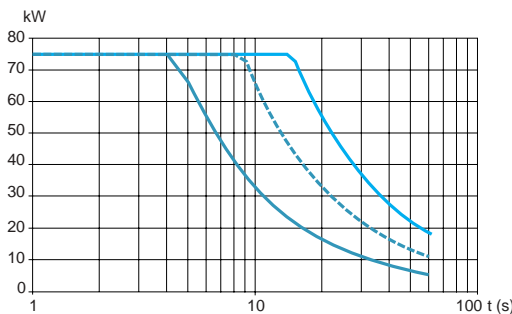

VW3 A78705H (P continuous = 12 kW)

VW3 A78706H (P continuous = 34 kW)

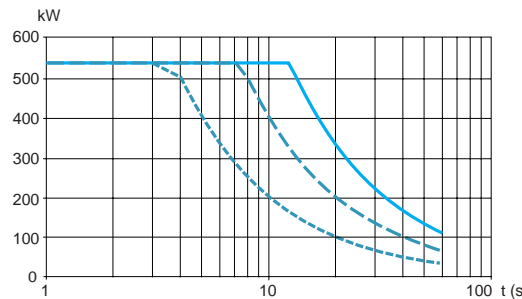
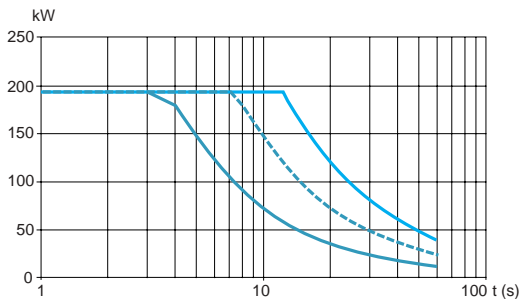

VW3 A78707H (P continuous = 50 kW)

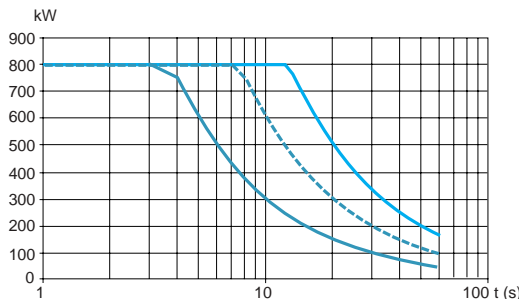

— P max (60 s cycle)  
 - - - P max (120 s cycle)  
 — P max (200 s cycle)

### Presentation

The Altivar 78 variable speed drive is designed to accept a total of 5 option cards, including fieldbus cards, into 5 slots labelled from A to E located on the control basket.

### Environmental characteristics

Ambient air temperature around the device	Operation	°C	- 10...+ 55
	Storage	°C	- 40...+ 60
Maximum relative humidity		%	< 95, no condensation allowed
Maximum operating altitude		m	1000
Vibration resistance			0,5 gn at 9...200 Hz

### Electrical characteristics

Analogue inputs AI	AIV		0...± 10 V, $R_i \geq 200 \text{ k}\Omega$ , single-ended Resolution 10 bits/0.1 %, accuracy $\pm 1 \%$ of the full display (- 10...+ 10 V joystick control)
	AIC		0 (4)...20 mA, $R_i = 250 \Omega$ , differential Resolution 10 bits/0.1 %, accuracy $\pm 1 \%$ of the full display
Analogue outputs AO	AOV		0 (2)...10 V, $R_L \geq 1 \text{ k}\Omega$ , resolution 10 bits, accuracy $\leq \pm 2 \%$
	AOC		0 (4)...20 mA, $R_L < 500 \Omega$ , resolution 10 bits/0.1 %, accuracy $\leq \pm 2 \%$
Digital inputs DI	DC		Control voltage $\approx 24 \text{ V}$ status 0 if < 5 V, status 1 if > 11 V
	AC		Control voltage $\sim 42...240 \text{ V}$ status 0 if < 33 V, status 1 if > 35 V
Auxiliary voltage	Output		$\approx 24 \text{ V}$ ( $\pm 15 \%$ ), max 250 mA (total summarized load from ext. $\approx 24 \text{ V}$ outputs, max. 150 mA from one card)
	Input		$\approx 24 \text{ V}$ ( $\pm 10 \%$ , max. ripple voltage 100 mV RMS), max. 1A In special applications where PLC type functions are included in the control unit, the input can be used as external auxiliary power supply for control cards as well as I/O extension cards
Output voltage			10 V 0...+ 2 %, max. 10 mA
Open collector output DO			10 mA, $\approx 48 \text{ V}$ maximum
Relay outputs RO			Switching capacity $\approx 24 \text{ V}/8 \text{ A}$ $\sim 1250 \text{ V}/8 \text{ A}$ $\approx 125 \text{ V}/0.4 \text{ A}$ Max. continuous load: 2 A rms Min. switching load: 5 V/10 mA
Thermistor input TI			$R_{\text{trip}} = 4.7 \text{ k}\Omega$ (PTC type)
Encoder control voltage			+ 5 V/+ 12 V/+ 15 V/+ 24 V (see schemes page 60634/2)
Encoder connections			Inputs, outputs (see schemes page 60634/2)

### References

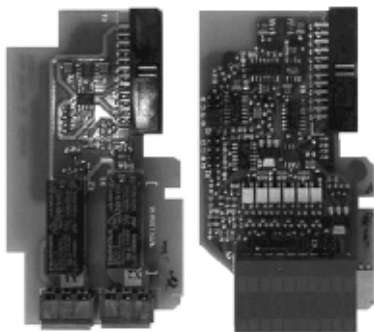

VW3 A7820●

Description	Slot number	Reference	Weight kg
6DI, 1DO, 2AI, 1AO, + 10, 24 V/EXT + 24 V	A	<b>VW3 A78201</b> (1)	0.200
2RO (NO/NC)	B	<b>VW3 A78202</b> (1)	0.200
1RO (NO/NC), 1RO (NO), 1 thermistor input	B	<b>VW3 A78203</b> (3)	0.200
3DI (Encoder RS 422), out + 5 V + 15 V	C	<b>VW3 A78204</b> (2) (3)	0.200
3DI (Encoder 10...24 V), out + 15 V + 24 V	C	<b>VW3 A78205</b> (2) (3)	0.200
6DI, 1DO, 2AI, 1AO, + 10, 24 V/EXT + 24 V, all I/O are galvanically isolated	A	<b>VW3 A78206</b> (3)	0.200
Duplicate encoder card with two encoder inputs (used as Master/Slave), + 15 V or + 24 V range	C	<b>VW3 A78207</b> (2) (3)	0.200
1 + 24 V/Ext + 24 V, 3 Pt 100	B, C, D, E	<b>VW3 A78208</b> (3)	0.200
1RO (NO), 5 digital inputs $\sim 42...240 \text{ V}$	B, C, D, E	<b>VW3 A78209</b> (3)	0.200
2 isolated AO, 1AI	B, C, D, E	<b>VW3 A78210</b>	0.200
3RO (NO)	B, C, D	<b>VW3 A78211</b>	0.200

- (1) The cards **VW3 A78201** and **A78202** are integrated in the Altivar 78 variable speed drive.  
(2) For Closed Loop Flux Vector Control applications, cards **VW3 A78204**, **A78205** and **A78207** must be used with the **ATV 78●F●●●●** variable speed drive (see page 60623/2).  
(3) The conformal coating is available by adding the suffix **S337** to the part number.  
Example: **VW3 A78201** becomes **VW3 A78201S337**.

# Variable speed drives for asynchronous motors

Altivar 78

Options: communication cards

## Presentation

The Altivar 78 variable speed drive can be adapted for communication by adding a communication card or module.

The models are available for the following buses: Modbus, DeviceNet, Profibus DP, LonWorks and CANopen.

### Functions common to all fieldbuses option cards:

- control (accessible in read and write): run/stop, speed reference, fault reset, etc.
- Monitoring (only accessible in read): drive status register, motor speed, motor current, logic I/O status register, fault, register, etc.
- Authorization of local control (via terminals).
- Configuration (accessible in read and write): all variable speed drive parameter registers
- Adjustment (accessible in read and write): ramp time, thermal protection, speed range, current limit, etc.

## Characteristics

Protocol	Modbus	DeviceNet	Profibus DP	LonWorks	N2	CANopen
Number of devices on network	31	64	127	64	32	127
Transmission speed	0.3...38.4 Kbps	125...500 Kbps	0.96...12 Mbps	78 Kbaud	9.6 Kbps	0.01...1 Mbps
Data transfer method	RS 485 half duplex	RS 485 CANopen	RS 485 half duplex	Twisted pair	Twisted pair	CANopen (ISO 11898)

## References



VW3 A78307

Description	Slot number	Reference (1)	Weight kg
<b>Modbus:</b> connected to fieldbus through a 5-pin plug-in bus connector. (possible N2)	D, E	<b>VW3 A78306</b>	0.300
<b>Profibus DP:</b> connected to fieldbus through a 5-pin plug-in bus connector	D, E	<b>VW3 A78307</b>	0.300
<b>CANopen slave:</b> connected to fieldbus through a 5-pin plug-in bus connector	D, E	<b>VW3 A78308</b>	0.300
<b>DeviceNet:</b> connected to fieldbus through a 5-pin plug-in bus connector	D, E	<b>VW3 A78309</b>	0.300
<b>LonWorks:</b> connected to fieldbus through a 3-pin plug-in bus connector	D, E	<b>VW3 A78312</b>	0.300

(1) The conformal coating is available by adding the suffix **S337** to the part number.  
Exemple: **VW3 A78306** becomes **VW3 A78306S337**

# Variable speed drives for asynchronous motors

## Altivar 78 Accessories

DF663076



VW3 A7810●

### Programming terminal remote mounting kit

The Altivar 78 is supplied with a detachable programming terminal (see page 60635/2).

A terminal support option allows remote mounting of the programming terminal at a distance of 2 or 15 metres. It is particularly suitable for mounting on the enclosure door.

The programming terminal remote mounting kit includes:

- terminal support,
- connection cable (2 or 15 m lengths),
- screws and washers.

Description	Cable length m	For drives	Reference	Weight kg
Terminal support	2	ATV 78 all ratings	VW3 A78102	1.000
	15	ATV 78 all ratings	VW3 A78103	1.000

### PC-based setup software ATV 78 Soft

The PC software is provided in a CD-ROM, shipped with the product.

The PC connection kit allows the connection between the PC operating in a Microsoft Windows® environment.

Minimum PC configuration: Pentium 3 processor with 128 Mb of RAM.  
Operating system: Windows® 95, 98, NT, 2000 or XP.

Main functions:

- drive configuration,
- configuration backup,
- print out of complete parameter list,
- parameters comparison,
- load a configuration from one drive to another,
- oscilloscope mode for maintenance,
- control and monitoring.

Description	Cable length m	For drives	Reference	Weight kg
PC cable	1.5	ATV 78 all ratings	VW3 A78332	0.300

### IP 54 kit (NEMA type 12)

The IP 54 kit enhances the enclosure IP 21 protection class of the variable speed drive to IP 54 protection class. The IP 54 enclosure provides protection against dust and water sprayed from all directions. However, it does not protect the variable speed drive against strong jets of water or if it is immersed.

The IP 54 kit includes:

- IP 54 enclosure,
- IP 54 lid with fan,
- cable entry flange with rubber grommets,
- rubber sealings,
- screws, cable anchors, fastening straps, warning sticker.

Description	For drives	Reference	Weight kg
IP 54 kit	ATV 782U22Y...2D22Y	VW3 A78801	1.500
	ATV 782FU22Y...2FD22Y		

# Variable speed drives for asynchronous motors

## Altivar 78 Accessories

### Flange mounting kit

To reduce power dissipated in the enclosure, the Altivar 78 variable speed drive IP 20/NEMA type 1 from 2.2 to 160 kW (2 to 150 HP) may be flange mounted in a wall of the enclosure with the heatsink on the outside. This requires a cutout in the enclosure and a flange mounting kit.

For flange mounting, the heatsink and fan on the outside of the enclosure are IP 54/NEMA type 12 degree of protection.

The flange mounting kit includes:

- gaskets,
- top and bottom flange,
- fan,
- sealing tape,
- cable tie, screws,
- instructions and cutout dimensions.

For drives	Reference	Weight kg
ATV 782U22Y...2D22Y ATV 782FU22Y...2FD22Y	<b>VW3 A78806</b>	0.370
ATV 782D30Y and 2D37Y ATV 782FD30Y and 2FD37Y	<b>VW3 A78807</b>	2.000
ATV 782D45Y...2D75Y ATV 782FD45Y...2FD75Y	<b>VW3 A78808</b>	3.000
ATV 782D90Y...2C16Y ATV 782FD90Y...2FC16Y	<b>VW3 A78809</b>	8.500

### Demo case

The demo case can be used for demonstration purposes at a tradeshow, customer meeting, or product presentation. It has a  $\sim$  115/230 V dual voltage input rating.

The Altivar 78 demo case includes:

- ABS case,
- Altivar 78 variable speed drive with keypad display,
- power cord and PC connection cable,
- PC software,
- switches, LED's and analog meter.

Description	Reference	Weight kg
Altivar 78 demo case	<b>VW3 A78DEMO</b>	12.700

DF564077



VW3 A78DEMO

# Variable speed drives for asynchronous motors

Altivar 78  
Variable speed drives

## Variable speed drives

ATV 78●U22Y to ●C16Y and ATV 78●FU22Y to ●FC16Y (the line choke is integrated)

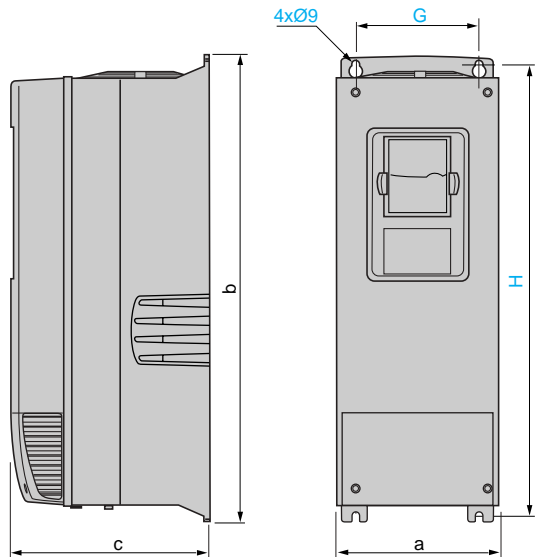

ATV 78●, ATV 78●F	a	b	c	G	H
U22Y...D22Y	195	558	237	148	541
D30Y...D37Y	237	630	257	190	614
D45Y...D75Y	289	755	344	255	732
D90Y...C16Y	480	1150	362	400	1120

ATV 780C20Y to 0C31Y and ATV 780FC20Y to 0FC31Y (the line choke is supplied with the variable speed drive but not integrated)

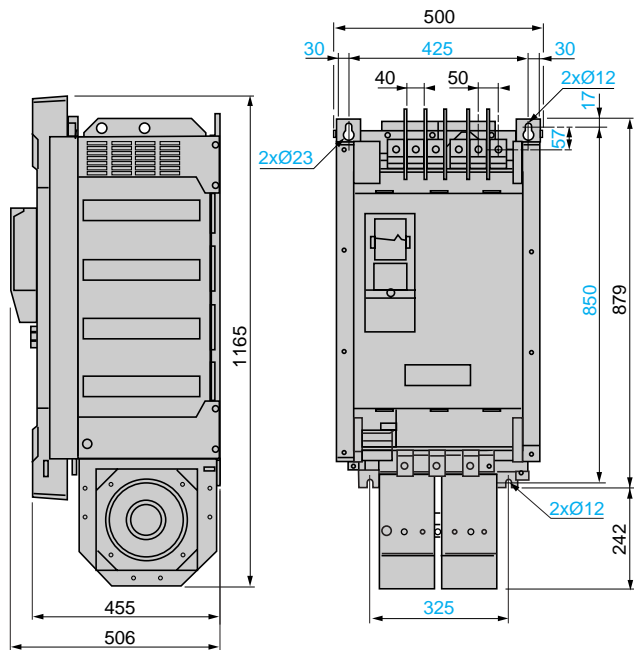

## Line choke

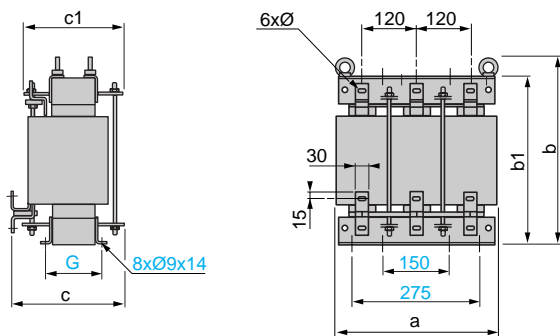

For drives ATV 78	a	b	b1	c	c1	G	Ø
0C20Y, 0FC20Y	354	357	319	230	206	108	9x14
0C25Y...0C31Y 0FC25Y...0FC31Y	350	421	383	262	238	140	11x15



# Variable speed drives for asynchronous motors

Altivar 78

Variable speed drives

## Variable speed drives (continued)

ATV 780C35Y to 0C50Y and ATV 780FC35Y to 0FC50Y (the line choke is supplied with the variable speed drive but not integrated)

Without terminal cover

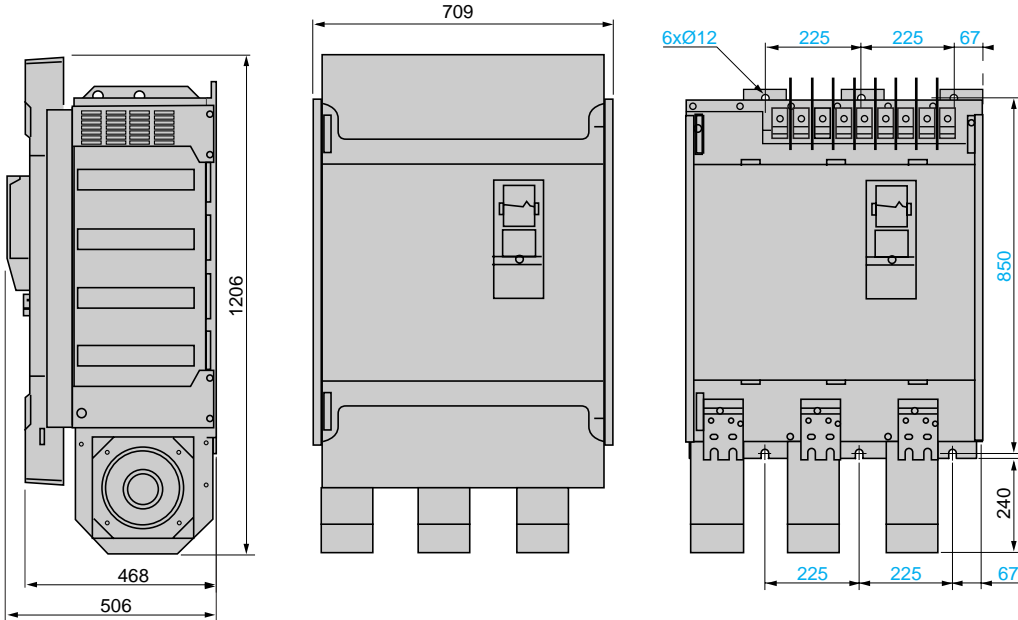

### Line choke for variable speed drives ATV 780C35Y, 0C45Y and ATV 780FC35Y, 0FC45Y

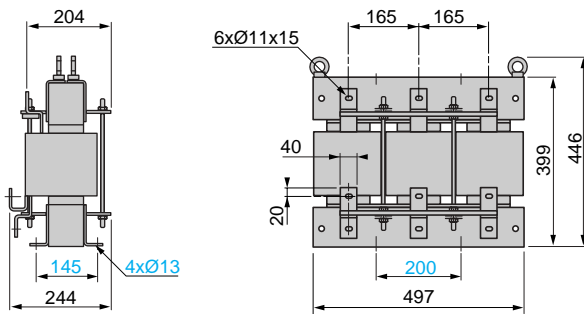

### Line choke for variable speed drives ATV 780C50Y and ATV 780FC50Y (1)

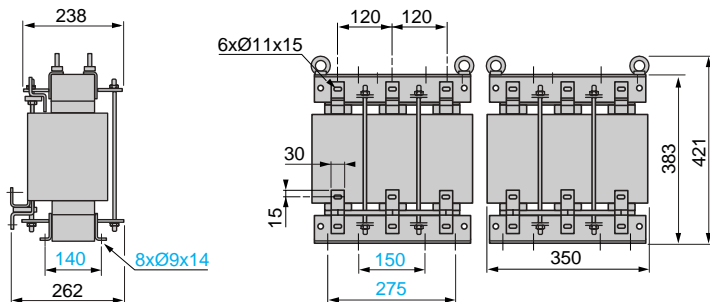

(1) Two line chokes supplied.

# Variable speed drives for asynchronous motors

Altivar 78

Variable speed drives, programming terminal mounting kit

## Variable speed drives (continued)

ATV 780C56Y to ●C71Y and ATV 780FC56Y to ●FC71Y (the line choke is supplied with the variable speed drive but not integrated) (1)

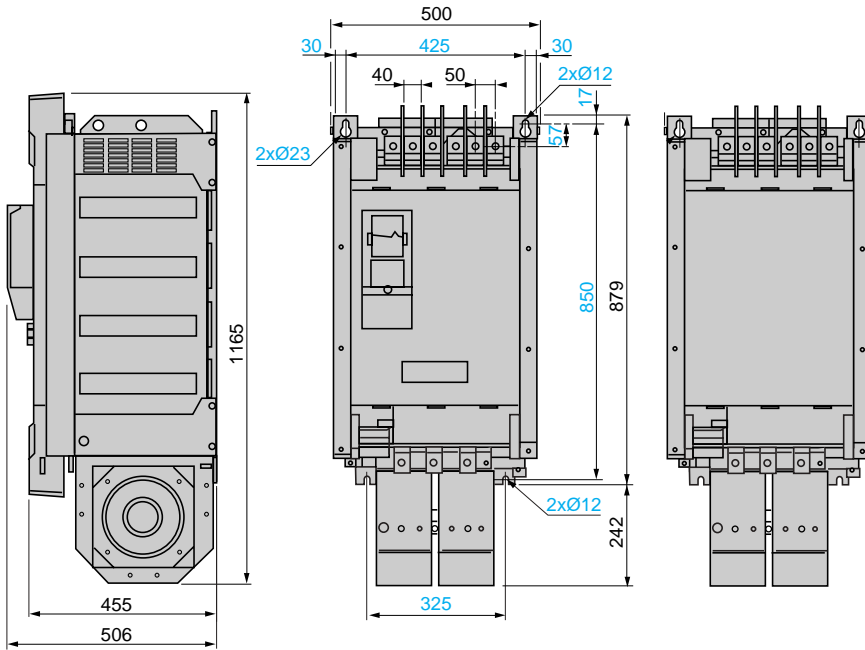

(1) Two power units and one control unit supplied.

## Line choke (1)

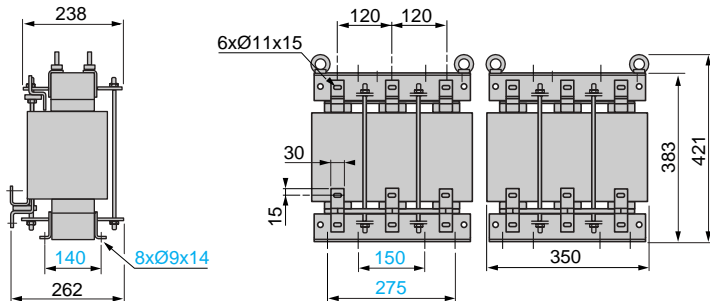

(1) Two line chokes supplied

## Programming terminal remote mounting kit

VW3 A78102 and VW3 A78103

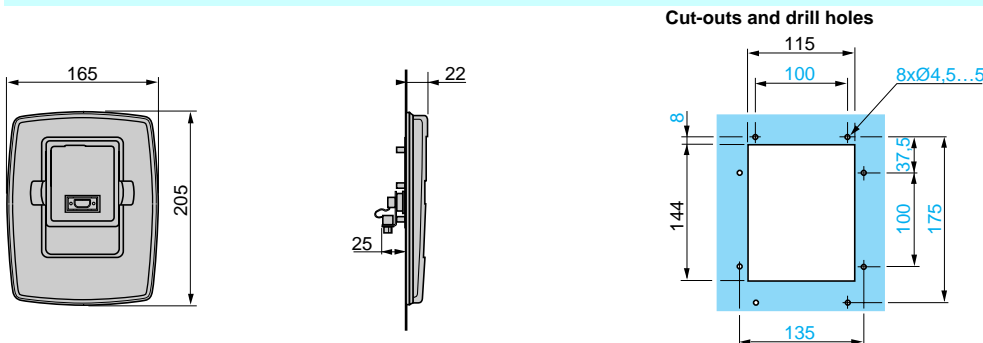

# Variable speed drives for asynchronous motors

Altivar 78  
dv/dt long lead filters

## dv/dt long lead filters

### VW3 A78601C to VW3 A78603C

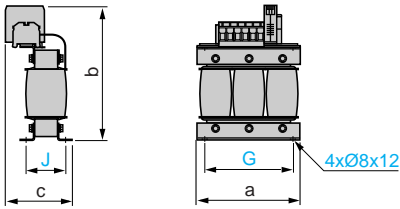

VW3	a	b	c	G	J
A78601C	155	220	130	130	72
A78602C	190	250	130	170	78
A78603C	210	280	135	180	81

### VW3 A78604C and VW3 A78605C

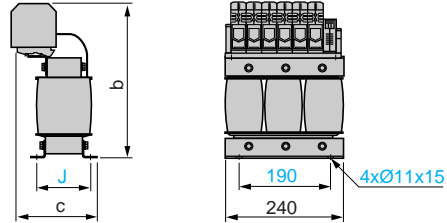

VW3	b	c	J
A78604C	300	160	105
A78605C	320	185	125

### VW3 A78606C to VW3 A78608C

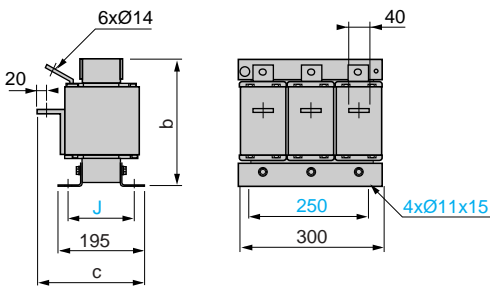

VW3	b	c	J
A78606C	270	235	125
A78607C	270	250	150
A78608C	330	250	150

### VW3 A78609C

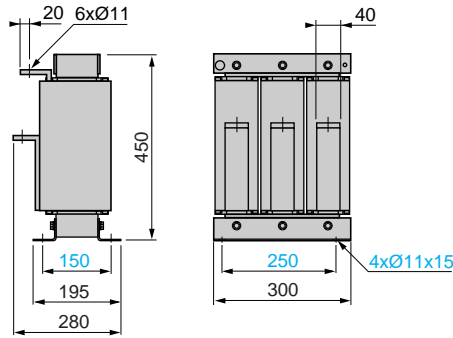

### VW3 A78610C

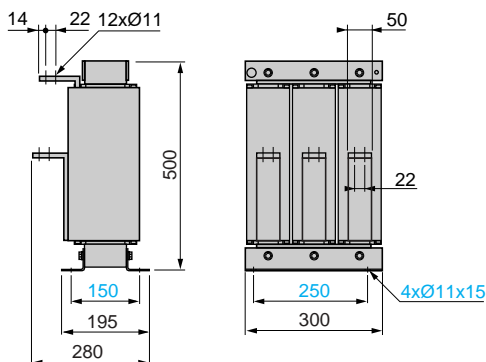

# Variable speed drives for asynchronous motors

Altivar 78  
Braking resistors

## Braking resistors: braking time 5 s

### VW3 A78701L

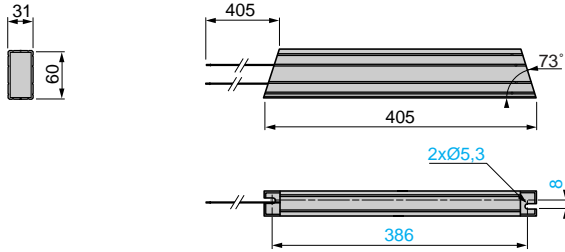

#### Mounting recommendations (1)

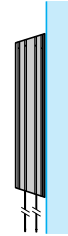

(1) When vertical mounted, the cables must be located at the bottom.

### VW3 A78702L and VW3 A78703L

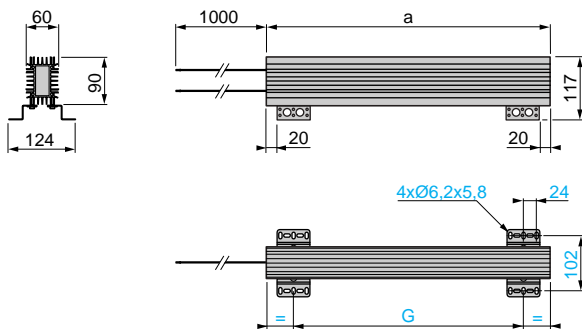

#### Mounting recommendations (1)

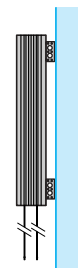

(1) When vertical mounted, the cables must be located at the bottom.

VW3	a	G
A78702L	426	326
A78703L	725	626

### VW3 A78704L

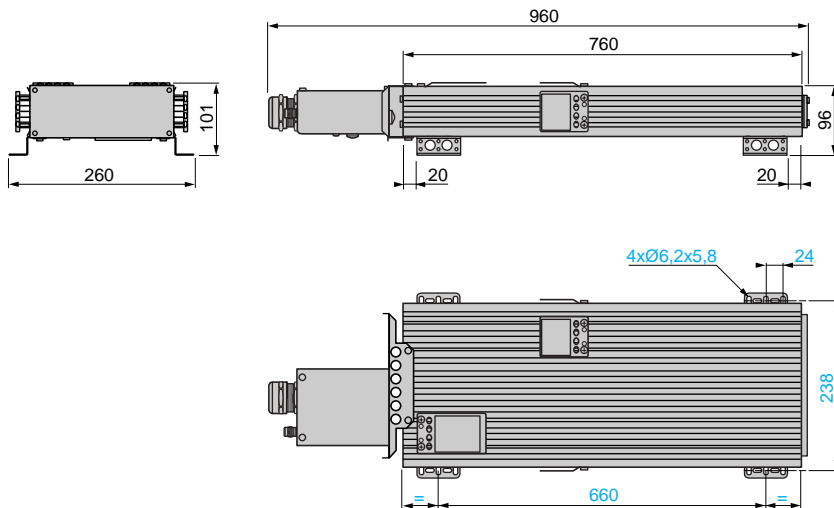

#### Mounting recommendations (1)

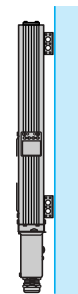

(1) When vertical mounted, the cables must be located at the bottom.

# Variable speed drives for asynchronous motors

Altivar 78  
Braking resistors

## Braking resistors: braking time 5 s (continued)

VW3 A78705L

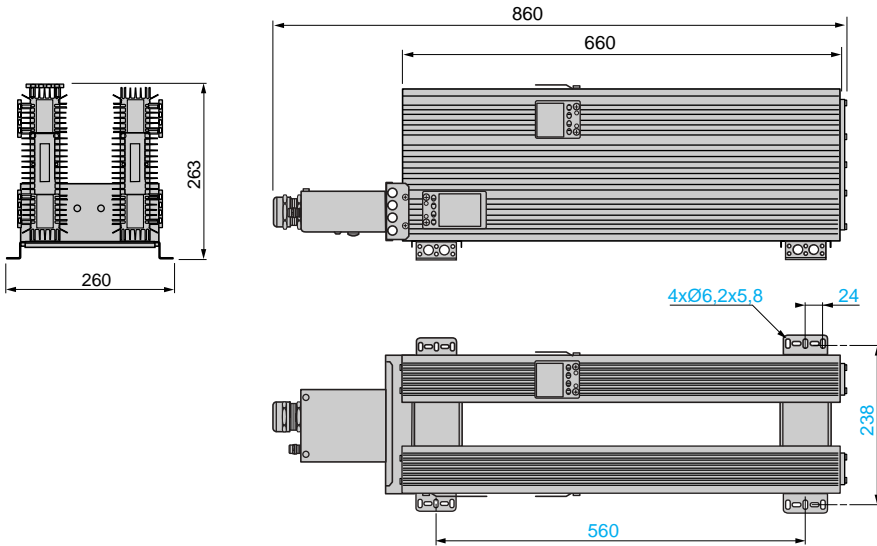

### Mounting recommendations (1)

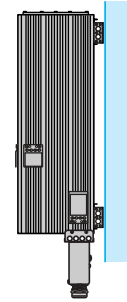

(1) When vertical mounted, the cables must be located at the bottom.

## VW3 A78706L and VW3 A78707L

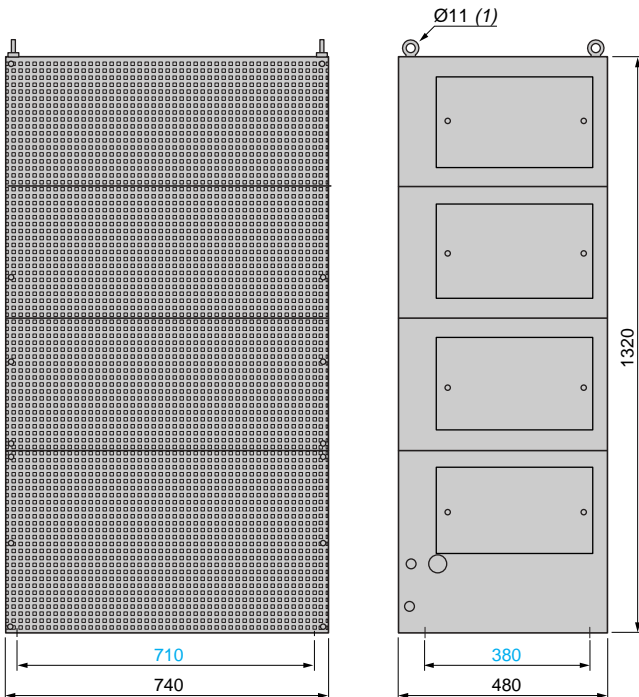

(1) Lifting eye bolt.

# Variable speed drives for asynchronous motors

## Altivar 78

### Braking resistors

#### Braking resistors: braking time 10 s

##### VW3 A78701H

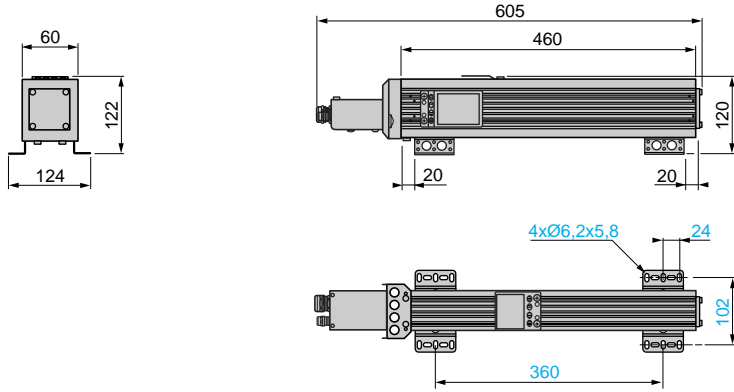

#### Mounting recommendations (1)

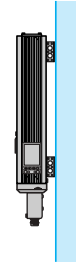

(1) When vertical mounted, the cables must be located at the bottom.

##### VW3 A78702H

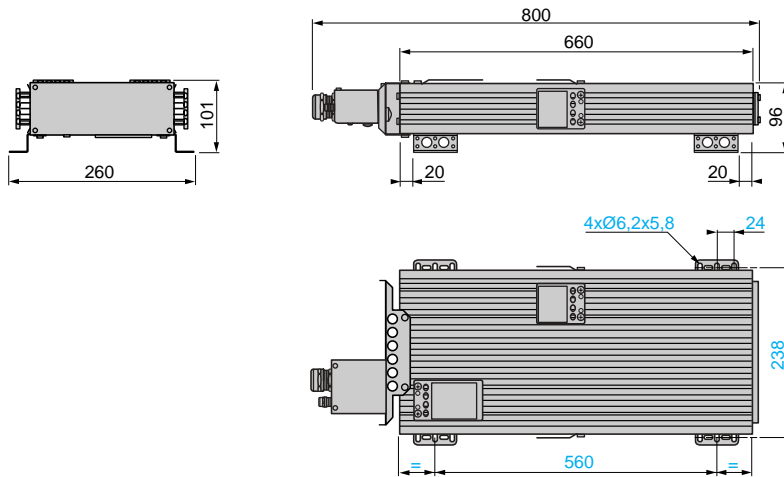

#### Mounting recommendations (1)



(1) When vertical mounted, the cables must be located at the bottom.

##### VW3 A78703H

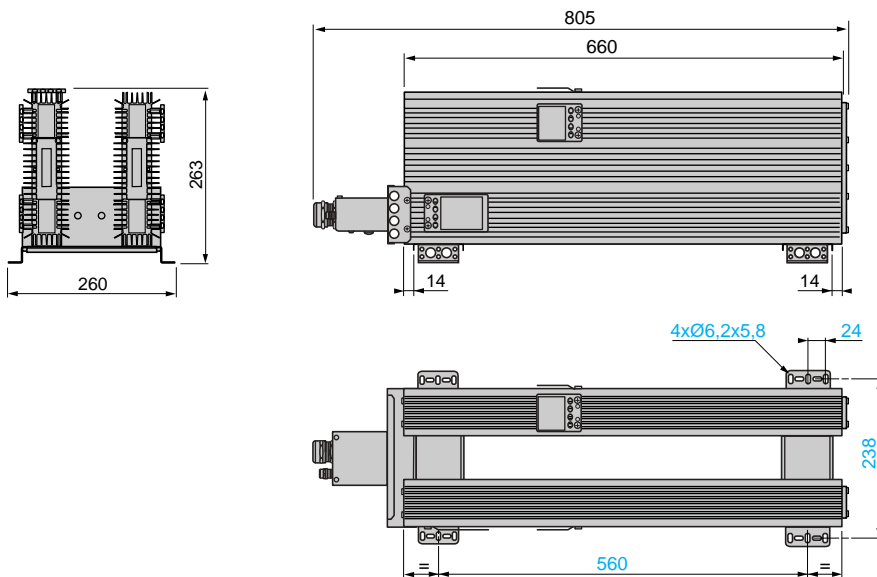

#### Mounting recommendations (1)

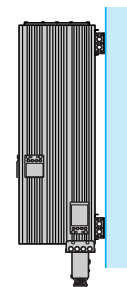

(1) When vertical mounted, the cables must be located at the bottom.

**Braking resistors: braking time 10 s (continued)**

VW3 A78704H, VW3 A78705H

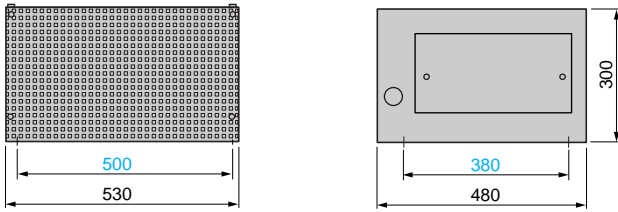

VW3 A78706H

VW3 A78707H

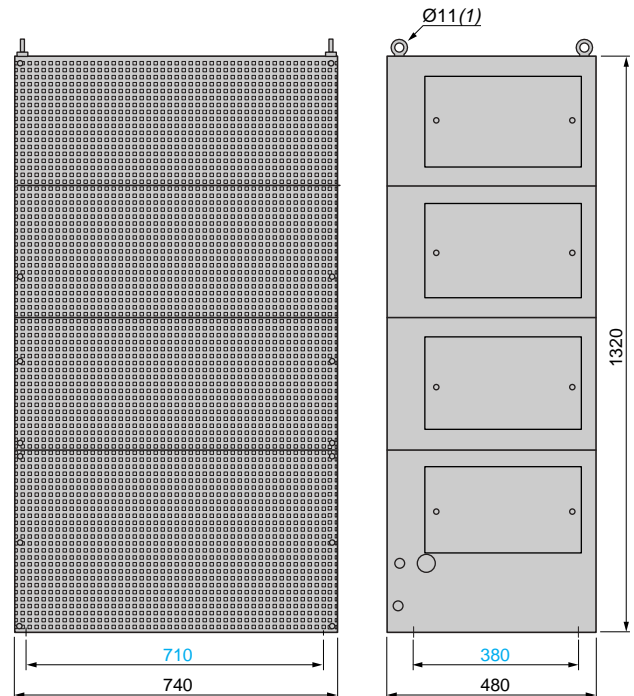
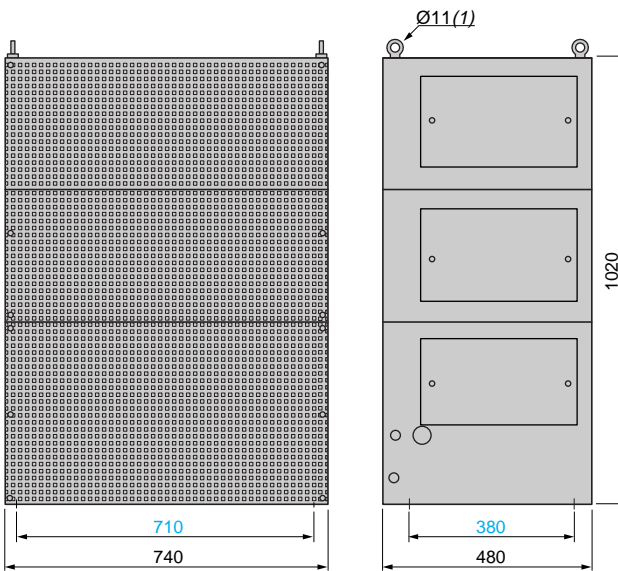

(1) Lifting eye bolt.

(1) Lifting eye bolt.

**Braking resistor connection kit for ATV 78●D45Y to ●C16Y**

VW3 A78810

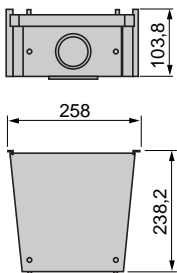

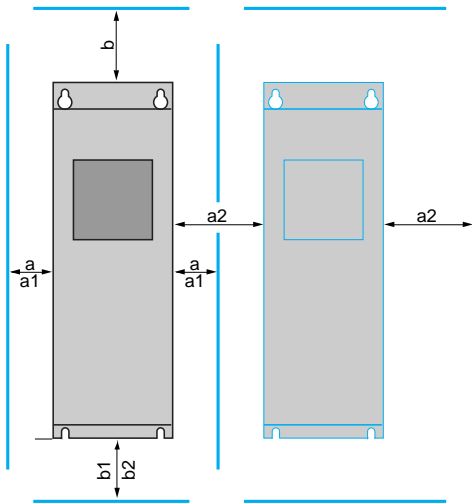

Mounting recommendations

### Mounting recommendations for ATV 78●U22Y to ●C16Y and ATV 78●FU22Y to ●FC16Y variable speed drives

- Observe the minimum clearance space shown opposite when installing
- Install the Altivar 78 in a vertical position
- Make provision for evacuation of the hot air to the outside of the enclosure
- Make provision for an air inlet on the door of the enclosure
- Pay attention to ambient temperature (see characteristics, page 60621/2).

If several units are mounted above each other, the minimum required clearance space equals  $b + b1$  ( $b + b2$ ), see figure.

Avoid harmful environments such as those with high temperature and humidity levels as well as environments containing dust, dirt or corrosive gases. The location must be well ventilated and away from direct sunlight.

For variable speed drives	a mm	a1 mm	a2 mm	b mm	b1 mm	b2 mm
ATV 78●U22Y...●D22Y ATV 78●FU22Y...●FD22Y	30	–	20	160	80	–
ATV 78●D30Y and ●D37Y ATV 78●FD30Y and ●FD37Y	80	–	80	300	100	–
ATV 78●D45Y...●D75Y ATV 78●FD45Y...●FD75Y	80	150	80	300	200	–
ATV 78●D90Y...●C16Y ATV 78●FD90Y...●FC16Y	50	–	80	400	250	350

a: clearance around the variable speed drive (see also a1 and a2).

a1: clearance needed on either side of the variable speed drive for changing fan(s) (without disconnecting the motor cables).

a2: distance from one variable speed drive to another or distance to enclosure wall

b: free space above the variable speed drive.

b1: free space underneath the variable speed drive.

b2: clearance needed underneath the variable speed drive for changing fan(s).

### Fan flow rate depending on the drive rating

For variable speed drives	Flow rate m <sup>3</sup> /h
ATV 78●U22Y...●D22Y ATV 78●FU22Y...●FD22Y	425
ATV 78●D30Y and ●D37Y ATV 78●FD30Y and ●FD37Y	425
ATV 78●D45Y...●D75Y ATV 78●FD45Y...●FD75Y	650
ATV 78●D90Y...●C16Y ATV 78●FD90Y...●FC16Y	1300



### Mounting recommendations for ATV 780C20Y to 0C71Y and ATV 780FC20Y to 0FC71Y variable speed drives

The Altivar 78 has an IP 00 rating (open type) and it will be supplied with a separate line choke, a control unit with fixing plate and connection cables.

#### Installing the line choke

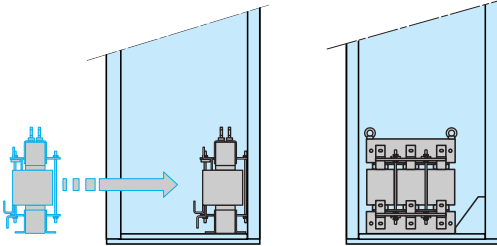

The recommended location for the line choke is the bottom left of the enclosure, close to the rear panel. Fasten the line choke on an assembly plate or using mounting rails.

**Note:** in units with two parallel chokes (from ATV 780(F)C50Y to ATV 780(F)C71Y), both chokes have to be wired in the same way. If chokes are wired differently, the variable speed drive may be damaged.

#### Preparing and mounting the Altivar 78

It is recommended that the Altivar 78 be mounted on rails to facilitate possible future service work.

Fasten mounting rails to the sides of the enclosures at a distance at least 910 mm from the top of the enclosure.

Leave a space of at least 50 mm between the rails and one side of panel for the internal cooling air circulation. Note that the two enclosures, in which the ATV 780(F)C56Y to ATV 780(F)C71Y variable speed drives are installed, require no clearance between them.

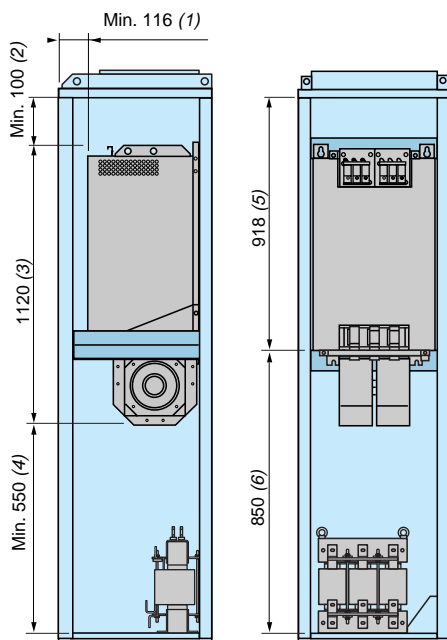

- (1) Minimum distance from the enclosure door; this is to enable the control unit to be installed in front of the power module.
- (2) Minimum distance from the top of the enclosure; this space is needed for the power cables.
- (3) Drive height.
- (4) Minimum distance from the bottom of the enclosure if the line choke is installed at the bottom of the enclosure. If the line choke is installed in another location, the distance must not, however, be smaller than 290 mm. Clearance needed underneath the variable speed drive for changing fan(s) must not be less than 70 mm.
- (5) Minimum distance from the mounting rails to top of the enclosure.
- (6) Minimum distance from the mounting rails to the bottom of the enclosure. If the choke is installed in another location, the distance must not, however, be smaller than 590 mm.

**Table showing possible combinations of Altivar 78 variable speed drive options**

Motor	Altivar 78 variable speed drive for high or standard applications	Options (1)			
		dv/dt filter	Braking resistor - cycle times: 60/120/200 s (2)		Braking resistor connection kit
			Braking time 5 s	Braking time 10 s	
3-phase supply voltage: 525...690 V 50/60 Hz	ATV 78U22Y, OFU22Y	VW3 A78601C	VW3 A78701L	VW3 A78701H	–
	ATV 78U30Y, OFU30Y	VW3 A78601C	VW3 A78701L	VW3 A78701H	–
	ATV 78U40Y, OFU40Y	VW3 A78601C	VW3 A78701L	VW3 A78701H	–
	ATV 78U55Y, OFU55Y	VW3 A78601C	VW3 A78701L	VW3 A78701H	–
	ATV 78U75Y, OFU75Y	VW3 A78601C	VW3 A78701L	VW3 A78701H	–
	ATV 78D11Y, OFD11Y	VW3 A78601C	VW3 A78702L	VW3 A78702H	–
	ATV 78D15Y, OFD15Y	VW3 A78601C	VW3 A78702L	VW3 A78702H	–
	ATV 78D18Y, OFD18Y	VW3 A78602C	VW3 A78702L	VW3 A78702H	–
	ATV 78D22Y, OFD22Y	VW3 A78602C	VW3 A78702L	VW3 A78702H	–
	ATV 78D30Y, OFD30Y	VW3 A78602C	VW3 A78703L	VW3 A78703H	–
	ATV 78D37Y, OFD37Y	VW3 A78602C	VW3 A78703L	VW3 A78703H	–
	ATV 78D45Y, OFD45Y	VW3 A78603C	VW3 A78704L	VW3 A78704H	VW3 A78810
	ATV 78D55Y, OFD55Y	VW3 A78603C	VW3 A78704L	VW3 A78704H	VW3 A78810
	ATV 78D75Y, OFD75Y	VW3 A78604C	VW3 A78704L	VW3 A78704H	VW3 A78810
	ATV 78D90Y, OFD90Y	VW3 A78604C	VW3 A78705L	VW3 A78705H	VW3 A78810
	ATV 78C11Y, OFC11Y	VW3 A78605C	VW3 A78705L	VW3 A78705H	VW3 A78810
	ATV 78C13Y, OFC13Y	VW3 A78605C	VW3 A78705L	VW3 A78705H	VW3 A78810
	ATV 78C16Y, OFC16Y	VW3 A78605C	VW3 A78705L	VW3 A78705H	VW3 A78810
	ATV 78C20Y, OFC20Y	VW3 A78606C	VW3 A78706L	VW3 A78706H	–
	ATV 78C25Y, OFC25Y	VW3 A78607C	VW3 A78706L	VW3 A78706H	–
	ATV 78C31Y, OFC31Y	VW3 A78608C	VW3 A78706L	VW3 A78706H	–
	ATV 78C35Y, OFC35Y	VW3 A78609C	VW3 A78707L	VW3 A78707H	–
	ATV 78C45Y, OFC45Y	VW3 A78609C	VW3 A78707L	VW3 A78707H	–
	ATV 78C50Y, OFC50Y	VW3 A78609C	VW3 A78707L	VW3 A78707H	–
	ATV 78C56Y, OFC56Y	VW3 A78610C	2 x VW3 A78706L	2 x VW3 A78706H	–
	ATV 78C63Y, OFC63Y	VW3 A78610C	2 x VW3 A78706L	2 x VW3 A78706H	–
	ATV 78C71Y, OFC71Y	VW3 A78610C	2 x VW3 A78706L	2 x VW3 A78706H	–
<b>Pages</b>	60623/2 and 60628/3	60625/2	60626/3	60626/3	

(1) The line chokes are supplied with the Altivar 78 variable speed drives (see pages 60624/2 and 60624/3).

(2) For special applications such as hoisting, please refer to the curves (see pages 60627/2 and 60627/3).



**3-phase supply voltage: 525 to 690 V** (for motors 2.2 to 710 kW or 2 to 800 HP)

Input current rating		Circuit breaker	Line contactor	Variable speed drive
High torque (150 % Tn)	Standard torque (110 % Tn)	Reference (1)	Reference (2) (3)	Reference (4)
A	A			
3	4.5	GV2 P10	LC1 D09	ATV 78●U22Y, ●FU22Y
4	5.5	GV2 P10	LC1 D09	ATV 78●U30Y, ●FU30Y
5	7.5	GV2 P14	LC1 D09	ATV 78●U40Y, ●FU40Y
7	10	GV2 P14	LC1 D09	ATV 78●U55Y, ●FU55Y
10	13	GV2 P16	LC1 D09	ATV 78●U75Y, ●FU75Y
13	18	GV2 P21	LC1 D09	ATV 78●D11Y, ●FD11Y
18	22	GV2 P22	LC1 D09	ATV 78●D15Y, ●FD15Y
22	27	NS80HMA50	LC1 D18	ATV 78●D18Y, ●FD18Y
27	34	NS80HMA50	LC1 D25	ATV 78●D22Y, ●FD22Y
34	41	NS80HMA50	LC1 D32	ATV 78●D30Y, ●FD30Y
41	52	NS80HMA65	LC1 D40	ATV 78●D37Y, ●FD37Y
52	62	NS80HMA65	LC1 D65	ATV 78●D45Y, ●FD45Y
62	80	NS100●MA100	LC1 D80	ATV 78●D55Y, ●FD55Y
80	100	NS160●MA150	LC1 D80	ATV 78●D75Y, ●FD75Y
100	125	NS160●MA150	LC1 D80	ATV 78●D90Y, ●FD90Y
125	144	NS160●MA150	LC1 F115	ATV 78●C11Y, ●FC11Y
144	170	NS250●MA220	LC1 F115	ATV 78●C13Y, ●FC13Y
170	208	NS250●MA220	LC1 F185	ATV 78●C16Y, ●FC16Y
208	261	NS400●STR43ME	LC1 F265	ATV 780C20Y, 0FC20Y
261	325	NS400●STR43ME	LC1 F330	ATV 780C25Y, 0FC25Y
325	385	NS400●STR43ME	LC1 F400	ATV 780C31Y, 0FC31Y
385	460	NS630●STR43ME	LC1 F630	ATV 780C35Y, 0FC35Y
460	502	NS630●STR43ME	LC1 F630	ATV 780C45Y, 0FC45Y
502	590	NS630●STR43ME	LC1 F630	ATV 780C50Y, 0FC50Y
590	650	NS800 Micrologic 2.0	LC1 F800	ATV 780C56Y, 0FC56Y
650	750	NS800 Micrologic 2.0	LC1 F800	ATV 780C63Y, 0FC63Y
750	820	NS800 Micrologic 2.0	LC1 BM	ATV 780C71Y, 0FC71Y

(1) NS●●●: product sold under Merlin Gerin brand. Please consult your Regional Sales Office.

(2) Contactor reference must be completed by the code corresponding to 690 V coil voltage. Please consult your Regional Sales Office.

(3) Composition of contactors:

LC1 D09 to LC1 D80: 3-pole + 1 "N/O" auxiliary contact + 1 "N/C" auxiliary contact

LC1 F115 to LC1 F630: 3-pole + 1 "N/O" holding circuit contact.

(4) In the reference, replace the ● with 2 for a drive IP 21 (NEMA type 1) or 5 for a drive IP 54 (NEMA type 12).

# Variable speed drives for asynchronous motors

Altivar 78  
Motor starters

## 3-phase supply voltage: 525 to 690 V (for motors 2.2 to 710 kW or 2 to 800 HP)

Input current rating		AC fuse				Line contactor	Variable speed drive
High torque (150 % Tn)	Standard torque (110 % Tn)	North America (600 V)		Europe (690 V)		Reference (1) (2)	Reference (3)
A	A	Fast acting	Fuse class	Fast acting	Fuse class		
3	4.5	10	J	10	gG/gL	LC1 D09	ATV 78●U22Y, ●FU22Y
4	5.5	10	J	10	gG/gL	LC1 D09	ATV 78●U30Y, ●FU30Y
5	7.5	10	J	10	gG/gL	LC1 D09	ATV 78●U40Y, ●FU40Y
7	10	15	J	16	gG/gL	LC1 D09	ATV 78●U55Y, ●FU55Y
10	13	15	J	16	gG/gL	LC1 D09	ATV 78●U75Y, ●FU75Y
13	18	20	J	20	gG/gL	LC1 D09	ATV 78●D11Y, ●FD11Y
18	22	25	J	25	gG/gL	LC1 D09	ATV 78●D15Y, ●FD15Y
22	27	35	J	35	gG/gL	LC1 D18	ATV 78●D18Y, ●FD18Y
27	34	40	J	35	gG/gL	LC1 D25	ATV 78●D22Y, ●FD22Y
34	41	50	J	50	gG/gL	LC1 D32	ATV 78●D30Y, ●FD30Y
41	52	60	J	63	gG/gL	LC1 D40	ATV 78●D37Y, ●FD37Y
52	62	80	J	80	gG/gL	LC1 D65	ATV 78●D45Y, ●FD45Y
62	80	100	J	80	gG/gL	LC1 D80	ATV 78●D55Y, ●FD55Y
80	100	125	J	100	gG/gL	LC1 D80	ATV 78●D75Y, ●FD75Y
100	125	150	J	160	gG/gL	LC1 D80	ATV 78●D90Y, ●FD90Y
125	144	175	J	160	gG/gL	LC1 F115	ATV 78●C11Y, ●FC11Y
144	170	200	J	170	gG/gL	LC1 F115	ATV 78●C13Y, ●FC13Y
170	208	250	J	250	gG/gL	LC1 F185	ATV 78●C16Y, ●FC16Y
208	261	400	J	700	aR	LC1 F265	ATV 780C20Y, 0FC20Y
261	325	500	J	700	aR	LC1 F330	ATV 780C25Y, 0FC25Y
325	385	600	J	700	aR	LC1 F400	ATV 780C31Y, 0FC31Y
385	460	700	J	1100	aR	LC1 F630	ATV 780C35Y, 0FC35Y
460	502	800	L	1250	aR	LC1 F630	ATV 780C45Y, 0FC45Y
502	590	900	L	700	aR	LC1 F630	ATV 780C50Y, 0FC50Y
590	650	1000	L	700	aR	LC1 F800	ATV 780C56Y, 0FC56Y
650	750	1200	L	700	aR	LC1 F800	ATV 780C63Y, 0FC63Y
750	820	1200	L	700	aR	LC1 BM	ATV 780C71Y, 0FC71Y

(1) Contactor reference must be completed by the code corresponding to 690 V coil voltage. Please consult your Regional Sales Office.

(2) Composition of contactors:

LC1 D09 to LC1 D80: 3-pole + 1 "N/O" auxiliary contact + 1 "N/C" auxiliary contact

LC1 F115 to LC1 F630: 3-pole + 1 "N/O" holding circuit contact

(3) In the reference, replace the ● with 2 for a drive IP 21 (NEMA type 1) or 5 for a drive IP 54 (NEMA type 12).

# Variable speed drives for asynchronous motors

## Altivar 78

**Wiring diagram for ATV 78●U22Y to ATV 780C71Y or ATV 78●FU22Y to ATV 780FC71Y (supply voltage 525 to 690 V)**

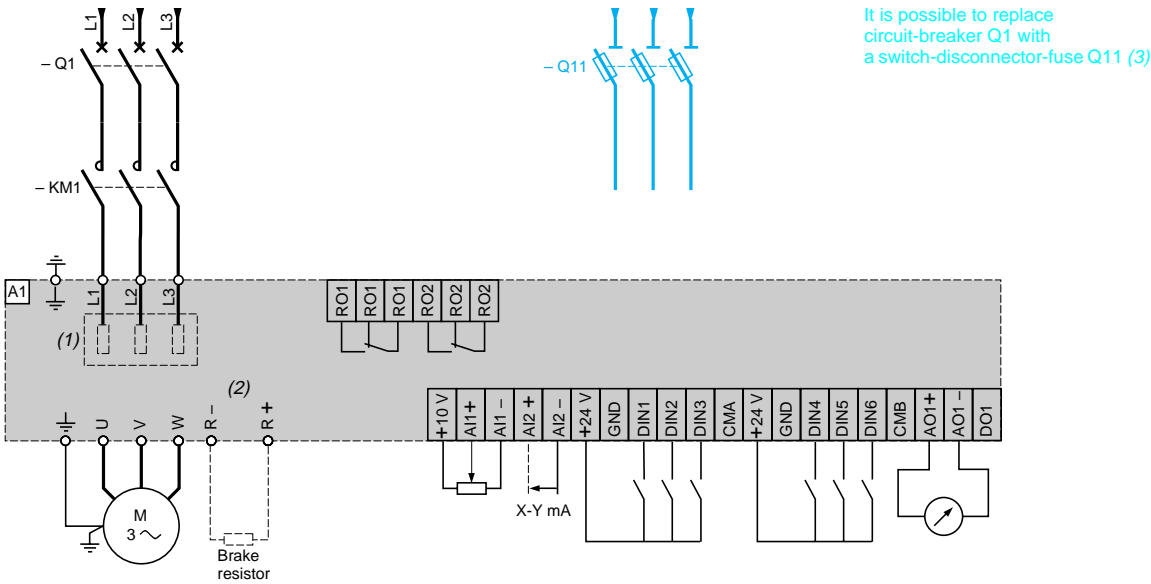

- (1) The line choke is integrated from **ATV 78●U22Y to ●C16Y** or **ATV 78●FU22Y to ●FC16Y**. From **ATV 780C20Y** and up, the line choke is supplied with the variable speed drive but not mounted inside the product.
- (2) Dynamic braking resistor should be added, if required, to variable speed drives **ATV 78●U22Y to ●C71Y** or **ATV 78●FU22Y to ●FC71Y**. If the braking resistor is equipped with a temperature controlled switch, wire this switch to a logic input (example: **DIN6**) and assign this logic input for "External Fault" (refer to the Programming Guide for more information).
- (3) See table on page 60633/3.

**Note:** for cabling the I/O extension cards (**VW3 A78201 to VW3 A78211**), please refer the I/O option manual.

### Examples of recommended schemes

#### Connection of logic inputs

**With internal + 24 V power supply**

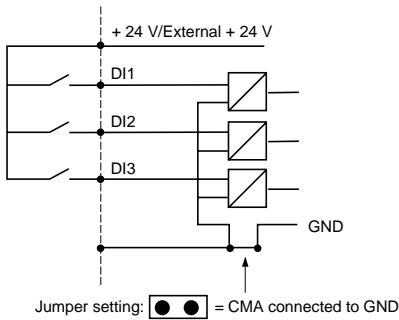

**With external + 24 V power supply and CMA isolated from GND using onboard jumper**

#### Positive logic

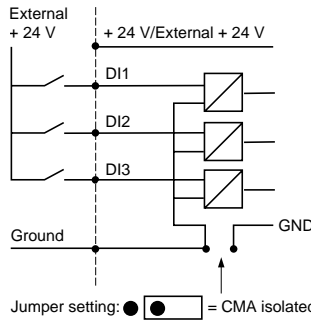

#### Negative logic

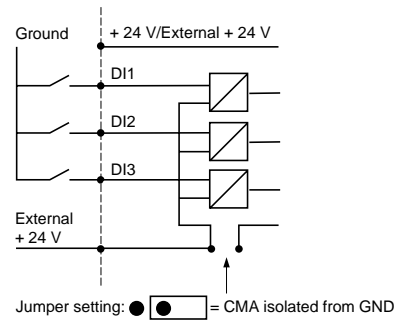

### Examples of recommended schemes (continued)

#### Connection of encoders

##### Differential connection of TTL type encoder with internal or external + 5 V power supply

+ 5 V/+ 15 V/+ 24 V from the VW3 A78204 extension card or from external supply (1)

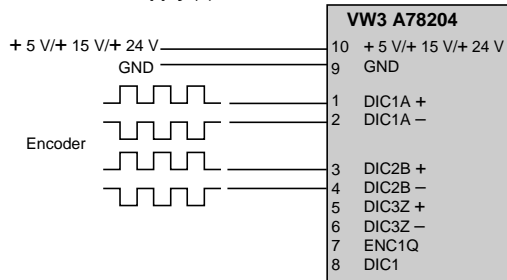

(1) If external supply is used, remember to connect the ground of external supply to terminal #9 of the VW3 A78204 and to the encoder ground.

##### Single ended connection of high voltage transistor logic (HTL) type encoder (open source) with internal or external + 24 V power supply

+ 15 V/+ 24 V from the VW3 A78205 extension card or from external supply (1)

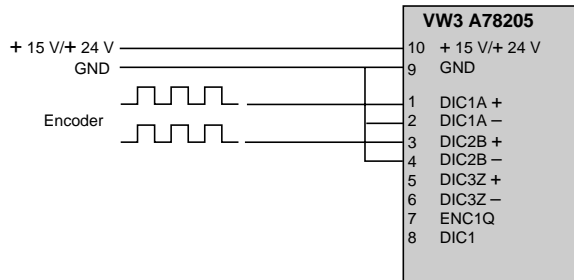

(1) If external supply is used, remember to connect the ground of external supply to terminal #9 of the VW3 A78205 and to the encoder ground.

#### One encoder to three VW3 A78207 option card

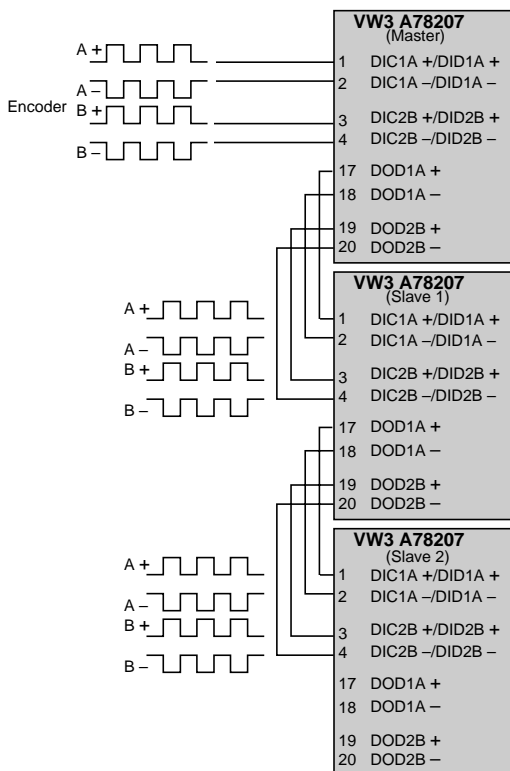

#### Two encoders to one VW3 A78207 option card

+ 15 V/+ 24 V from VW3 A78207 extension card

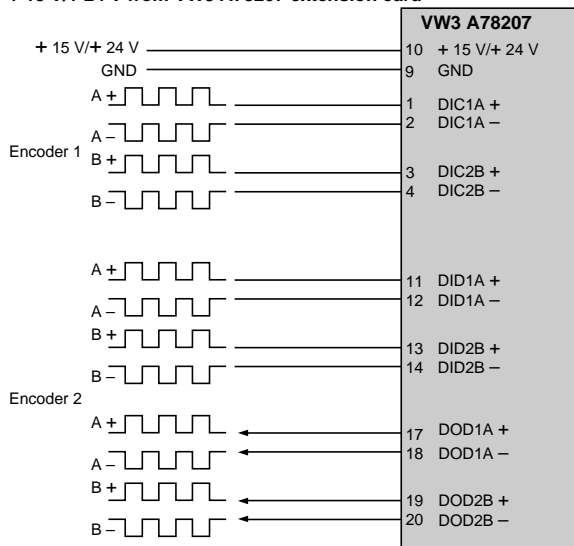

# Variable speed drives for asynchronous motors

Altivar 78  
Dialogue



## Presentation of the programming terminal

The Altivar 78 variable speed drive has a detachable programming terminal on the front panel which allows:

- Local control of the variable speed drive,
- Configuration of different parameters,
- Remote display and signalling of variable speed drive status, used in conjunction with a terminal support (see page 60629/2).

The programming terminal features an alphanumeric display with six indicators for variable speed drive status (RUN,  $\curvearrowright$ ,  $\curvearrowleft$ , STOP, READY, ALARM, FAULT) and three indicators for control (I/O Term, Keypad, Bus/comm). There are also three status indicators LEDs (ready, run, fault).

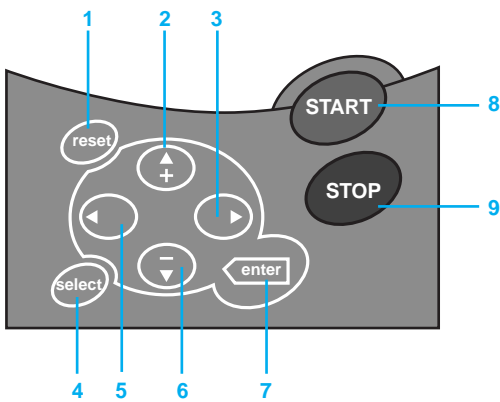

## Keypad pushbuttons

The alphanumeric control keypad features 9 pushbuttons that are used for the control of the variable speed drive (and motor), parameter setting and value monitoring.

- 1 This button is used to switch between the two most recent displays. This feature is useful when you want to see how the new value influences another value.
- 2 Edit values
- 3 Menu button right  
Move forward in menu  
Move cursor right (in parameter menu)  
Enter edit mode
- 4 This button is used to reset active faults
- 5 Menu button left  
Move backward in menu  
Move cursor left (in parameter menu)  
Exit edit mode  
Hold down for 2...3 seconds to return to main menu
- 6 Edit values
- 7 This button is used to confirm selections and to reset fault history (2 ...3 seconds).
- 8 Start button  
Pressing this button starts the motor if the keypad is in active control mode.
- 9 Stop button  
Pressing this button stops the motor (unless disabled by parameter R3.4/R3.6).



# Variable speed drives for asynchronous motors

Altivar 78  
Dialogue

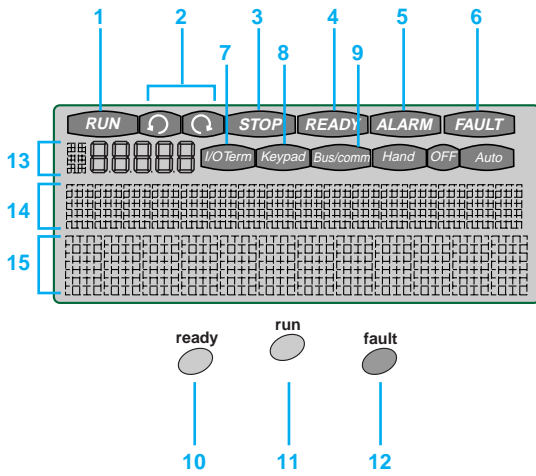

## Operator interface

- 1 RUN** Motor is running. Blinks when the stop command has been given but the frequency is still ramping down.
- 2**  Indicates the direction of motor rotation.
- 3 STOP** Indicates that the drive is not running.
- 4 READY** Lights when AC power is on. In case of a trip, the symbol will not light up.
- 5 ALARM** Indicates that the variable speed drive is running outside a certain limit and a warning is given.
- 6 FAULT** Indicates variable speed drive was stopped due to unsafe operating conditions.
- 7 I/O Term** START/STOP commands or reference values, etc. are given by the I/O terminals.
- 8 Keypad** The motor can be started or stopped, or its reference values, etc. altered from the keypad.
- 9 Bus/comm** The variable speed drive is controlled through a fieldbus.
- 10 ready** Illuminates with the AC power connected to the variable speed drive. Simultaneously, the status indicator READY is lit up.
- 11 run** Illuminates when the variable speed drive is running. Blinks when the STOP button has been pushed and the variable speed drive is ramping down.
- 12 fault** Illuminates when variable speed drive stops due to unsafe operating conditions. Simultaneously, the status indicator FAULT blinks on the display and the fault description can be seen.
- 13** Location indication: displays the symbol and number of menu, parameter etc.  
Example: M2 = Menu 2 (Parameters); P2.1.3 = Acceleration time
- 14** Description line: displays the description of menu, value or fault.
- 15** Value line: displays the numerical and textual values of references, parameters etc. and the number of submenus available in each menu.